

SUNBURST ECLIPSE AWNING

ROLL OUT PROCEDURE - ALL TERRAIN POSITION

We recommend the All Terrain position (when support arms remain attached to van) as it is stronger and more stable than Patio position.

1. Unlock both arms from travel position. To open travel locks squeeze rafter and top support arm together and move plastic slider upwards as far as possible See *Figure 1A*. Pull rod may be used to move slider in this step.
2. Loosen black rafter knobs located on back of both rafters. See *Figure 1B*.

Figure 1A



Figure 1B



3. Locate Ratchet Lever behind right end of roller. Using the pull down rod, move lever downward See *Figure 2*.

The ratchet mechanism is functioning correctly if a clicking noise is heard when rolling the awning out or in.

Figure 2

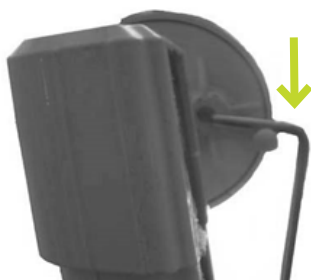

4. Insert pull rod through the loop in pull strap. Pull the awning open until fully extended. See *Figure 3A & 3B*. Do not overextend the roller.

Figure 3A



Figure 3B



5. Slide the rafter up support arm until it locks into position over the black spring button. Tighten knob on rafter to tension fabric. See *Figure 4*.
6. Repeat on other arm.

Figure 4



7. Raise the awning following the steps below:

- Swing trigger handle on the side of arm upward.
- Lift handle slightly and pull and hold the trigger with index finger.
- Using the handle, lift the awning half way up. Release the trigger and let arm slide down slowly until trigger locks.
- Repeat on other arm lifting awning all the way up
- Go back to the first arm and lift all the way up.



NOTE: In light rain conditions, lower one arm 300-600mm to allow water to drain from fabric to avoid water pooling. Not required if using Anti Flap Kits & Curved Roof Rafter's.



8. Install Curved Roof Rafters (optional)
- Fit hook end into the bracket underneath the awning track.
 - Extend rafter out and slot the spigot end into the hole in the roller tube.
 - Tighten the black locking knob.
- See separate CRR installation guide for more information.

MOVING FRAMESET LEGS FROM ALL TERRAIN POSITION TO PATIO POSITION

Ensure that any Anti-Flap Kit's and Curved Roof Rafters have been removed before attempting to move the frameset legs into the patio position.

- Set up the awning following the previous instructions for the Roll Out All Terrain Position.
 - Ensure rafter knobs shown in Figure 4 are very tight.
- IMPORTANT:** When the awning roller is parallel to the ground, move the ratchet lever to down (roll out) position.
- Depress latch on bottom bracket. Using the lift handle, swing arm away from van until set in vertical position. Do not pull trigger during this step.
 - Adjust roller to desired height using trigger handle and trigger.
 - Secure bottom foot to ground by driving stakes (not provided) in crisscross manner. Repeat on other arm. Take care not to break foot casting.

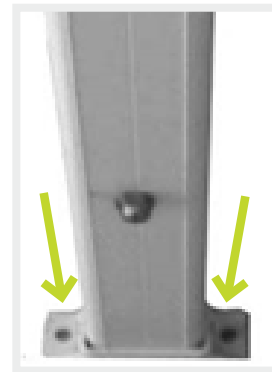

Additional tie down straps are recommended. We suggest either of the below:
 Caravan Awning Rope Clips - 05000020001000
 Tie Down Straps - 36000010001080

6. When erected ensure the roller pull strap sail track is positioned at 9 o'clock. See *Figure 5*. This will allow rain water to run off the fabric by minimising pooling behind the roller.

Reposition the roller as follows:

- a) Loosen black rafter knobs.
- b) Pull down and away from the vehicle to release pressure from the ratchet and move ratchet lever to the roll up position.
- c) Release the pressure on the pull strap and allow the roller to roll up until just past the 9 o'clock position. See *Figure 5*.
- d) Again, pull down and away on the pull strap.
- e) Check that the 9 o'clock position has been attained. If not repeat above process. This then locks the roller against the ratchet.
- f) Continue to pull down on the strap/bottom leg to maintain fabric tightness and tighten black rafter knob.
- g) Move to other end of awning, pull down on pull strap/bottom leg and tighten black rafter knob.

Figure 5 - 9 o'clock position (right hand end)

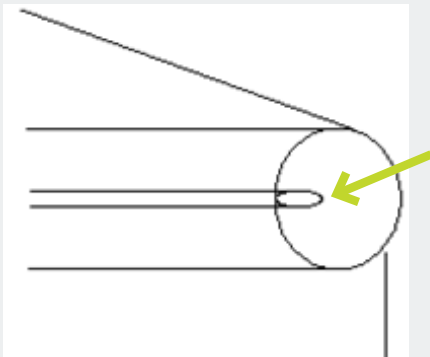

NOTE: By leaving the ratchet in the roll in position the awning will not be able to roll out under wind pressure, but is relying only on the black rafter knobs to stop it rolling in. To assist the black rafter knobs and to give added strength against wind flap and water pooling the addition of an Anti-Flap Kit and Curved Roof Rafters is recommended.

IMPORTANT NOTE FOR POP TOP CARAVANS:

As the awning rafter arm fits to the shoulder of the pop top caravan and not level with the fabric on the pop top, moving the arm back and forth from the All Terrain position to Patio position must be executed correctly. If not executed correctly the action has the potential to damage both the ratchet mechanism and the top frameset mounting bracket on the pop-top shoulder.

MOVING FRAMESET LEGS FROM PATIO POSITION BACK ONTO VEHICLE

1. Ensure that any Anti-Flap Kit's and Curved Roof Rafters have been removed before attempting to reposition the frameset legs.
2. Pull stakes from bottom foot. Release ropes.
3. Commencing with the rear arm (with ratchet mechanism) loosen the knurl knob on the arm. The ratchet should be in the roll out position.
4. Use lift handle (do not pull trigger) to swing arm back to bottom bracket. Push support arm firmly into bottom bracket until latch automatically secures foot on bottom support arm. See *Figure 6*.
5. Repeat procedure on other end of awning.

Figure 6

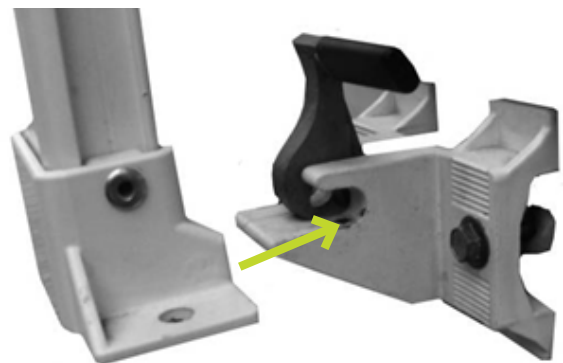

ROLL UP PROCEDURE

1. Lower both right and left support arms to the dome nut position using the lift handle and trigger. Lower one end 50% then the other fully and then the first one fully.
2. Loosen knob on rafter. Lower rafter by depressing lever on the outside of the frameset leg which will allow the slider to be released. Slide rafter to bottom of support arm. Repeat on other arm.



3. Slide pull strap to the right until ratchet lever is within reach.
4. Grasp pull strap, and by pulling out, release the pressure on the ratchet lever. Locate ratchet lever behind roller and rotate lever upwards and forward towards the front of the awning.

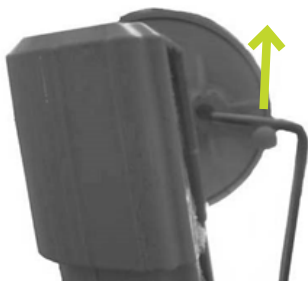

If ratchet lever is difficult to operate, use pull strap to rotate roller slightly as if to slacken fabric further. This reduces tension on mechanism and lever.

5. Slide pull strap more towards the centre of awning. Use pull strap to control speed of awning when rolling back towards R.V.

To avoid creating a bulge in awning fabric allow strap to roll up diagonally side by side across roller and fabric.

6. Lock both support arms in travel position. To lock squeeze rafter and top support arm together rotate travel locks behind rafters.
7. Tighten black knurl knobs. Ensure roller does not move when pull strap is given a slight tug. This confirms the ratchet mechanism is working correctly.



WARNING: The awning is under tension and can snap back against the vehicle. To avoid damage to awning or vehicle, **DO NOT** release ratchet lever without holding pull strap.

GENERAL MAINTENANCE

- Lubricate control handles, lock buttons, locking knobs, support arms and rafter sliders with silicone or similar lubricant to ensure easy operation.
- Check correct setting of adjustable stop bolts.
- Ensure all rivets and screws in brackets are tight.
- Keep your awnings clean. This is the best protection against mildew. Although the fabric is mildew resistant, mildew can still grow on accumulated dirt and eventually damage or stain the fabric.
- Wash down your awning. You can use a mild soap and water solution, or an approved vinyl cleaner, brushing lightly with a cloth or soft brush. Rinse thoroughly and allow drying prior to storage. We recommend doing this on a hot, sunny day.
- Keep the underside of your awning clean by simply brushing with a clean household broom. It may also be washed in the same manner as the top.

GENERAL TIPS

- In light rain conditions, lower one arm 300mm-600mm to allow water to drain from fabric and avoid water pooling.
- Accessories such as Aussie Traveller's Anti Flap Kit and Curved Roof Rafters will help eliminate wind flap and water pooling.
- When adding walls we recommend Aussie Traveller's Anti Flap Kit with built in wall attachment system.
- To avoid excessive force being exerted on ratchet mechanism do not remove support arm from bottom bracket until ratchet lever has been placed in down (roll out) position. Refer to label on support arm. Return ratchet lever to travel position when arm is replaced.

GENERAL TIPS

- If the ratchet mechanism is subjected to excessive force the ratchet lever may become over tensioned and difficult to operate. To relieve the tension:

In roll up position - Release right support arm from bottom bracket. Swing arm away from R.V. slightly until ratchet lever can be moved to open (roll out) position. Return support arm to bottom bracket.

In rolled out position - Rotate roller slightly, as if to slacken fabric. Reverse ratchet lever. When releasing lever maintain your grip on pull strap, to prevent awning from snapping back against van.

- Always close the awning in strong winds or rain.
- Damage to awning fabric, hardware and locking mechanism caused by wind, water pooling or extremely high/low temperatures is NOT covered by warranty. NEVER leave awning rolled out when unattended.

DO NOT....

- Do not operate awning in strong winds or rain.
- Do not allow awning to snap closed excessively hard.
- Do not remove support arm from bracket until ratchet lever has been placed in up (roll in) position. Refer to previous instructions.
- Do not overextend awning when rolling out.
- Do not fold or roll out in extreme cold temperatures.
- Do not get insect spray on the vinyl fabric, as some solutions may cause staining or discolour.
- Do not allow water to collect on awnings, causing water pooling.
- Do not overlook small rips or tears. Have them repaired or separation will result.
- Do not wash your awning with truck wash or a harsh strong solution, or with an abrasive cleaner.
- Do not BBQ, grill or have campfires underneath the awning.
- Do not store awnings when damp, or wet. Mildew may grow on the surface of a damp awning and permanently stain the fabric (If it is necessary to roll the awning away wet then roll out and dry at the first opportunity).
- Do not permit leaves, twigs, etc. to remain on your awning.
- Do not use a high pressure cleaning jet.