

**PROJECTA**

**12 VOLT**

# **SOLAR PANEL KITS**

**MONOCRYSTALLINE**

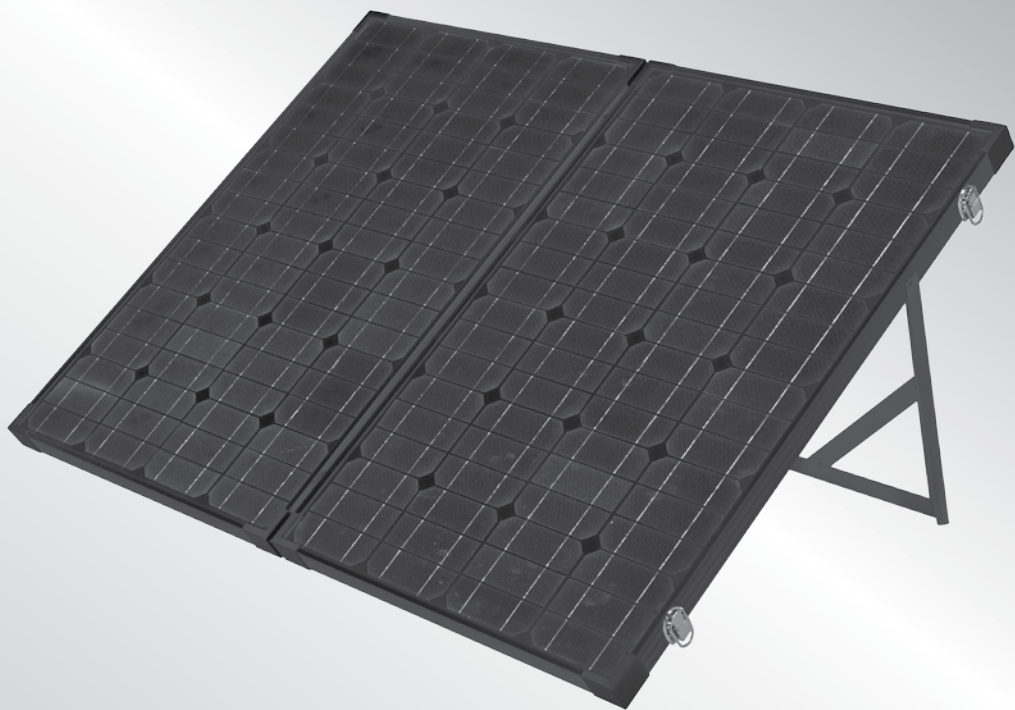

P/No. SPP120K

## **WARNING**

### **SOLAR PANEL**

- For installations with lead acid batteries, avoid sparks or flames near the batteries and always use proper eye protection
- Given sufficient light, solar panels always generate energy even when they are disconnected
- Accidental 'shorting' of the terminals or wiring can result in sparks causing personal injury or a fire hazard
- Do not scratch or bend solar panels
- Do not disassemble the solar panel
- When mounting solar panels at a height adhere to all relevant safety regulations
- Do not walk on modules
- Do not attempt to increase module output by concentrating light on its surface with mirrors
- Be sure to use components (cables, fuses, etc) greater than 25% of solar panel's maximum current ratings
- When storing the Solar panel kit do not pack heavy items on top the Solar panel bag
- Do not disassemble the controller. Take to a qualified person if the unit requires repairing

## **FEATURE OVERVIEW**

### **SOLAR PANEL**

**Compact and Powerful** – Monocrystalline solar panels are manufactured from a solar cell that is cast from silicon. These cells are more efficient at producing power than an amorphous panels, so the size of the panel is smaller yet produces greater output power.

**Heavy Duty Frame** – Corrosion resistant frames are constructed to withstand wind speeds in excess of 130 km/h in typical ground mounted applications. The frames are black anodized and the corner connection has a strong mechanical resistance to weather.

**Convenient Carry Bag** – This durable padded bag protects your solar panel during storage and transportation.

**Carry Handle & Safety Latches** – It is easy to carry the solar panels whilst out of the bag with the carry handle and using the safety latches to keep the solar panels closed shut.

**5 Meter Lead with Battery Clamps** – 5 meter battery leads are connected to the solar panels with battery clamps, so all you have to do is connect to the battery.

**Fold Away Support Legs** – The convenient support legs fold out from the rear to allow easy mounting on flat ground. The legs place the panels at an optimum angle for maximum performance.

## SPECIFICATIONS

P/No.	SPP120K
TYPE	MONOCRYSTALLINE
RATED POWER	120W
OPEN CIRCUIT VOLTAGE	21.0V
SHORT CIRCUIT CURRENT	7.5A
PEAK POWER VOLTAGE	18.0V
PEAK POWER CURRENT	6.87A
TEST CONDITIONS	1000W/m <sup>2</sup> , 25°C
BATTERY CONNECTIONS	Battery Clamps

## SOLAR CONTROLLER

**3 Stage Charging** – Built in regulator to prevent your battery from being overcharged. Overcharging occurs when the charge voltage is unregulated. This can result in premature battery failure.

The regulator also prevents your battery from being under charged, in the solar energy field, battery undercharge always occurs, especially on some Conventional lead – acid or Calcium batteries; The unit provides an automatic Equalization feature for deeply drained Conventional lead acid batteries or Calcium batteries.

It keeps the battery fully charged by using a process called “floating”. This means the controller will stop charging when the battery is full and will automatically start charging the battery as required. This process will also reduce water loss and help prevent the battery from ‘drying out’.

**Discharge Protection** – Protects your battery from discharge at night. Under low light or no light conditions the solar panel voltage could be less than the battery voltage. The unit contains a special circuit which prevents current flowing back from the battery and into the solar panel.

**LED Indicators** – Coloured LED’s to easily indicate the operational status and battery conditions.

**Unit Protection** – Multi charging protects against reverse polarity, short circuit, over temperature, over voltage, etc.

## CHARGING STAGES

**Bulk Charge (Level 1)** – Maximum current charging until batteries rise to Absorption level



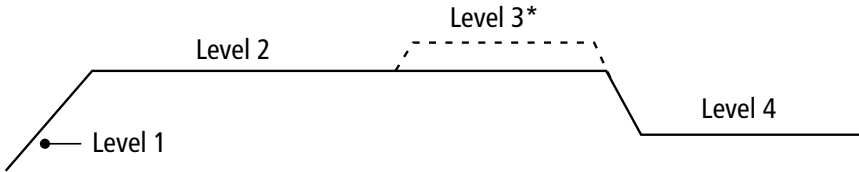

**Absorption Charge (Level 2)** – Constant voltage charging and battery is over 85%.

**Equalization Charge\* (Level 3)** – Only for WET battery or Calcium battery type, when the battery is deeply drained below 10V, it will automatically run this stage to bring the internal cells as an equal states and fully complement the loss of capacity.(Gel and AGM battery do not run Equalization charge)

**Float Charge (Level 4)** – Battery is fully charged and maintained at a safe level. A fully charged battery has a voltage of more than 13.6 Volts.



## LED OPERATION

	<p>Green ON when solar is charging battery Green blink when the system is over voltage</p>
	<p>Green ON when battery level in the right range Green slowly flashing when battery level full Yellow ON when battery level low Red ON when loads cut off</p>
	<p>Red slowly flashing when it is over load (the load amps is 1.25 times of rated current for 60 seconds, or the load amps is 1.5 times of rated current for 5 seconds) Red fast flashing when the load is short circuited</p>
	<p>Red ON when the switch is ON Red OFF when the switch is OFF</p>

## SOLAR CONTROLLER SPECIFICATIONS

TYPE	3 Stage Automatic
INPUT	12V Solar Panels
MAXIMUM INPUT	25V
BATTERY	12V
ABSORPTION	14.4V
EQUALISATION	14.8V (When voltage drops below 11.1V)
FLOAT	13.7V
START	9V
APPROVALS	EMC
BATTERY SIZES	250–1200CCA 300–1500MCA 40–200Ah

## INSTALLATION & CONNECTION

### STEP 1 Locate the panel in the best position

Locate the panel in a position where it is exposed to the sun for the majority of the day. For best results use a northern orientation. The panel will function in the horizontal or hung position, however for best performance tilt the panels so they directly face the sun.

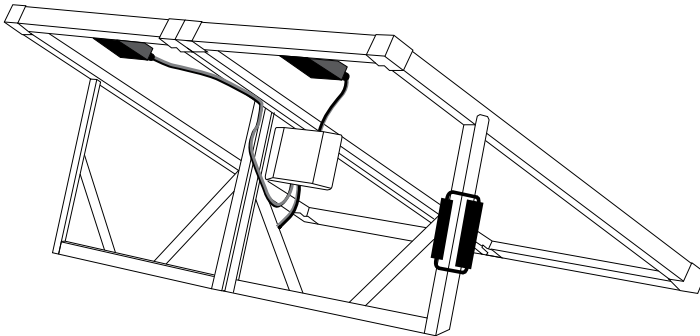

### STEP 2 Connect to the battery

Connect the 5 meter lead to the battery, Red clamp to the positive (+) terminal and Black clamp to the negative (-) terminal.

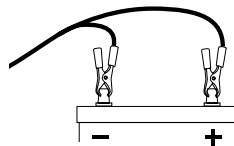

## MAINTENANCE

Periodically inspect the electrical and mechanical connections. Make sure they are all tight and free from corrosion. If necessary clean the surface of the solar panels with a soft damp cloth. Mild detergent can also be used. Any dirt or residue on the glass may effect performance.

## FREQUENTLY ASKED QUESTIONS

### Q. Can the solar panel be mounted on a flat roof or wall?

A. Yes. It is fine to mount the panel on a horizontal surface such as a roof or on a vertical surface like a wall as long as the panel receives full sun for a reasonable period of the day. You will however gain better performance if the panel is tilted toward the sun and faced in a northerly direction, since this enables the maximum amount of solar energy to reach the panel.

### Q. What current output can I expect?

A. The current output of the solar panel is based mostly on the available solar energy (sun rays). The current ratings given in the specifications table are based on the "ideal" sunlight conditions. In reality this may be achieved only on a very bright sunny day. The normal current output will therefore be a little lower. If the panel is shaded or if it is a very hot day the output will decrease further.

### Q. Will it charge my flat battery & how long will it take?

A. The SPP120K will charge a flat battery (above 9V) 250-1200CCA (Automotive) with a charge time of 8-35Hrs.

### Q. I am going on a 4WD trip, will 120 Watts be enough?

A. It really comes down to how many appliances are drawing power from your battery.

For example:

Most people when they go away would run a Fridge, and a couple of lights to cook with etc.

We need to work out how much power would be used in a day.

### Energy consumption per day

Appliance	Current use/hour (Ah)	Total time of use/day (Hours)	Total Current per day (Amps)
Fridge	1.5	24	36
3 Lights	3	3	9
<b>Grand Total</b>			<b>45</b>

If we say we get around 10 hours of solar energy from the panels per day (for summer months). We can then calculate what size and how many panels we need.

$45 \text{ amps} \div 10 \text{ hours} = 4.5 \text{ Amps per hour}$

So the SPP120K solar panel kit produce 7.5 Amps an hour, this should be more than enough.

You might find that during cloudy weather you will have to charge the battery by running your car for half an hour every second or third day.

**NOTES**

## **WARRANTY STATEMENT**

### **Applicable only to product sold in Australia**

Brown & Watson International Pty Ltd of 1500 Ferntree Gully Road, Knoxfield, Vic., telephone (03) 9730 6000, fax (03) 9730 6050, warrants that all products described in its current catalogue (save and except for all bulbs and lenses whether made of glass or some other substance) will under normal use and service be free of failures in material and workmanship for a period of one (1) year (unless this period has been extended as indicated elsewhere) from the date of the original purchase by the consumer as marked on the invoice. This warranty does not cover ordinary wear and tear, abuse, alteration of products or damage caused by the consumer.

To make a warranty claim the consumer must deliver the product at their cost to the original place of purchase or to any other place which may be nominated by either BWI or the retailer from where the product was bought in order that a warranty assessment may be performed. The consumer must also deliver the original invoice evidencing the date and place of purchase together with an explanation in writing as to the nature of the claim.

In the event that the claim is determined to be for a minor failure of the product then BWI reserves the right to repair or replace it at its discretion. In the event that a major failure is determined the consumer will be entitled to a replacement or a refund as well as compensation for any other reasonably foreseeable loss or damage.

This warranty is in addition to any other rights or remedies that the consumer may have under State or Federal legislation.

### **IMPORTANT NOTE**

Our goods come with guarantees that cannot be excluded under the Australian Consumer Law. You are entitled to a replacement or refund for a major failure and compensation for any other reasonably foreseeable loss or damage. You are also entitled to have the goods repaired or replaced if the goods fail to be of acceptable quality and the failure does not amount to a major failure.