

HYUNDAI
POWER PRODUCTS

DIESEL GENERATOR
DHY6000SE
DHY8000SE
DHY8000SELR

User Manual

CONTENTS

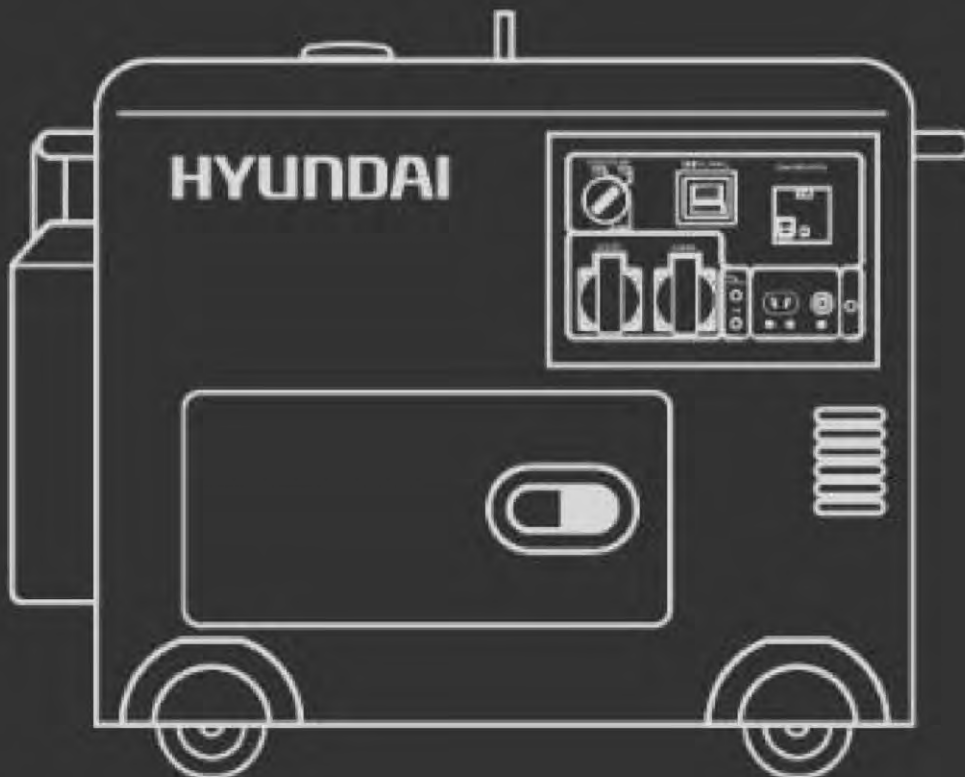







Section Description	Page No/No's
1. SAFETY	3 - 7
2. MACHINE LAYOUT	7 - 8
3. PREPARATION for STARTING	8 - 11
4. OPERATING THE GENERATOR	12 - 14
5. LOAD	14 - 15
6. STOPPING THE MACHINE	15
7. PERIODIC MAINTENANCE	16
8. LONG TERM STORAGE	17
9. TROUBLE SHOOTING	18
10. SPECIFICATIONS	19
11. WIRING DIAGRAM	20
12. SERVICE RECORD SHEET	21
13. GENPOWER CONTACT DETAILS	22
14. DECLARATIONS OF CONFORMITY	23

1. SAFETY

1.1. General safety notes.

- 1.1.1. The operator of the machine is responsible for, and has a duty of care in making sure that the machine is operated safely and in accordance with the instructions in this user manual. Keep the manual safe and pass it on if the machine is loaned or sold to another user.
- 1.1.2. Please note the following safety points.
 - 1.1.2.1. The machine should never be left in a condition which would allow an untrained or unauthorised person/s to operate this machine.
 - 1.1.2.1.1. All due care and diligence should be taken by the operator for the safety of, and with regard to, those around whilst using the machine.
 - 1.1.2.1.2. Some or all of the following - warning signs, symbols and/or PPE pictograms may appear throughout this manual. You MUST adhere to their warning/s. Failure to do so may result in personal injury to yourself or those around you.

The FOLLOWING safety notes will help avoid or reduce risk of injury or death.

 DANGER	 WARNING	 CAUTION
Indicates a hazard, which, if not avoided, could result in serious injury or death.	Indicates a hazard, which, if not avoided, could result in serious injury.	Indicates a hazard which, if not avoided, might result in minor or moderate injury.
 NOTE		
Indicates a situation that could easily result in equipment damage.	READ and keep the manual safe and pass it on if the machine is loaned or sold to another user.	You MUST fully read instructions to make sure you use and operate machine safely.

Appropriate Personal Protective Equipment (PPE)
MUST be worn at all times when machine is in use or being repaired.

 HAND PROTECTION MUST BE WORN	 EYE PROTECTION MUST BE WORN	 PROTECTIVE CLOTHING MUST BE WORN	 HEARING PROTECTION MUST BE WORN	 FOOT PROTECTION MUST BE WORN	 HEAD PROTECTION MUST BE WORN	 RESPIRATOR MUST BE WORN	 FACE SHIELD MUST BE WORN
---	--	---	--	---	--	--	---

ALWAYS keep the working area clear of non-essential people to include, but not limited to, children, the elderly and vulnerable persons.
NEVER ALLOW an untrained person to use this machine.

1.2. Carbon monoxide (where applicable).

- 1.2.1. Carbon monoxide is a colourless and odourless gas. Inhaling this gas can cause death as well as serious long term health problems such as braindamage.
- 1.2.2. The symptoms of carbon monoxide poisoning can include but are not limited to the following;

Headaches, dizziness, nausea, breathlessness, collapsing or loss of consciousness.

- 1.2.2.1. Carbon monoxide poisoning symptoms are similar to flu, food poisoning, viral infections and simply tiredness. It is quite common for people to mistake this very dangerous poisoning for something else.
- 1.2.2.2. To avoid carbon monoxide poisoning DO NOT use Petrol/Diesel-powered equipment inside any of the following;

Home, garage, tent, camper van, mobile home, caravan or boat.

This list is not exhaustive and if you are in any doubt contact your dealer.

- 1.2.3. If you think you have or someone around you has been affected by carbon monoxide poisoning;
 - 1.2.3.1. Get them fresh air immediately, by leaving the affected area or by opening doors and windows. If safe and practical to do so make sure that the machine is turned off. DO NOT enter a room you suspect of having carbon monoxide present – instead call the emergency services.
 - 1.2.3.2. Contact a doctor immediately or go to hospital - let them know that you suspect carbon monoxide poisoning.
- 1.2.4. **DO NOT** use in an enclosed area or a moving vehicle.

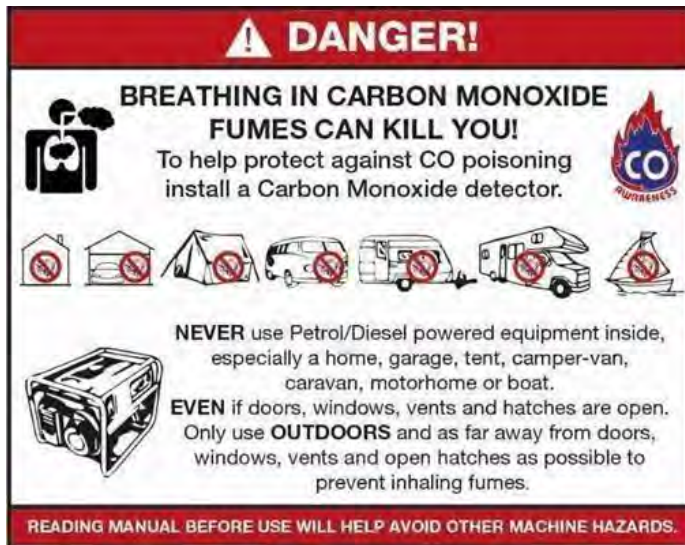

1.3. General fuel safety.



ALL FUELS ARE FLAMMABLE

- 1.3.1. Fire hazard - keep fuel away from all sources of ignition for example heaters, lamps, sparks from grinding or welding.



Fire Hazard

- 1.3.2. DO NOT carry out hot work on tanks that have contained fuel it is extremely dangerous.
 - 1.3.3. ALWAYS keep work area clean and tidy.
 - 1.3.4. ALWAYS clean up all spills promptly using correct methods i.e. absorbent granules and a lidded bin.
 - 1.3.5. ALWAYS dispose of waste fuels correctly.
- 1.4. Fueling/De-fueling (where applicable).



ALL FUELS ARE FLAMMABLE

- 1.4.1. ALWAYS fuel and defuel in a well-ventilated area outside of buildings.
- 1.4.2. ALWAYS wear correct, suitable and fit for purpose Personal Protective Equipment (PPE), suggested items are but not limited to safety gloves and overalls.



1.4.3. When fueling/de-fueling ALWAYS avoid inhaling fumes

1.4.4. When de-fueling ALWAYS use a proprietary fuel retriever.

1.4.5. ALWAYS carry fuel in the correct and clearly marked container.



Fire Hazard

1.5. Electrical safety.



Risk of electric shock

1.5.1. Electricity can kill - NEVER work on LIVE/ENERGISED equipment.

1.5.2. Prior to carrying out any maintenance work you MUST identify electrical isolation methods and isolate all electrical supplies,

1.5.3. Prior to use and with all electrical supplies isolated you MUST check all electrical cables, plugs and connections for the following;

1.4.1.1. Are intact and have no signs of damage, to include but not limited to bare wires, chaffing, cuts and loose wiring.

1.4.1.2. If there are any signs of damage, the damaged item MUST be taken out of service until the damage has been repaired by an electrically competent person.

1.4.1.3. All trailing cables should be routed so as not to cause any kind of trip hazard.

1.4.1.4. NEVER work on or near electricity with wet hands, wet clothing, and wet gloves.

1.6. Batteries



Corrosive

1.6.1. Batteries present a risk if they become damaged by the possible leaking of electrolyte. This electrolyte is an acid and can cause serious burn injuries. Care

should be taken when working on or near them. NOTE the electrolyte may be in liquid or gel form.

- 1.6.2. Should you come into contact with electrolyte you should;
 - 1.6.2.1. Remove all clothing contaminated with electrolyte. If you cannot remove then saturate in water.
 - 1.6.2.2. Get medical assistance as soon as possible. You must advise the medical staff of the type acid.
 - 1.4.1.4.1. Lead/acid battery = dilute sulphuric acid
 - 1.4.1.4.2. Nickel/cadmium = potassium hydroxide alkali electrolyte.
 - 1.6.2.3. Use fresh running water to wash off excess electrolyte, continue this until medical assistance arrives. Make sure that you do not wash the electrolyte to another part of the face or body.
 - 1.6.2.4. If electrolyte comes into contact with Eyes the electrolyte needs to be immediately washed away with large amounts of water. Make sure that you do not wash the electrolyte to another part of the face or body.
- 1.6.3. Gasses from charging batteries are highly flammable and great care should be taken to charge in well ventilated areas.
- 1.6.4. There is an explosion risk if the battery terminals are short circuited, when connecting/dis-connecting ALWAYS exercise great care so that the terminals or battery leads are NOT allowed to touch and cause a spark. ALWAYS use suitable insulated tools.



- 1.7. Vibrations (where applicable).
 - 1.7.1. Prolonged use of hand held (operated) machines will cause the user to feel the effects of/from vibrations. These vibrations can lead to white finger (Raynaud's phenomenon) or carpal tunnel syndrome. This condition reduces the ability of the hand to feel and regulate temperature, causing numbness and heat sensations and may cause nerve damage and circulatory tissue death.
 - 1.7.2. Not all factors that lead to white finger disease are known, but cold weather, smoking and other diseases that affect blood vessels and blood circulation as well as large and long-lasting impact of shocks are considered factors in the formation of white finger. Note the following to reduce the risk the white finger and carpal tunnel syndrome:
 - 1.7.2.1. Wear gloves and keep your hands warm
 - 1.7.2.2. Take regular breaks
 - 1.7.3. All of the above precautions may help reduce the risk of white finger disease but not rule out carpal tunnel syndrome. Long-term and regular users are therefore recommended to observe the condition of your hands and fingers. Seek medical attention immediately if any of the above symptoms should occur.

1.8. Noise.

- 1.8.1. The operating noise of the machine can damage your hearing. Wear hearing protection such as earplugs or ear defenders to protect your hearing. Long- term and regular users are advised to have hearing checked regularly. Be especially vigilant and cautious when wearing hearing protection because your ability to hear alarm warnings will be reduced.
- 1.8.2. Noise emissions for this equipment is unavoidable. Carry out noisy work at approved times and for certain periods. Limit the working time to a minimum. For your personal protection and protection of people working nearby it is also advisable for them to wear hearing protection.
- 1.8.3. See CERTIFICATE of CONFORMITY section for Outdoor Noise declaration of conformity.



1.4.7. Dispose of waste fuels correctly.

1.4.8. Diesel safety.  TOXIC FUMES

1.4.8.1. Always fuel and defuel in well-ventilated area.

1.4.8.2. Always wear correct, suitable and fit for purpose Personal Protective Equipment (PPE), suggested items are as follows, but are not limited too.



1.4.8.3. Hand protection.



1.4.8.4. Protective clothing.



1.4.8.5. Respiratory protective equipment should be used when in an unventilated area.

1.4.8.6. When defueling always use a propriety fuel retriever.

1.4.8.7. Always carry fuel in the correct and clearly marked container.

1.4.9. Petrol safety.  TOXIC FUMES

1.4.9.1. Always fuel and defuel in well-ventilated area.

1.4.9.2. Always wear correct, suitable and fit for purpose Personal Protective Equipment (PPE), suggested items are as follows, but are not limited too.



1.4.9.3. Hand protection.



1.4.9.4. Protective clothing.



1.4.9.5. Respiratory protective equipment should be used when in an unventilated area.

1.4.9.6. When defueling always use a propriety fuel retriever.

1.4.9.7. Always carry fuel in the correct and clearly marked container.

1.4.10. Electrical Safety.  SHOCK

1.4.10.1. Electricity can kill - never work on LIVE/ENERGISED equipment.

1.4.10.2. Identify electrical isolation method and always isolate all electrical supplies, prior to carrying out any maintenance work.

1.4.10.3. Prior to use and with all electrical supplies isolated check all electrical cables, plugs and connections for the following.

1.4.10.3.1. Are intact and have no signs of damage, to include but not limited to bare wires, chaffing, cuts and loose wiring. If there are any signs of damage, the damaged item should be taken out of service until the damage has been repaired by an electrically competent person.

1.4.10.4. All trailing cables should be routed so as not to cause any kind of trip hazard.

1.5. Additional Safety guidelines'

1.5.1. Exhaust and Engine

- 1.5.1.1. The engine and exhaust will become very hot during use do not touch.
- 1.5.1.2. These items remain hot for some time after use.
- 1.5.1.3. Place the machine in an area where pedestrians or children are not likely to touch themachine.
- 1.5.1.4. Avoid placing any flammable materials near the exhaust outlet during operation.
- 1.5.1.5. Keep the machine at least 1 m from buildings or other equipment, or the engine mayoverheat.
- 1.5.1.6. Avoid operating the engine with a dust cover.

1.5.2. Control Functions

1.5.2.1. Oil WarningSystem

- 1.5.2.1.1. When the pressure switch senses low oil pressure engine will stop automatically.
- 1.5.2.1.2. Unless you refill with oil the engine will not start again.

1.5.3. Starter Switch (SW)

- 1.5.3.1. The engine starter switch controls the ignition.
- 1.5.3.2. In the 'OFF' Position the ignition circuit is switched off and the enginewill not run
- 1.5.3.3. In the 'ON' position the engine is ready for starting
- 1.5.3.4. In the 'START' position (pushed against spring tension) the starter motor is engaged and the machine will start.



1.5.4. AC Switch (Breaker)

- 1.5.4.1. The AC Switch (Breaker) will turn 'OFF' automatically when the load exceeds the generator output.
- 1.5.4.2. If AC switch turns 'OFF' then before resetting remove some of the load and keep below the rated output of the machine.



- 1.5.5. DO NOT Connect the generator to Mains AC sockets in your building – commonly known as 'back feeding' it is extremely dangerous and illegal.

2. MACHINELAYOUT Typical control panel layout for Single phase machine.

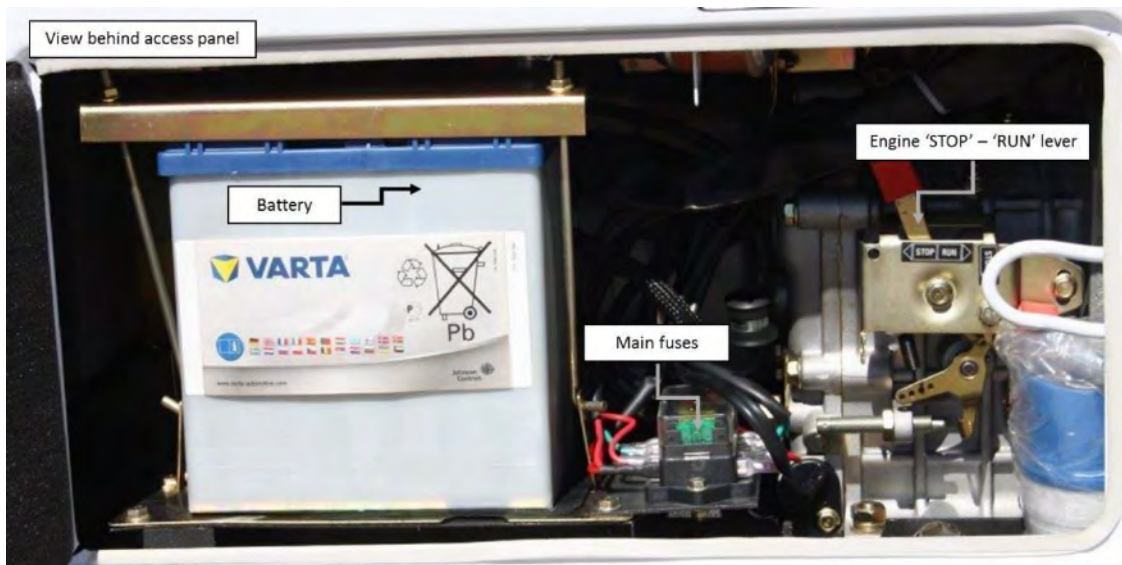
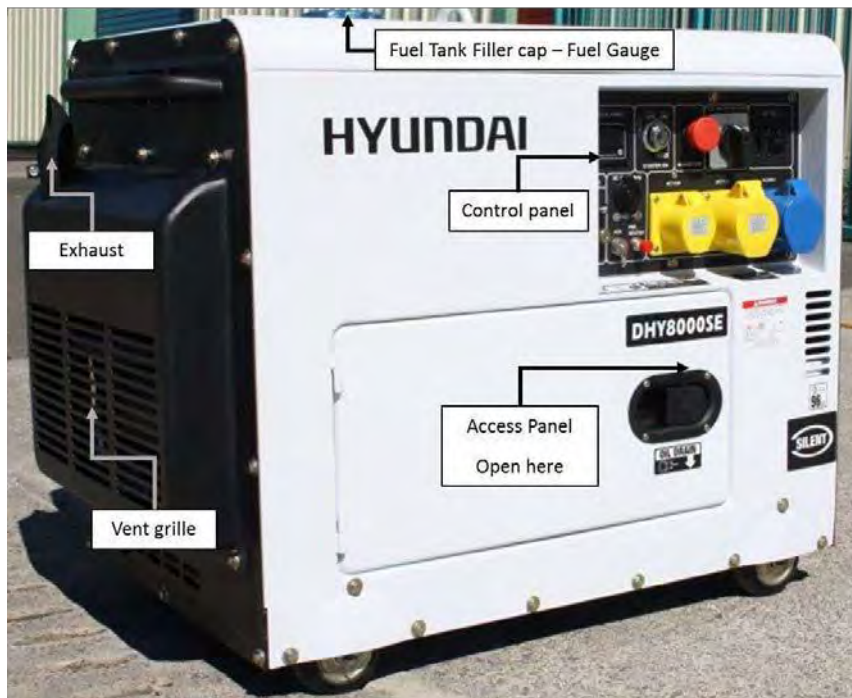





Typical control panel layout for Single & Three phase machine.



3. PREPARATION for STARTING

 WARNING	<input type="checkbox"/> DO NOT EXCEED INDIVIDUAL SOCKET AMP RATINGS.
--	--

-  **WARNING**
- DO NOT refill tank while engine is running or HOT.
 - Do not smoke or allow flames or sparks in the area where the engine is refueled or where the fuel is stored.
 - Do not overfill the diesel tank and make sure the filler cap is securely closed after refueling.
 - Take care not to spill fuel when refueling. If any fuel is spilled, make sure the area is clean and dry before starting the engine.

 **CAUTION** Wear suitable PPE, suggested but not limited too

3.1. Selection and handling of fuel.



3.1.1. Selection of fuel.

- 3.1.1.1. Only use standard specification diesel, this can be red or white.
- 3.1.1.2. Keep dust and water out of the fuel.
- 3.1.1.3. When filling the fuel tank from drums, make sure that no dust or water is mixed in with the fuel. This can cause serious damage to the fuel injection pump or the injector nozzle.
- 3.1.1.4. Do not overfill. Overfilling can potentially be very dangerous. Diesel can expand in hot weather and overflow
- 3.1.1.5. Always leave a 25mm gap above the fuel level.

! WARNING

□ Always check the engine oil level with the generator on a flat, level surface before starting or refilling the machine.

- If an insufficient amount of engine oil is used, damage to the engine may result.
- Do not overfill the engine with oil.
- This generator is equipped with a low oil pressure switch this system will stop the engine automatically when the oil pressure falls below the minimum pressure required.
- This helps prevent damage such as bearing seizures etc. However, this should not be relied upon and the engine oil level should be checked and topped up if required, daily.

! CAUTION

Wear suitable PPE, suggested but not limited to



3.2. Check and refill the engine oil.

3.2.1. To ensure the generator maintains an optimum performance and the life of the generator is as long as possible, it is important to use the correct engine oil – SAE10W/30 – SAE15W/40 (API CH-4/CF/SJ/SL diesel engine oil or higher grade) and change after the first 20 hours, then every 100 hours.

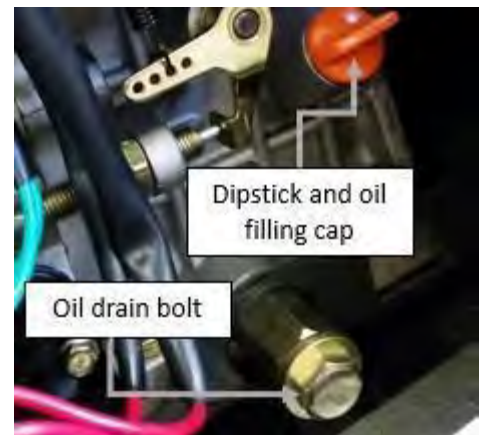

3.2.2. If the correct engine oil is not used, or the engine oil is not replaced every 100 hours, as required, the risk of crankshaft bearing failure, piston seizure, piston ring sticking and accelerated wear of the cylinder liner, main bearing and failure of other moving components increases significantly. The generator lifespan will be greatly reduced if oil level and oil changes are reduced.

3.2.3. Remove oil filler cap and check engine oil level

3.2.4. If oil level is below the lower level line, refill with SAE API CH-4/CF/SJ/SL diesel engine oil on dipstick, or to the top of filler neck. N.B. do not screw oil filler in the oil filler cap when checking oil level.

3.2.5. Change contaminated oil.

3.3. Service the AirCleaner.

! WARNING

- Do not wash air filter with detergent.
- Replace the air filter if the engine output decreases or excessive exhaust smoke is noticed.
- Never run the generator without the air filter, otherwise rapid engine wear will result.

- 3.3.1. Remove the access panel to reveal air filter cover.
- 3.3.2. Undo the nut (anti-clockwise) and remove the air cleaner cover and take out the element.
- 3.3.3. Clean the air filter.
- 3.3.4. Reattach the air filter cover and screw on the nut.

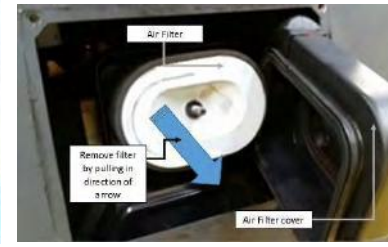
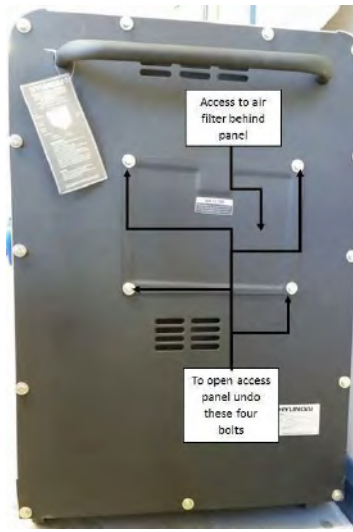

3.4. Checking the Generator before start up.

generator should be earthed to prevent electric shocks.

- Turn off the main breaker switch and remove all loads.

WARNING

- Be sure to turn off the main breaker switch before starting. The

CAUTION

- Before starting the engine, be sure to switch OFF any appliances connected to it.
- Ensure that the breaker switch is OFF before switching between 115v/230v.

3.5. Running-in periods of Operation.

- 3.5.1. The first 20 hours are the break-in period of the engine. For this reason, it is important to follow the following instructions during this period.
 - 3.5.1.1. Warm up the engine 5 minutes after the initial starting, before applying load.
 - 3.5.1.2. Avoid applying loads above 3kw during the first 20 hours of operation.
 - 3.5.1.3. It is important to replace the engine oil on time.
 - 3.5.1.4. Replace the engine oil whilst the engine is warm, after 20-hours running.
 - 3.5.1.5. Ensure that old engine oil is drained out completely.

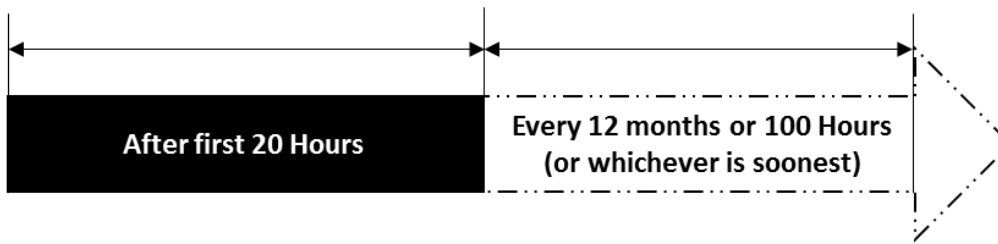

3.6. Battery.

 **WARNING**

- Do not connect tools or any other appliances to the generator before starting.

 **CAUTION**

- Explosive gases are given off when charging battery. Only charge in a well-ventilated area, away from sparks and naked flames.

3.6.1. Battery.

3.6.1.1. When you first install the battery, ensure that the battery's polarity is the same as the generator's battery leads - Black = negative, Red = positive.

3.6.1.2. Using a voltmeter - check the voltage is 12.3V+, if lower, the battery must be charged.

3.6.1.3. Check that the voltage is correct every month. The battery should be between 12.5v and 13.6v. When the engine is running it should re-charge the battery.

3.6.1.4. Make sure battery is free from damage and is not leaking. If battery shows signs of damage or leaking – DO NOT continue to use. Instead replace battery immediately.

3.6.1.5. Make sure that all battery acid spills are correctly cleaned up straight away.

3.6.1.6. The battery should be stored in a charged condition.

3.6.1.7. The battery is a 12 volt 36Ah sealed lead acid battery and requires no maintenance other than;

3.6.1.7.1. Ensure battery terminals are;

3.6.1.7.2. Kept clean.

3.6.1.7.3. Kept tight.

3.6.1.7.4. Covered to prevent shortcircuiting.

3.6.1.8. If the battery voltage is too low, it will require charging before use.

3.6.1.9. Keep the battery in a cool, dry place. It is important to clean the battery every three months and charge every six months.

4. OPERATING THE GENERATOR

 **CAUTION**

- Do not loosen or readjust either the engine speed limiting bolt or the fuel injection limiting bolt as this will cause the performance of the generator to be affected.



4.1. Starting.

- 4.1.1. Turn the main AC switch to the 'OFF' position.
- 4.1.2. Make sure that the machine has fuel for the task.
- 4.1.3 Make sure the emergency STOP switch is out (turn anti-clockwise).
- 4.1.4. Set the engine speed lever is set to 'RUN'.
- 4.1.5. Turn the starting key clockwise to the 'START' position.
- 4.1.6 Remove your hand from the key as soon as the engine starts.
- 4.1.7. If the engine does not start after 10 seconds, wait 15 seconds before trying again. Excessive start attempts will cause the battery to flatten.



- 4.1.8. If it does not start after 3 attempts, or runs intermittently with excessive smoke check that the fuel system is fully primed.

- 4.1.8.1. Priming - before starting to prime make sure that there is fuel in tank and that you can contain any fuel spill.

- 4.1.8.1.1. It is done by releasing the pipe clip on the diesel fuel line connected to the injector pump. Make sure you pinch the fuel line and then release slowly until all air is released and fuel appears.

- 4.1.8.1.2. When fuel appears replace pipe onto the injector pump and replace clip. Clear up any fuel spills before restarting.

- 4.1.8.1.3. The above may be necessary when new, or if the machine runs out of fuel.



Towel to collect spilt fuel



Injector pump inlet



No fuel



Fuel showing

- 4.1.9. Always leave the key in the 'ON' position whilst the engine is running.

- 4.1.10. Run machine for two minutes before applying load

- 4.1.11. Insert the plug into the socket you are about to use.

- 4.1.12. Turn the main AC switch to the 'ON' position and turn the electrical appliance 'ON'.

⚠ CAUTION

- If the engine has been running, the muffler will become very hot. Be careful not to touch the muffler until it has had time to fully cool down.
- Never refuel the fuel tank whilst the engine is still running.

4.2. Wireless remote controlled start (where fitted).

- 4.2.1. With the ignition switch in the OFF position, and the machine in all other aspects ready for operation (see usermanual).
- 4.2.2. The remote control has an approximate range of 25 metres in line of sight with no obstructions. This distance will reduce as the battery power depletes.
- 4.2.3. Pull back the protection shroud (4) to reveal the ON – OFF control buttons (1&3)
- 4.2.4. To start the machine press button (3) twice each time the tell-tale LED (Blue) will light. N.B. the first press arms system, second press starts machine.

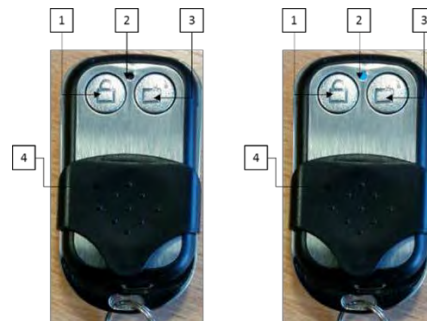

- 4.2.5. The machine will crank 3 times until started, if there is a NO start then a pause of 3 seconds,
- 4.2.6. The machine will crank 5 times until started, if there is a NO start then a pause of 3 seconds,
- 4.2.7. The machine will crank for 7 times until started, if there is NO start the machines wireless receiver will emit a ‘beeping sound’. You will now have to turn the machine OFF and back on to reset the wireless receiver.
- 4.2.8. The following are possible causes for a NO start,
 - 4.2.8.1. STOP/START lever in STOP position.
 - 4.2.8.2. Emergency STOP button activated.
 - 4.2.8.3. Low or no fuel.
 - 4.2.8.4. Flat battery.

4.3. Checks whilst generator is running.

- 4.3.1. After each use make sure that there are no abnormal sounds or vibration.
- 4.3.2. Check that the engine is running smoothly normally.
- 4.3.3. Check that there is no excessive smoke from the exhaust after 10 minutes of running, and the engine has reached working temperature
- 4.3.4. Check that there are no oil or fuel leaks.

NOTE

- fault.
- Please contact Genpower for assistance if any of the above, stop the engine and locate the required.

5. LOAD

CAUTION

- Start appliances one-by-one.

5.1. 230 Volt AC use.

5.1.1. After switching ON the main breaker switch, and the engine running check the Voltage reading when in 'Voltage Mode'. It should read 230v ± 5% (50Hz).

5.1.2. The Digital panel only becomes active when the Main breaker is in the 'ON' position. The following will be displayed by successive presses of the 'M' or mode button.

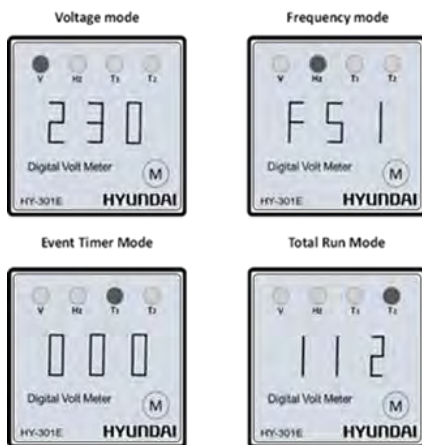

Lamp Illuminated	Indicating
V	Voltage
Hz	Frequency
V1	Event timer - or current running time (hours). This will reset to zero when main Breaker is 'OFF'
V2	Total Run Time

5.1.3. Connect the equipment to the generator in correct order.

5.1.4. Connecting the loads with the largest motor first, then the smaller items.

5.1.5. If the generator is overloaded the main breaker will trip.

5.1.6. To reset the breaker do the following;

5.1.6.1. Turn OFF and disconnect all loads.

5.1.6.2. Reset breaker, and add load onto the circuit to within 50% to 75% of rated output.

5.1.7. Wait a few minutes before resuming operation.

5.2. Electrical appliances, particularly motor driven equipment, will have a very high start-up current. The table below provides reference for connecting these appliances to the generator.

Type	Wattage		Example
------	---------	--	---------

	Starting	Rated	Typical appliance	Appliance	Starting	Rated
Lighting	x 1	x 1	Incandescent lamp or heating appliance	Incandescent lamp 1000 watts	100 vA	100 vA
Heating Appliance						
Fluorescent Lamp	x 2	x 1 to x 1.5	Fluorescent Lamp	Fluorescent Lamp	80 vA	40 to 60 vA
Motor Driven Equipment	x 3.5	x 1 to 2	Refrigerator, Electric fan, Compressor or grinder	Refrigerator 150 watts	450 to 750 vA	150 to 30 vA

6. STOPPING MACHINE

- Do not stop the engine suddenly or whilst under load.

WARNING ⚠ This can damage the AVR and cause damage to the alternator through overheating.

- Do not stop the engine with the decompression lever.

- 6.1. Switch OFF equipment connected to the generator.
- 6.2. Turn off the main breaker switch.
- 6.3. Run the generator without load for three minutes.
- 6.4. Turn the electric key start switch to the 'OFF' position.
- 6.5. Or press or pull down the stop lever.



7. PERIODIC MAINTENANCE

WARNING ⚠ Ensure the engine is off before performing any service.



- If the engine must be run, make sure that the area is well ventilated.
- The exhaust contains poisonous carbon monoxide gas.

- 7.1. Maintenance chart.

All work/s should be carried out by a competent person – if you need technical advice contact Genpower					
Item	Daily	First month or 20 hours	Every 100 hours / 12 months	Every 500 hours	Every year or 1000 hours
Check and refill with diesel	Yes				
Check and refill with engine oil	Yes				
Check for oil leakage	Yes				
Check and tighten fastening parts	Yes				
Check and tighten head bolts				Yes	

Replace engine oil		Yes First oil change	Yes		
Replace engine oil filter			Yes		
Replace air filter			Yes		
Replace fuel filter			Yes		
Check Fuel injection pump					Yes
Check injector nozzle					Yes
Check fuel pipes					Yes
Adjust clearance of intake and exhaust valves		Yes – First time			Yes
Grind intake/exhaust valves					Yes
Replace piston rings					Yes
Check battery condition			Yes		
Check carbon brushes and slip rings				Yes	

7.2. Replacing engine oil.



⚠ CAUTION After engine has been run prior to changing the oil will be very hot. Wear correct PPE minimum of   gloves and overalls.

⚠ CAUTION DO NOT allow any dust, dirt or any other debris enter oil or crankcase.

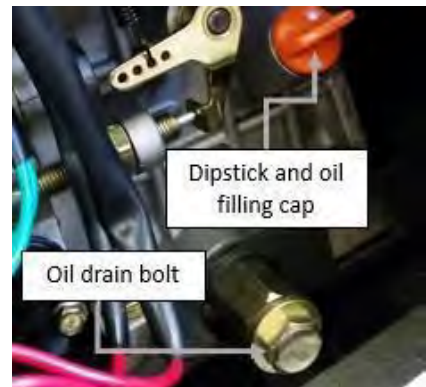
- 7.2.1. Remove the oil filler cap.
- 7.2.2. Remove the drain plug and drain the old oil while the engine is still warm.
- 7.2.3. The plug is located on the bottom of the cylinder block.
- 7.2.4. After draining, re-tighten the drain plug and refill with the recommended oil **API CH-4/CF/SJ/SL diesel engine oil or highergrade.**



8. LONG TERM STORAGE

⚠ WARNING After running the engine the oil will be very hot. Wear correct PPE minimum of gloves and overalls.  

- 8.1. If storing the generator for long periods of time, make the following operations.
 - 8.1.1. Operate the engine for 10 minutes and then stop.
 - 8.1.2. Stop the engine.
 - 8.1.3. Drain the engine oil whilst the engine is still warm and refill with fresh oil.

8.1.4. Turn the engine for 2-3 seconds with the decompression lever set at the non-compression position and the starting key set at the 'START' position. (Do not start the engine.)

8.1.5. Wipe off the oil and dirt from the engine and store in a dry place.

9. TROUBLESHOOTING.

9.1. Troubleshooting - N.B. all corrective actions should be carried out by suitably qualified person/s.

Problem	Possible fault/cause	Remedy
The Diesel engine will not start	The governer lever is not at START position	Set lever to START position
	Emergency STOP button activated(depressed)	Re-set emergency STOP button
	Insufficient fuel	Refill with fuel
	Fuel injection pump does not deliver fuel or delivers insufficient fuel	Remove the injector pump and have it tested
	Check the engine oil level	The specified oil level should be to the upper lever
	The injector has severe carbon build-up	Clean the injector
	The start motor turns slowly	Check battery performance and all connections
	The battery is flat	Charge or replace with a new one
The generator is not producing power	Main breaker switch has not been turned ON	Turn the main breaker to the ON position
	Alternator brushes worn	Replace the brushes
	The contact in the socket is not good	Make sure plugs are fully inserted into sockets
	The rated sped is too HIGH or too LOW	Adjust engine speed to produce 52 Hz with no load
	AVR is damaged	Replace AVR

10. SPECIFICATIONS

Model		DHY6000SE	DHY6000SELR	DHY8000SE	DHY8000SELR	DHY8000SELR-T	
		Single phase only				Single phase	Three phase
GENERATOR	Frequency Hz	50 Hz					
	Continuous Output Power kW	4.5 kW		5.5 kW		5.0 kW	6.3 kVA
	Max Power	5.2 kW		6.0 kW		5.5 kW	6.9 kVA

	Voltage AC Volts	115V/230V				230V	400V
	Sockets	16A + 32A @115V - 32A @230V				1 x 32A @ 230V	1 x 16A @ 400V
	Fuel Tank capacity	16	30	16	30	30	
	DC Output Volts - Amps	12V - 8.3A					
	Battery	12 v 36Ah					
ENGINE	Engine Type	Diesel					
	Engine	Hyundai D400, Forced Air-cooled, OHV			Hyundai D500E, Forced Air-cooled, OHV		
	Power Output HP	10 HP			12 HP		
	Start method	Electric					
	Displacement cc	418 cc			456 cc		
	Engine Speed rpm	3000 rpm					
	Lubrication Oil	SAE 10W/30 or 15W/40 (API CH-4/CF/SJ/SL diesel engine oil grade or higher)					
	Lubrication Oil Capacity (Litres)	1.75 Litres					
	Power Factor $\cos\phi$	1				1	0.8
	Voltage Regulation	Automatic Voltage Regulation - A.V.R.					
Weight dimension	Net Weight kg	152	156	154	160	156	
	Dimensions (L x W x H) mm	935 x 520 x 765	935 x 545 x 835	935 x 520 x 765	935 x 545 x 835	935 x 545 x 835	

D
11. WIRINGDIAGRAM

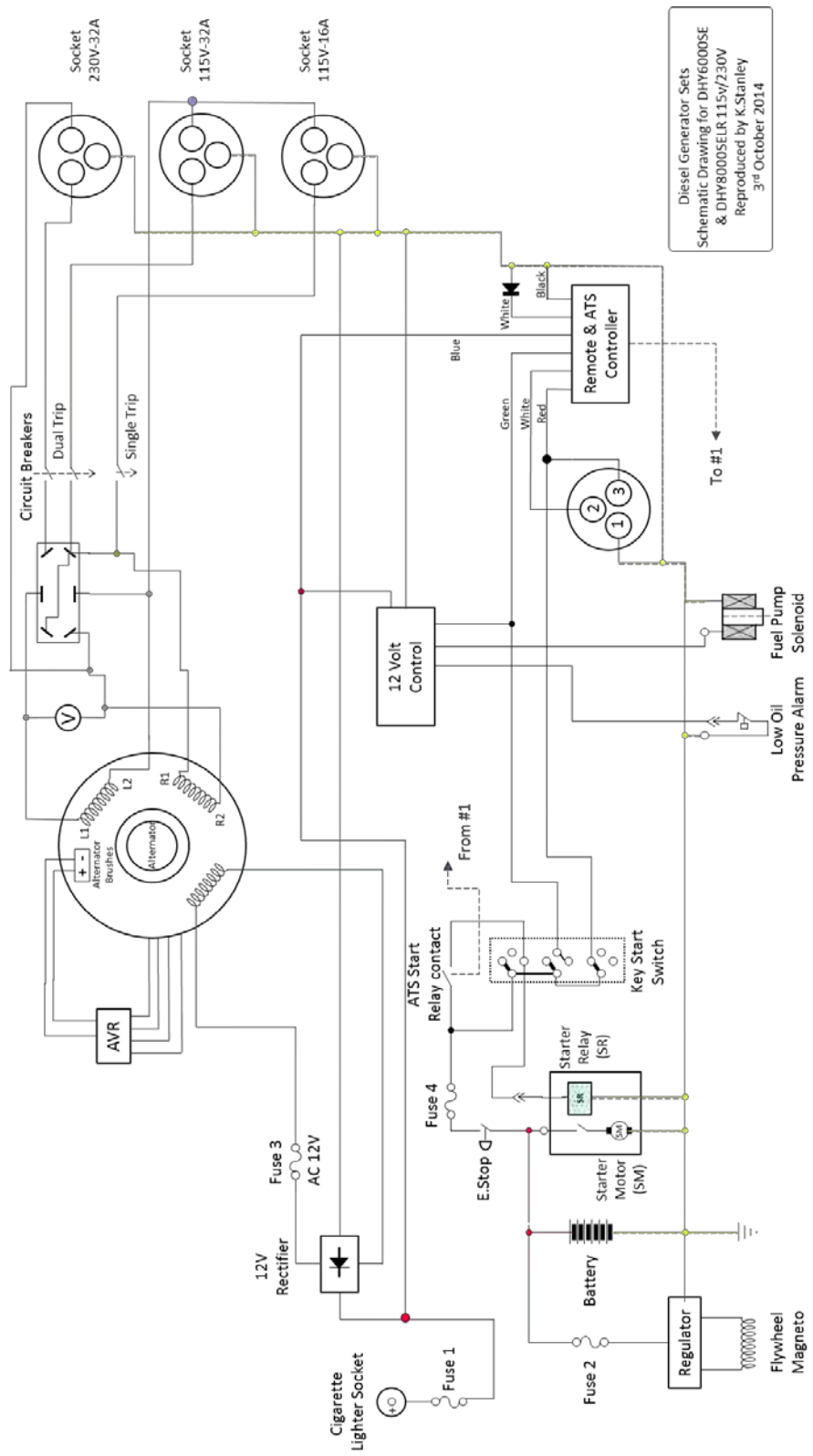

11.1. (N.B. Subject to change without prior notice).

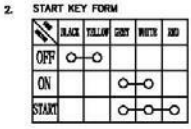
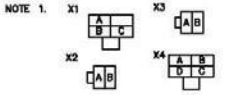
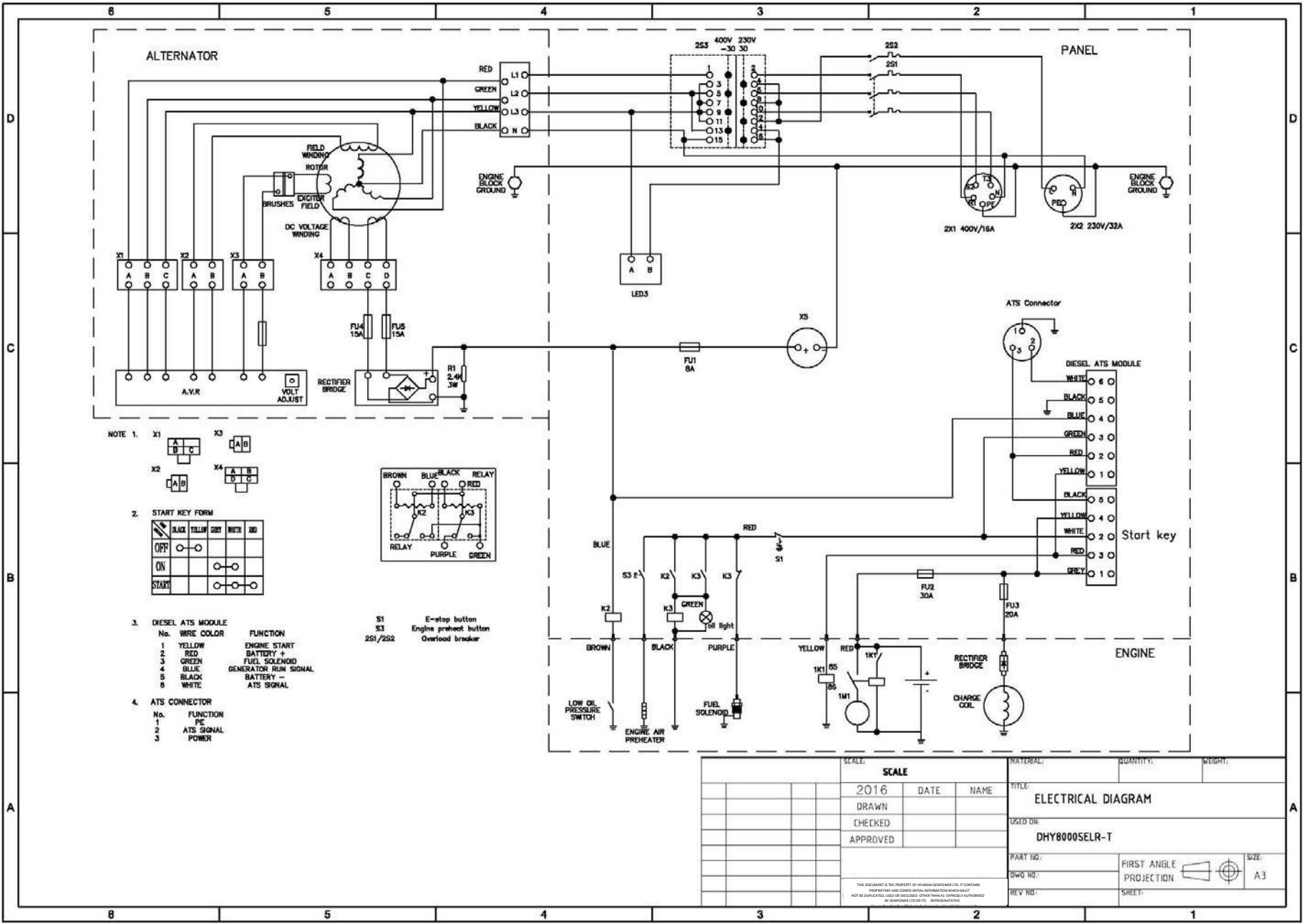

3. DIESEL ATS MODULE

No.	WIRE COLOR	FUNCTION
1	YELLOW	ENGINE START
2	RED	BATTERY +
3	GREEN	FUEL SOLENOID
4	BLUE	GENERATOR RUN SIGNAL
5	BLACK	BATTERY -
6	WHITE	ATS SIGNAL

4. ATS CONNECTOR

No.	FUNCTION
1	PE
2	ATS SIGNAL
3	POWER

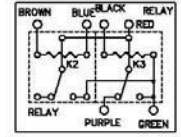

S1 E-stop button
S3 Engine preheat button
2S1/2S2 Overload breaker

SCALE		MATERIAL:	QUANTITY:	WEIGHT:
2016	DATE	TYPE: ELECTRICAL DIAGRAM		
DRAWN	NAME	USED ON: DHY8000SELR-T		
CHECKED		PART NO.:	FIRST ANGLE PROJECTION	SIZE: A3
APPROVED		DWG NO.:	SHEET:	
<small>THIS DOCUMENT IS THE PROPERTY OF HYUNDAI GENCO PVT. LTD. IT CONTAINS PROPRIETARY AND CONFIDENTIAL INFORMATION. IT IS NOT TO BE REPRODUCED, COPIED, OR DISCLOSED WITHOUT THE EXPRESS AUTHORIZATION OF HYUNDAI GENCO PVT. LTD.</small>				

- 13.3. FAX +44 (0) 1646 686198
- 13.4. TECHNICAL E-MAIL service@genpower.co.uk
- 13.5. WEBSITE www.hyundaipowerequipment.co.uk

14. MANUAL UPDATES

- 14.1. Our manuals are constantly being reviewed and updated. However if should you find an error, omission or something you find unclear please contact your dealer for assistance. E&OE.
- 14.2. Our latest manuals are also placed on line.
- 14.3. We reserve the right to make any modifications without prior notice whenever necessary.

15. DECLARATIONS OF CONFORMITY

- 15.1. Genpower Ltd confirms that these Hyundai products conform to the following CE Directives;
 - 2006/42/EC Machinery Directive.
 - 2004/108/EC EMC Directive.
 - 2000/14/EC Noise Emissions Directive .
 - 97/68/EC NRMM Emissions Directive.
 - 2006/95/EC Low Voltage Directive.

EC DECLARATION OF CONFORMITY

The undersigned, authorised by: **Genpower Ltd**

Declares that the following equipment manufactured under licence by Hyundai Corporation, Korea.
Conforms to the Directive: -

2000/14/EC (as amended)

Of the European Parliament and of the council on the approximation of the laws of the Member States relating to the noise emission in the environment by equipment for use outdoors.

Equipment Category:	Generator
Product Name/Model:	DHY6000SE(LR) – DHY8000SELR – DHY8000SELR-T
Type/Serial No:	Silenced diesel generator
Electric Power	DHY6000SE(LR) - 5.2 kW
	DHY8000SELR- DHY8000SELR-T - 6.0 kW

The technical documentation is kept by: **Roland Llewellyn,**
Genpower Ltd, Isaac Way, London Road, Pembroke Dock, SA72 4RW, Pembrokeshire, SA73 2RS, United Kingdom.

The conformity assessment procedure followed was in accordance with annex VI of the Directive.

Notified Body: **European Certifying Organisation**
Via Mengolina, 33, Faenze, 48018,
Italy
Certification N° N714F09351011

Measured Sound Power Level: **96dB(A)**

Guaranteed Sound Power Level: **96dB(A)**

A copy of this certificate has been submitted to the European Commission and to EU Member State United Kingdom.

Place of Declaration: **Pembroke Dock**

Date: **28/06/2013**

Signed by: **Roland Llewellyn**

Position in Company: **Director**

Name and address of manufacturer or Authorised representative:

Roland Llewellyn,

Genpower Ltd, Isaac Way, London Road,

Pembroke Dock, SA72 4RW, Pembrokeshire, SA72 4RW, United Kingdom.

16. RECYCLING & PRODUCT DISPOSAL

16.1. We do not offer a takeback scheme for the recovery of Waste Electrical Electronic Equipment (WEEE) & Batteries instead the responsibility to dispose of WEEE and or Batteries is passed onto you by us. So when it becomes necessary to dispose of your machine you must take it to your local Civic Amenity Site. For further information please contact your Local Authority for disposal advice.

16.2. You MUST make sure that all unused oil and fuel is disposed of correctly either beforehand or at your local Civic Amenity Site. Under NO circumstance must any oil and fuel be put down any drains.

16.3. Waste Electrical Electronic Equipment (WEEE) recycling.

16.3.1. Certain products contain WEEE waste which should not be disposed of in your domestic waste.



16.3.2. You MUST recycle WEEE in accordance with your local authority or recycling centre.

16.4. Battery recycling, certain products contain batteries which should not be disposed of in your domestic waste.



16.4.1. You MUST recycle batteries in accordance with your local authority or recycling centre.

16.5. Unwanted packaging materials should be sorted and taken to a recycling centre so it can be disposed of in a manner which is compatible with the environment.

16.6. The following symbol means that you should 'Reduce – Reuse – Recycle'.



16.7. We are a Member of the VALPAK National Compliance scheme and our registration number is **RM08660**

16.8. For further information about disposal please contact your Local Authority.

16.9. You can also get more advice and guidance about recycling at the following website <http://www.recycle-more.co.uk>

16.10. Should you pass this product onto another user either sold or loaned you MUST pass on this user manual. This will make sure that all other users can use and maintain the machine safely.



NOTES

HYUNDAI
POWER PRODUCTS

For Inquiries, Please Contact:

GENPOWER LTD
Isaac Way, London Road
Pembroke Dock, UNITED KINGDOM, SA72 4RW
T: +44 (0) 1646 687 880 F: +44 (0) 1646 686 198
E: info@hyundaipowerequipment.co.uk
www.hyundaipowerequipment.co.uk