

GE 4500 HSX

0704

354559003 - GB

ENGLISH



UNI EN ISO 9001 : 2000

MOSA has certified its quality system according to UNI EN ISO 9001:2000 to ensure a constant, high quality of its products. This certification covers the design, production and servicing of engine driven welders and generating sets.

The certifying institute, ICIM, which is a member of the International Certification Network IQNet, awarded the official approval to MOSA after an examination of its operations at the head office and plant in Cusago (MI), Italy.

This certification is not a point of arrival but a pledge on the part of the entire company to maintain a level of quality of both its products and services which will continue to satisfy the needs of its clients, as well as to improve the transparency and the communications regarding all the company's activities in accordance with the official procedures and in harmony with the MOSA Manual of Quality.

The advantages for MOSA clients are:

- Constant quality of products and services at the high level which the client expects;
- Continuous efforts to improve the products and their performance at competitive conditions;
- Competent support in the solution of problems;
- Information and training in the correct application and use of the products to assure the security of the operator and protect the environment;
- Regular inspections by ICIM to confirm that the requirements of the company's quality system and ISO 9001 are being respected.

All these advantages are guaranteed by the CERTIFICATE OF QUALITY SYSTEM No.0192/3 issued by ICIM S.p.A. - Milano (Italy) - www.icim.it

M 1.01	COPYRIGHT
M 1.1	NOTES
M 1.4	NOTES
M 2	SYMBOLS USED AND SAFETY PRECAUTIONS
M 2.3 -....	ABBREVIATIONS AND SYMBOLS
M 2.5 -....	INSTALLATION AND WARNINGS PRIOR TO OPERATION
M 2.6	INSTALLATION WARNINGS
M 2.7	INSTALLATION
M 3	PACKING
M 4.1	TRANSPORT AND HANDLING
M 25....	SET-UP FOR OPERATION
M 26	START-UP
M 27	SHUTTING DOWN THE MOTOR
M 31	CONTROLS
M 37...	USING THE GENERATOR
M 38.5	REMOTE CONTROL
M 40.2...	TROUBLE SHOOTING
M 43...	MACHINE MAINTENANCE
M 44.5	MAINTENANCE ON THE POWER UNIT WITH AUTOMATIC PANELS
M 45	STORAGE
M 46	DEMOLITION
M 51	TECHNICAL SPECIFICATIONS
M 53	DIMENSIONS
M 60	ELECTRICAL SYSTEM LEGEND
M 61-.....	ELECTRICAL SYSTEM
R 1	SPARE PARTS TABLES
GA ...	SPARE PARTS

⚠ ATTENTION

This use and maintenance manual is an important part of the machines in question.

The assistance and maintenance personnel must keep said manual at disposal, as well as that for the engine and alternator (if the machine is synchronous) and all other documentation about the machine.

We advise you to pay attention to the pages concerning the security (see page M1.1).

MOSA

© All rights are reserved to said Company.

It is a property logo of MOSA division of B.C.S. S.p.A. All other possible logos contained in the documentation are registered by the respective owners.

➡ The reproduction and total or partial use, in any form and/or with any means, of the documentation is allowed to nobody without a written permission by MOSA division of B.C.S. S.p.A.

To this aim is reminded the protection of the author's right and the rights connected to the creation and design for communication, as provided by the laws in force in the matter.

In no case MOSA division of B.C.S. S.p.A. will be held responsible for any damage, direct or indirect, in relation with the use of the given information.

MOSA division of B.C.S. S.p.A. does not take any responsibility about the shown information on firms or individuals, but keeps the right to refuse services or information publication which it judges discutible, unright or illegal.

INFORMATION

Dear Customer,
We wish to thank you for having bought from MOSA a high quality set.

Our sections for Technical Service and Spare Parts will work at best to help you if it were necessary.

To this purpose we advise you, for all control and overhaul operations, to turn to the nearest authorized Service Centre, where you will obtain a prompt and specialized intervention.

☞ In case you do not profit on these Services and some parts are replaced, please ask and be sure that are used exclusively original MOSA parts; this to guarantee that the performances and the initial safety prescribed by the norms in force are re-established.

☞ *The use of **non original spare parts will cancel immediately any guarantee and Technical Service obligation from MOSA.***

NOTES ABOUT THE MANUAL

Before actioning the machine please read this manual attentively. Follow the instructions contained in it, in this way you will avoid inconveniences due to negligence, mistakes or incorrect maintenance. The manual is for qualified personnel, who knows the rules: about safety and health, installation and use of sets movable as well as fixed.

You must remember that, in case you have difficulties for use or installation or others, our Technical Service is always at your disposal for explanations or interventions.

The manual for Use Maintenance and Spare Parts is an integrant part of the product. It must be kept with care during all the life of the product.

In case the machine and/or the set should be yielded to another user, this manual must also given to him.

Do not damage it, do not take parts away, do not tear pages and keep it in places protected from dampness and heat.

You must take into account that some figures contained in it want only to identify the described parts and therefore might not correspond to the machine in your possession.

INFORMATION OF GENERAL TYPE

In the envelope given together with the machine and/or set you will find: the manual for Use Maintenance and Spare Parts, the manual for use of the engine and the tools (if included in the equipment), the guarantee (in the countries where it is prescribed by law).

Our products have been designed for the use of generation for welding, electric and hydraulic system; ANY OTHER DIFFERENT USE NOT INCLUDED IN THE ONE INDICATED, relieves MOSA from the risks which could happen or, anyway, from that which was agreed when selling the machine; MOSA excludes any responsibility for damages to the machine, to the things or to persons in this case.

Our products are made in conformity with the safety norms in force, for which it is advisable to use all these devices or information so that the use does not bring damage to persons or things.

While working it is advisable to keep to the personal safety norms in force in the countries to which the product is destined (clothing, work tools, etc.).

Do not modify for any motive parts of the machine (fastenings, holes, electric or mechanical devices, others..) if not duly authorized in writing by MOSA: the responsibility coming from any potential intervention will fall on the executioner as in fact he becomes maker of the machine.







☞ **Notice:** *this manual does not engage MOSA, who keeps the faculty, apart the essential characteristics of the model here described and illustrated, to bring betterments and modifications to parts and accessories, without putting this manual uptodate immediately.*



MOSA**CE MARK**

© MOSA 1.2-06/03

GE_, MS_, TS_, EAS_**M
1.4**

Tel.: 02 - 90352.1 Fax: 02 - 90390466 e-mail : info@mosa.it www.mosa.it	 Divisione della BCS S.p.A. V.le Europa 59 - 20090 Cusago (Mi) - Italia	   ISO 9001:2000 - Cert. 0192/3
DICHIARAZIONE DI CONFORMITA'  Déclaration de Conformité – Declaration of Conformity – Konformitätserklärung Conformiteitsverklaring – Declaración de Conformidad		
MOSA dichiara sotto la propria responsabilità che la macchina: MOSA déclare, sous sa propre responsabilité, que la machine: MOSA declares, under its own responsibility, that the machine: MOSA erklärt, daß die Aggregate: MOSA verklaard, onder haar eigen verantwoordelijkheid, dat de machine: MOSA declara bajo su responsabilidad que la máquina:		
Modello/Modèle/Model/Modell/Model/Modelo: _____ Codice/ Code/ Code/ Kode/ Code/ Código: _____		
è conforme con quanto previsto dalle Direttive Comunitarie e relative modifiche: est en conformité avec ce qui est prévu par les Directives Communautaires et relatives modifications: conforms with the Community Directives and related modifications: mit den Vorschriften der Gemeinschaft und deren Ergänzungen übereinstimmt: in overeenkomst is met de inhoud van gemeenschapsrichtlijnenen gerelateerde modificaties: cumple con los requisitos de la Directiva Comunitaria y sus anexos:		
98/37/CE - 73/23/CE - 89/336/CE - 2000/14/CE		
per la verifica sono state considerate le seguenti norme armonizzate, Norme nazionali e internazionali: pour la vérification de la conformité ont été consultées les normes harmonisées suivantes, normes nationales et internationales: to check the conformity, the following harmonized norms, national and international norms, have been consulted: zur Prüfung hat man die folgenden übereinstimmenden nationalen und internationalen Normen herangezogen: ter verificatie van de overeenkomst, zijn de volgende geharmoniseerde normen, nationaal en internationaal, geconsultoord: para su verificación se han tenido en cuenta las Normas armonizadas, Normas nacionales e Internacionales:		
Norme armonizzate - normes harmonisées - harmonized norms - übereinstimmende Normen geharmoniseerde normen - Normas armonizadas: EN 292-1 EN 292-2 EN 60204-1 EN 50199 EN 60974-1 (Solo per modelli - Seulement pour les modèles - Only for models - nur für die Modelle - Alleen voor de modellen - Sólo para modelos: TS) EN 50081-2 EN 50082-2		
Altre norme - autres normes - other norms - andere Normen - andere normen - otras normas: ISO 8528 (Solo per modelli - Seulement pour les modèles - Only for models - nur für die Modelle - Alleen voor de modellen - Sólo para modelos: GE)		
 Ing. Benso Marelli Direttore Generale		Cusago, _____

MM 065.2.doc

CE The CE mark (European Community) certifies that the product complies with the essential safety requirements provided by the applicable COMMUNITY DIRECTIVES. In the Conformity Declaration are reported the HARMONIZED NORMS and not, used for the checking.

SYMBOLS IN THIS MANUAL

- The symbols used in this manual are designed to call your attention to important aspects of the operation of the machine as well as potential hazards and dangers for persons and things.

IMPORTANT ADVICE

- Advice to the User about the safety:

☞ N.B.: The information contained in the manual can be changed without notice. Potential damages caused in relation to the use of these instructions will not be considered because these are only indicative. Remember that the non observance of the indications reported by us might cause damage to persons or things. It is understood, that local dispositions and/or laws must be respected.

WARNING



Situations of danger - no harm to persons or things

Do not use without protective devices provided

Removing or disabling protective devices on the machine is prohibited.

Do not use the machine if it is not in good technical condition

The machine must be in good working order before being used. Defects, especially those which regard the safety of the machine, must be repaired before using the machine.

SAFETY PRECAUTIONS



DANGEROUS

This heading warns of an immediate danger for persons as well for things. Not following the advice can result in serious injury or death.



WARNING

This heading warns of situations which could result in injury for persons or damage to things.



CAUTION

To this advice can appear a danger for persons as well as for things, for which can appear situations bringing material damage to things.



IMPORTANT



NOTE



ATTENTION

These headings refer to information which will assist you in the correct use of the machine and/or accessories.

SYMBOLS (for all MOSA models)



STOP - Read absolutely and be duly attentive



Read and pay due attention



GENERAL ADVICE - If the advice is not respected damage can happen to persons or things.



HIGH VOLTAGE - Attention High Voltage. There can be parts in voltage, dangerous to touch. The non observance of the advice implies life danger.



FIRE - Danger of flame or fire. If the advice is not respected fires can happen.



HEAT - Hot surfaces. If the advice is not respected burns or damage to things can be caused.



EXPLOSION - Explosive material or danger of explosion. in general. If the advice is not respected there can be explosions.



WATER - Danger of shortcircuit. If the advice is not respected fires or damage to persons can be caused.



SMOKING - The cigarette can cause fire or explosion. If the advice is not respected fires or explosions can be caused.



ACIDS - Danger of corrosion. If the advice is not respected the acids can cause corrosions with damage to persons or things.



WRENCH - Use of the tools. If the advice is not respected damage can be caused to things and even to persons.



PRESSION - Danger of burns caused by the expulsion of hot liquids under pressure.



ACCES FORBIDDEN to non authorized people.

PROHIBITIONS No harm for persons

Use only with safety clothing -



It is compulsory to use the personal protection means given in equipment.

Use only with safety clothing -



It is compulsory to use the personal protection means given in equipment.

Use only with safety protections -



It is a must to use protection means suitable for the different welding works.

Use with only safety material -



It is prohibited to use water to quench fires on the electric machines.

Use only with non inserted voltage -



It is prohibited to make interventions before having disinserted the voltage.

No smoking -



It is prohibited to smoke while filling the tank with fuel.

No welding -



It is forbidden to weld in rooms containing explosive gases.

ADVICE No harm for persons and things

Use only with safety tools, adapted to the specific use -

It is advisable to use tools adapted to the various maintenance works.

Use only with safety protections, specifically suitable



It is advisable to use protections suitable for the different welding works.

Use only with safety protections -



It is advisable to use protections suitable for the different daily checking works.

Use only with safety protections -











It is advisable to use all protections while shifting the machine.

Use only with safety protections -









































































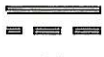

It is advisable to use protections suitable for the different daily checking works and/or of maintenance.

<p>°C: temperature Celsius grades 10: 10 kVA synchronous (wording example) 10000: 10 kVA asynchronous (wording example) A: Ampere A: ADIM engine atm: pressure B: pretrol BAT: battery BC: base current C.A.(c.a.): alternating current C.B.: battery charger C.C.(c.c.): direct current cc: cm³ (volume) CE: European norm conformity CF: special for pipe welding CTL: slow touring trolley CTM CTV: fast touring trolley: hand touring trolley D: diesel D: GFI D: Deutz engine E: electric start EAS: automatic intervention panel for generating sets for connection to the mains EL: electronic regulation, allows to use welder and generating set simultaneously EP1: automatic accelerator according to requested power, engine protection, low oil pressure, high temperature with engine stop, trouble warning lights EP2: engine protection, low oil pressure, high temperature with engine stop, trouble warning lights EP4: engine protection, low oil pressure, high temperature with engine stop, no battery charge, belt broken, low fuel level with engine stop, trouble warning lights EP5: engine protection, low oil pressure, high temperature with engine stop, no battery charge, belt broken, low fuel level with engine stop, overspeed, trouble warning lights ES: oil/temperature engine protection device EV: electrovalve g/kwh: grams/kilowatt hour (engine consumption) GA: asynchronous alternator GE: generating set GHF: high frequency alternator GS: synchronous alternator h: hour meter (symbol) H: Hatz engine H: Honda engine HI: hydraulic central Hz: frequency I: single-phase auxiliary generation (symbol 1~) IP: protection grade for electric devices against access to dangerous parts according to the IEC 529 norm (Internal Protection) kg: kilogram (mass) K: welding cables set kVA: kilovolt ampere kW: kilowatt (engine power) kWh: kilowatt hour (energy) l: liters (capacity)</p>	<p>L: Lombardini engine Lwa: maximum acoustic (power level) according to EEC norm 535/536 mm: millimeter (length) (measure) m: meter (length) mA: milliampere MS-MSG: MOSA engine driven welder with high frequency alternator MT: magnetothermic switch MT: grounding kit MTD: magnetothermic switch / GFI OH: heater (engine oil) for generating sets P: plus PAC: power electric frame PAR: device for double PB: battery holder PL: „pipe line“ welding PS: exhaust pipe extension PW: welder for polyethylene and propylene pipes QEA: automatic electric panel QEM: manual electric panel R: Ruggerini engine RVT: voltage electronic regulator S: symbol of EN 60974-1 S: Suzuki engine SKID: unit assembled on a base with no protection (no fairing) S-SC: silenced (faired) - silenced compact (faired) SX-SXC: supersilenced (faired and sound prof) - supersilenced compact (faired and super sound prof) T: thermic switch TC-TCM-TCPL: remote control TS: welder with asynchronous alternator V: Volt Y: Yanmar engine Y: three-phase auxiliary generation (symbol 3~)</p>
--	--

 Conformity CE	 EEC Sound power conformity	 EN 60974-1 conformity	 Triphase 3 ~	 Singlephase 1 ~	 Users' manual	 Information	 Various news
--	---	--	---	--	--	--	---

Equipment and optional

Engine	 Gasoline engine	 Diesel engine	 Air cooling	 Water cooling	 Manual recoil	 Electric start	 Battery 12 V			
Engine protection	 Engine protection	 Engine protection	 Engine protection	 Engine protection	 Engine protection	 Engine protection	 Siren	 Engine shut down (oil)	 Engine speed	
Engine alarms	 Oil level indicator	 Battery charger indicator	 Fuel level gauge/low fuel	 Low fuel indicator	 Oil temperature	 Warning light for preheating glow plugs	 Air filter blockage	 Belt breakage	 Over speed	 Control unit QEA
Generation	 Asynchronous alternator	 Synchronous alternator	 Generator high frequency	 Voltmeter	 Frequency-meter	 Ammeter	 Compound	 Voltmeter phase selector	 Electronic Voltage regulator	 Switch
Electric protection	 Circuit breaker/ Ground fault interrupter	 Circuit breaker	 Ground fault interrupter	 Thermal shut off	 Fuse	 Isolation monitoring				
Generation use	 Terminal strip	 3 ~ CEE Socket 400/230V EEC	 1 ~ CEE Socket 230/110/48V EEC	 1 ~ Schuko Socket 230V Schuko	 Socket 48V EEC	 Battery charger	 Engine booster			
Welding control	 Arc control	 Welding with covered electrode	 Welding current electr. regulation	 Base current diode bridge	 Polarity inverter	 CC/CV selector				
Various devices	 Hour counter	 Ready for TC	 Ground connection point	 Emergency stop button	 Central lifting eye					
Various	 Standard equipment	 Options on request				 D.C.	 A.C.	 Plus	 Minus	 Maintenance Time
Optionals	 Trolley	 Site tow	 Welding cables	 Remote control						

 The installation and the general advice concerning the operations, are finalized to the correct use of the machine, in the place where it is used as generator group and/or welder.

ENGINE	Stop engine when fueling	CHECKING BOARD	Do not touch electric devices if you are barefoot or with wet clothes.
	Do not smoke, avoid flames, sparks or electric tools when fueling.		Always keep off leaning surfaces during work operations
	Unscrew the cap slowly to let out the fuel vapours.		Static electricity can damage the parts on the circuit.
	Slowly unscrew the cooling liquid tap if the liquid must be topped up.		An electric shock can kill
	The vapor and the heated cooling liquid under pressure can burn face, eyes, skin.		
	Do not fill tank completely.		
	Wipe up spilled fuel before starting engine.		
	Shut off fuel of tank when moving machine (where it is assembled). Avoid spilling fuel on hot engine.		
Sparks may cause the explosion of battery vapours			



FIRST AID. In case the operator should be sprayed by accident, from corrosive liquids a/o hot toxic gas or whatever event which may cause serious injuries or death, predispose the first aid in accordance with the ruling labour accident standards or of local instructions.

















Skin contact	Wash with water and soap
Eyes contact	Irrigate with plenty of water, if the irritation persists contact a specialist
Ingestion	Do not induce vomit as to avoid the intake of vomit into the lungs, send for a doctor
Suction of liquids from lungs	If you suppose that vomit has entered the lungs (as in case of spontaneous vomit) take the subject to the hospital with the utmost urgency
Inhalation	In case of exposure to high concentration of vapours take immediately to a non polluted zone the person involved

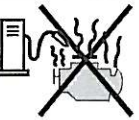

FIRE PREVENTION. In case the working zone, for whatsoever cause goes on fire with flames liable to cause severe wounds or death, follow the first aid as described by the ruling norms or local ones.

EXTINCTION MEANS

Appropriated	Carbonate anhydride (or carbon dioxide) powder, foam, nebulized water
Not to be used	Avoid the use of water jets
Other indications	Cover eventual shedding not on fire with foam or sand, use water jets to cool off the surfaces close to the fire
Particular protection	Wear an autorespiratory mask when heavy smoke is present
Useful warnings	Avoid, by appropriate means to have oil sprays over metallic hot surfaces or over electric contacts (switches, plugs, etc.). In case of oil sprinkling from pressure circuits, keep in mind that the inflammability point is very low.

 WARNING					 CAUTION		 DANGEROUS
							
							

 **WARNING**

THE MACHINE MUST NOT BE USED IN AREAS WITH EXPLOSIVE ATMOSPHERE



INSTALLATION AND ADVICE BEFORE USE

GASOLINE ENGINES

- Use in open space, air swept or vent exhaust gases, which contain the deathly carbone oxyde, far from the work area.

DIESEL ENGINES

- Use in open space, air swept or vent exhaust gases far from the work area.

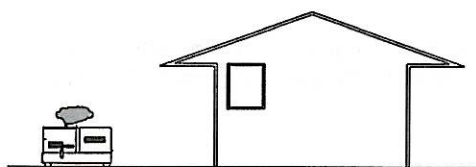
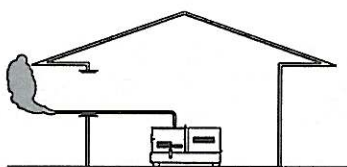
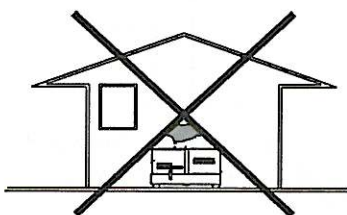

POSITION

Place the machine on a level surface at a distance of at least 1,5 m from buildings or other plants.

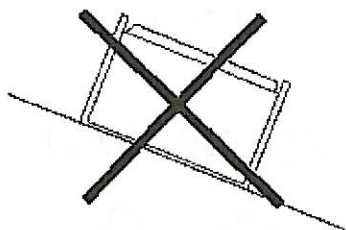

Maximum leaning of the machine (in case of dislevel)

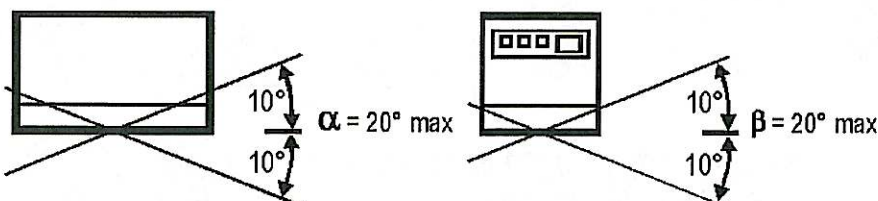

Check that the air gets changed completely and the hot air sent out does not come back inside the set so as to cause a dangerous increase of the temperature.

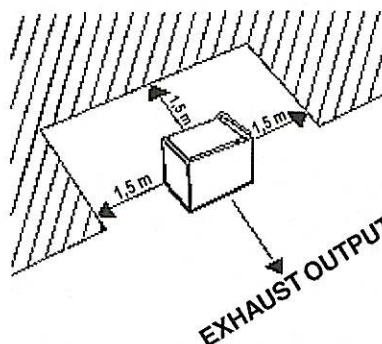

- ☞ Make sure that the machine does not move during the work: **block** it possibly with tools and/or devices made to this purpose.

MOVES OF THE MACHINE

- ☞ At any move check that the engine is **off**, that there are no connections with cables which impede the moves.

PLACE OF THE MACHINE



In spots where it often rains and/or there are flooded areas, do **not** put the machine:

- in the bad weather
- in flooded places.

Protect all the electric parts at risk, because water infiltrations could cause short circuits with damages at persons and/or things.

The protection degree of the machine is put on the data plate and in this manual at page "Technical Data".

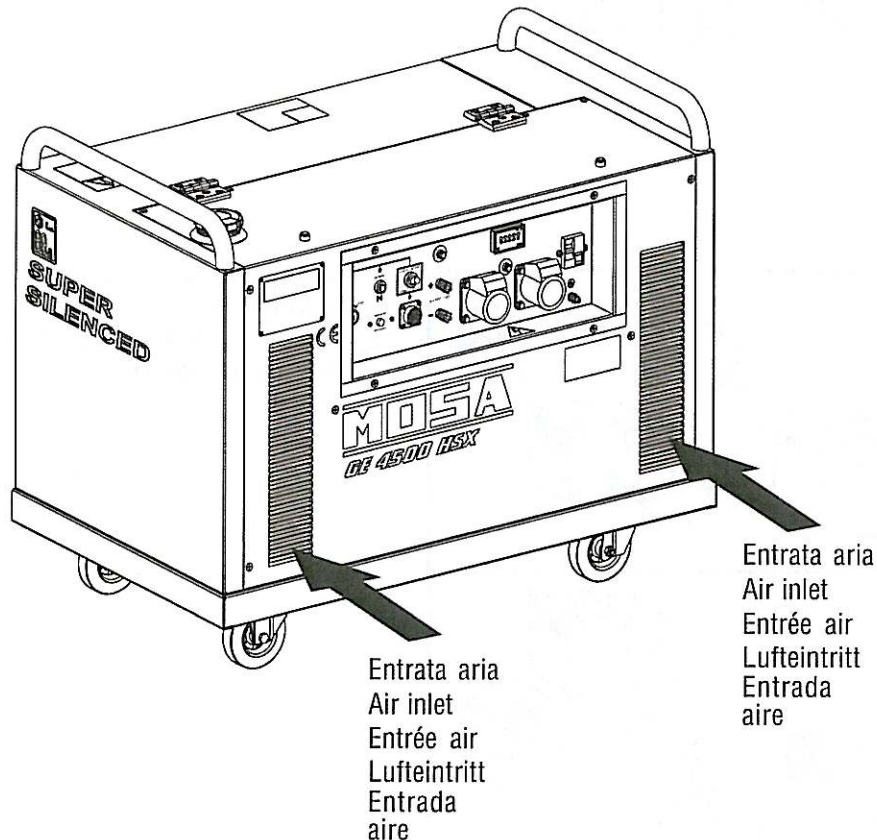
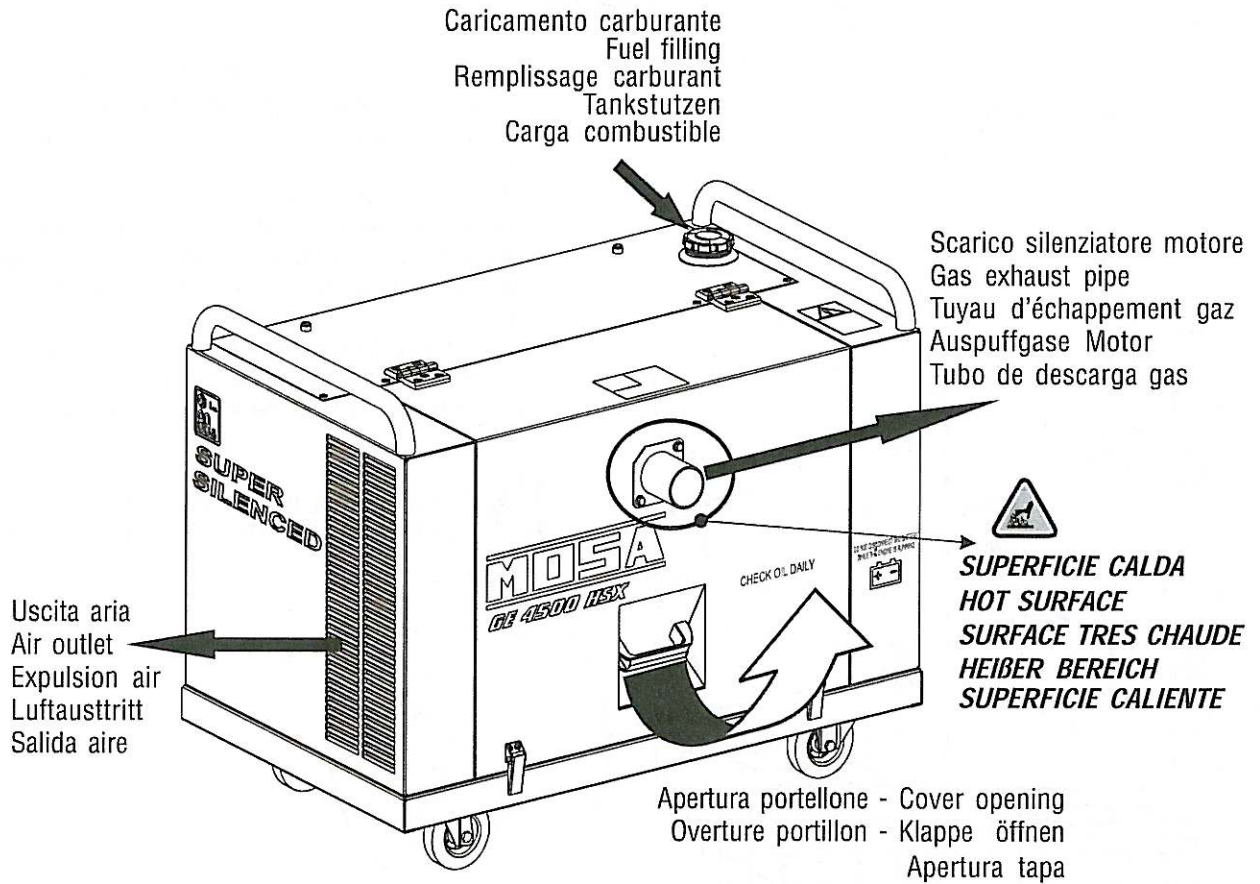



NOTE

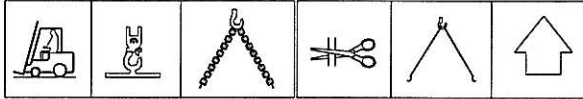

Be sure that the lifting devices are: correctly mounted, adequate for the weight of the machine with its packaging, and conforms to local rules and regulations.

When receiving the goods make sure that the product has not suffered damage during the transport, that there has not been rough handling or taking away of parts contained inside the packing or in the set.

In case you find damages, rough handling or absence of parts (envelopes, manuals, etc.), we advise you to inform immediately our Technical Service.



For eliminating the packing materials, the User must keep to the norms in force in his country.

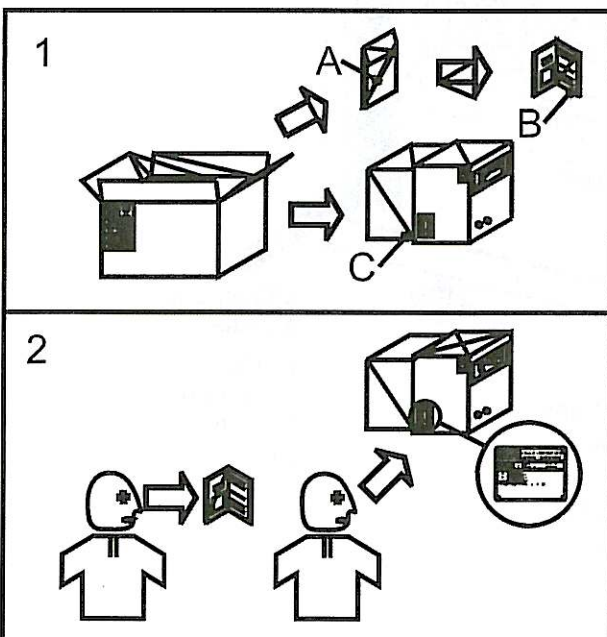
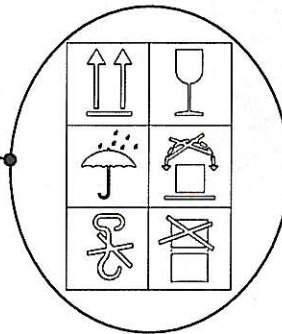
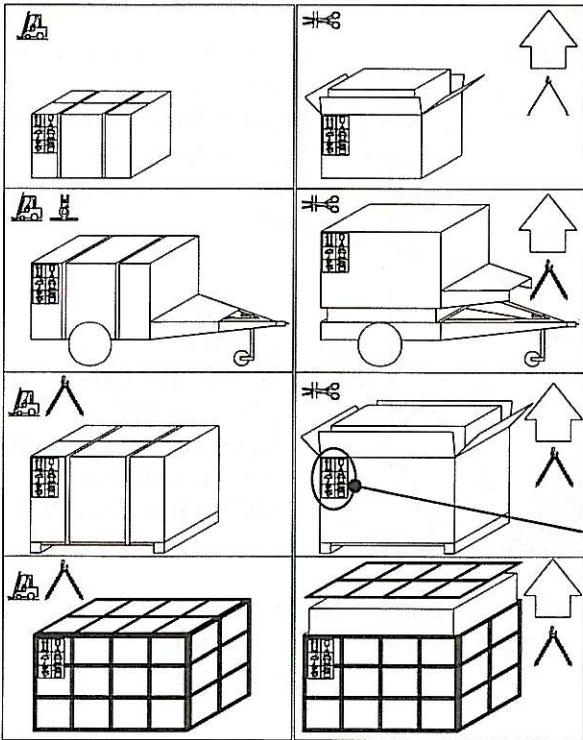

- 1) Take the machine (C) out of the shipment packing. Take out of the envelope (A) the user's manual (B).
- 2) Read: the user's manual (B), the plates fixed on the machine, the data plate.



**NOTE**

In case you should transport or move the machine, keep to the instructions as per the figures.

Make the transportation when the machine has **no** petrol in its tank, **no** oil in the engine and and electrolyte in the battery.

Be sure that the lifting devices are: correctly mounted, adequate for the weight of the machine with it's packaging, and conform to local rules and regulations.

Only authorized persons involved in the transport of the machine should be in the area of movement.

DO NOT LOAD OTHER PARTS WHICH CAN MODIFY WEIGHT AND BARICENTER POSITION.

IT IS STRICTLY FORBIDDEN TO DRAG THE MACHINE MANUALLY OR TOW IT BY ANY VEHICLE (model with no CTM accessory).

If you did not keep to the instructions, you could damage the structure of the machine.

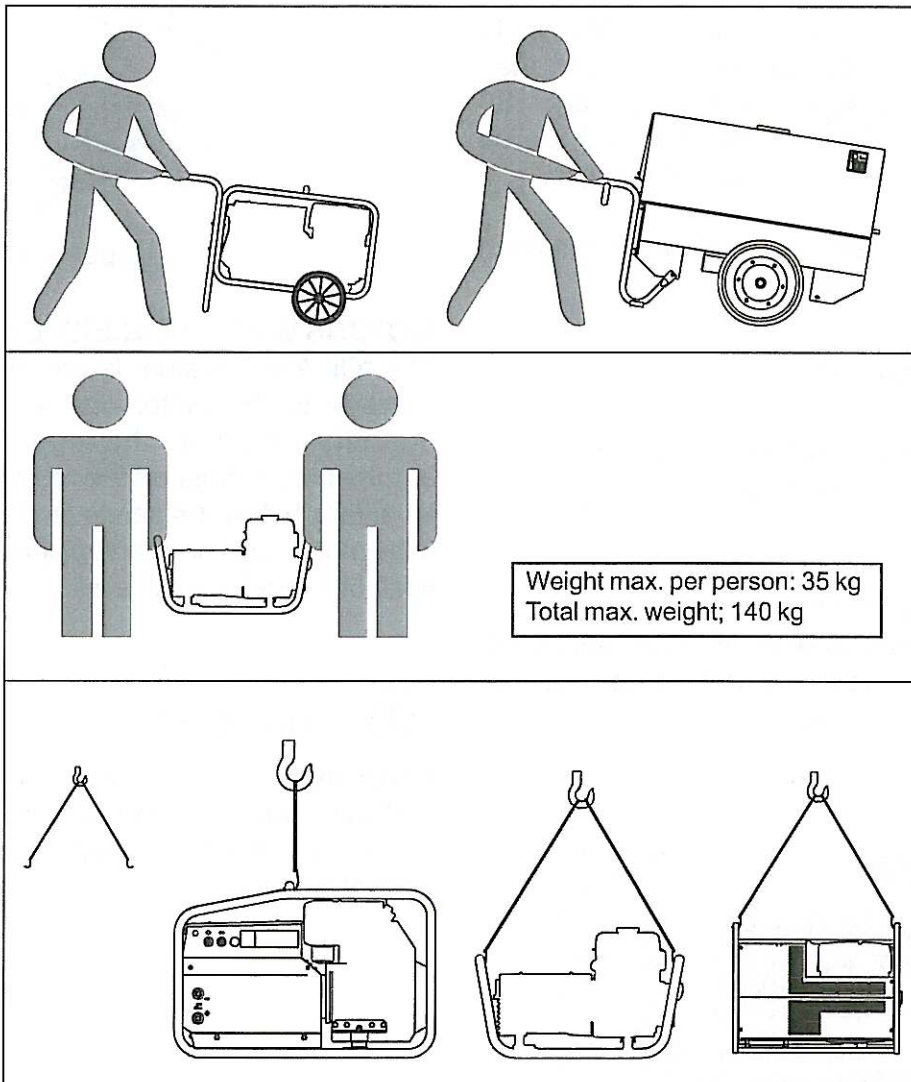



BATTERY



WARNING



Sulphuric acid is corrosive. Protect hands, eyes, clothing, etc.

Remove the battery from the machine before undertaking any operations.

Note: Damage caused by the spilling of acid will VOID the warranty.

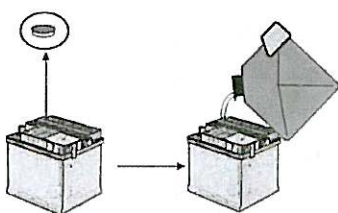

Fill the battery (S1) with electrolyte up to the max. level; then wait approx. 30 minutes and top up with electrolyte.

If any acid is spilled, rinse with abundant fresh water before re-assembling.



LUBRICANT

Please refer to the motor operating manual for the recommended viscosity.

RECOMMENDED OIL

MOSA recommends selecting **AGIP** engine oil. Refer to the label on the motor for the recommended products.

PRODOTTI RACCOMANDATI RECOMMENDED PRODUCTS	
AGIP SUPERDIESEL 15W/40 API CF4-SG	OLIO MOTORE DIESEL DIESEL ENGINE OIL
AGIP SUPERMOTOROIL 20W/50 API CC-SF	OLIO MOTORE BENZINA GASOLINE ENGINE OIL
AGIP ANTIFREEZE EXTRA INIBITE ETHYLENE GLYCOL (50% + 50% H ₂ O)	CIRCUITO DI RAFFREDDAMENTO COOLING CIRCUIT (CUNA NC 956-16 ED 97)

To check the oil level:

1. Remove the oil-fill tap (24) and clean the dip-stick (23).
2. Insert the dip-stick into the oil filler without screwing it in.
3. If the oil level is low, fill with recommended oil up to the top of the oil filler using the syringe supplied.

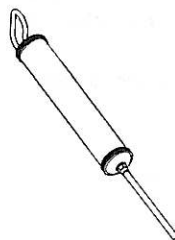

Oil fill tap / dip-stick

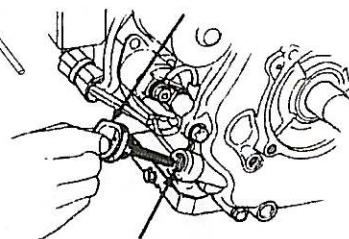

Upper oil level

MOTORS WITH OIL ALERT DEVICE

The "Oil Alert" system is designed to prevent damage to the motor due to an insufficient quantity of oil in the cup. This system automatically shuts off the motor before the oil level falls below the safety limit.

If the motor does not start up again after shutting itself off, check the oil level.



AIR FILTER

Check that the dry air filter is correctly installed and that there are no leaks around the filter which could lead to infiltrations of non-filtered air to the inside of the motor.



**FUEL****WARNING**

Gasoline is highly flammable. Refuel with motor shut off in a flat surfaced well-ventilated area. Do not refuel in the presence of flames. Avoid spilling fuel.



Any eventual spilled fuel and fumes are flammable. Clean any dispersions of fuel before starting up the motor.

Fill the tank with gasoline for automobiles (preferably lead free or with low lead content in order to reduce deposits in the combustion chamber to a minimum).

For further details on the type of gasoline to use, see the motor operating manual supplied. Do not fill the tank completely; leave a space of approx. 10 mm between the fuel level and the wall of the tank to allow for expansion.

**GROUND CONNECTION**

Proper grounding is obligatory for all models featuring a ground fault interruptor [G.F.I.] switch. This safety device functions correctly only if the machine is grounded.

☛ Use a good quality grounding cable and connect it to the machine's ground terminal (12). Abide by local norms and/or laws concerning safety and electrical installations. When these operations have been carried out, the unit can be started up for operation.

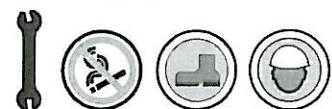



check before each start-up



START-UP FROM "LOCAL/START" FRONT PANEL

1. Position the LOCAL START / REMOTE START (I6) selector on LOCAL START;
2. make sure the load plugs are disconnected

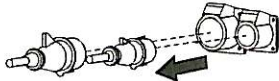

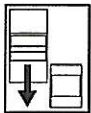

or the G.F.I. switch (D) is not inserted

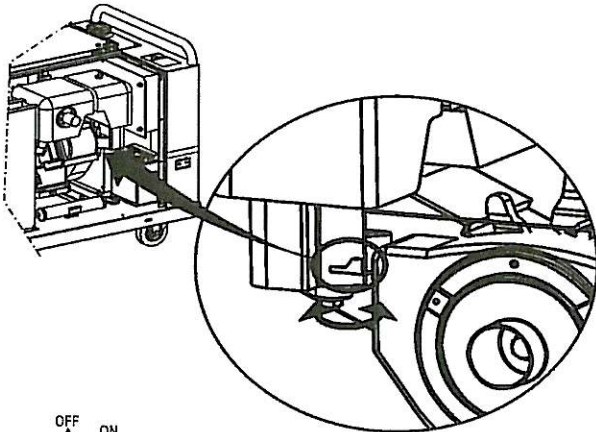

(intervention/insertion lever facing down), so as to ensure the motor's start-up without any loads inserted;

3. open the gasoline tap (87) by turning it towards the inside;



4.  turn the start-up key (Q1) to the ON position;

5. press the CHOKE button (L6) and simultaneously turn the key to the START position, holding it until the motor has started;

6. leave the key in the ON position, then wait a few moments before releasing the choke button; if the motor tends to shut itself off press the choke button once again until the motor has properly started up.

- Do not use the CHOKE button if the motor is hot or if the ambient temperature is sufficiently high.

In case of unsuccessful start-up, do not insist for longer than 5 seconds. Wait 10 seconds before attempting another start-up .

REMOTE START

The unit can also be started by means of the remote TCM 5 control device, or through the EAS 5 automatic intervention panel.

1. Position the LOCAL START / REMOTE START (I6) selector on REMOTE START;
2. Connect to the EAS (B3) connector the TCM 5 or the EAS 5 panel.

Start-up with TCM 5

Use the controls located on the TCM 5 in the same manner as described for start-up from the front panel.

Start-up with EAS 5

The EAS 5 panel will automatically manage the start-up.

See operating manual for EAS 5 panel.



CAUTION

RUNNING-IN

During the first 50 hours of operation, do not use more than 60% of the maximum output power of the unit and check the oil level frequently, in any case please stick to the rules given in the engine use manual.

SHUT-DOWN FROM FRONT PANEL

1. Position the LOCAL START /REMOTE START (I6) selector on LOCAL START;

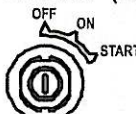
2.  to shut down the motor in an emergency situation, turn the key (Q1) to the OFF position;

3. to stop the motor under normal conditions, proceed as follows:

3a. interrupt the power source, switching off all tools connected. If a tool does not feature a power switch, lower the G.F.I. switch lever (D);

3b. allow the motor to run without any load for a few minutes;

3c. turn the key (Q1) to the OFF position.

SHUT-DOWN FROM REMOTE



WARNING

The start-up selector (I6) LOCAL START / REMOTE START enables the start-up and stop controls for the selected position.

From the REMOTE START position, the start-up key on the front panel is completely disabled; to stop the generator, use the controls on the TCM or EAS panel.

SHUT-DOWN with TCM 5

Follow the operating procedures for shut-down under normal or emergency conditions, as described in the paragraph SHUT-DOWN FROM FRONT PANEL, using the key (Q1) on the TCM 5.

SHUT-DOWN with EAS 5

Shut-down is controlled automatically. See operating manual for the EAS 5 panel. At the end of each use of the generator, close the gasoline tap (87).

In case of an extended period of inactivity of the generator, switch off the motor by closing the gasoline tap (87); this precautionary measure serves to avoid probable deposits in the carburettor.

NB.: as a safety measure the start-up key must be entrusted to qualified personnel.

The unit can also be shut down by means of the TCM 5 remote control or EAS 5 panel.

- Check that the EAS (B3) connector is connected to the cable from the TCM 5 or EAS 5 panel.
- Verify or position the LOCAL START / REMOTE START (I6) selector on REMOTE START.

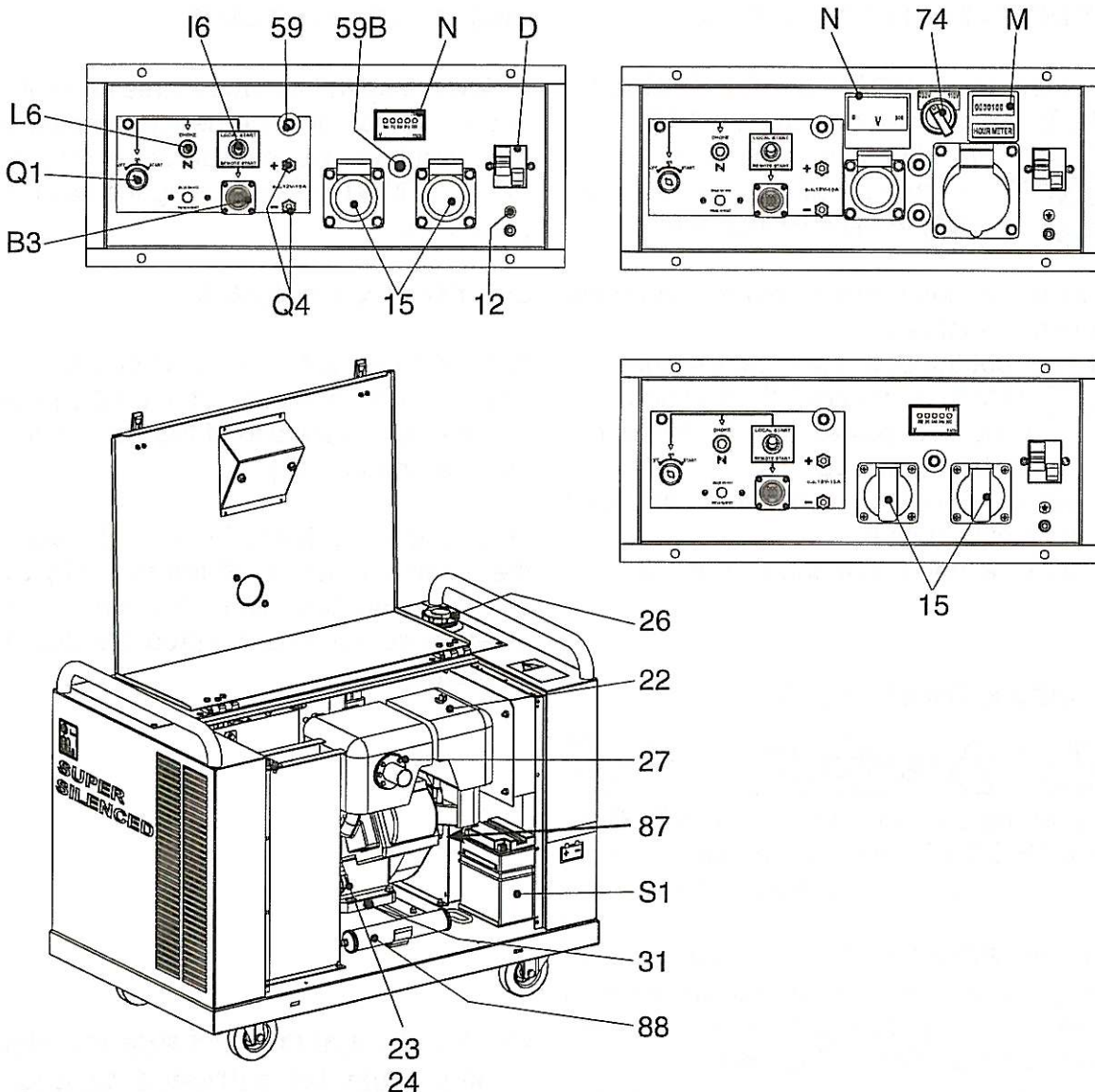

Pos.	Descrizione	Description	Description	Descripción
12	Pres a di messa a terra	Earth terminal	Prise de mise à terre	Toma de puesta a tierra
15	Pres a di corrente in c.a.	A.C. socket	Prises de courant en c.a.	Toma de corriente en c.a
22	Filtro aria motore	Engine air filter	Filtre air moteur	Filtro aire motor
23	Asta livello olio motore	Oil level dipstick	Jauge niveau huile moteur	Aguja nivel aceite motor
24	Tappo caricamento olio motore	Engine oil reservoir cap	Bouchon remplissage huile moteur	Tapón llenado aceite motor
26	Tappo serbatoio	Fuel tank cap	Bouchon réservoir	Tapón depósito
27	Silenziatore di scarico	Muffler	Silencieux d'échappement	Silenciador de descarga
31	Tappo scarico olio motore	Oil drain tap	Bouchon décharge huile moteur	Tapón vaciado aceite motor
59	Protezione termica c.b.	Battery charger thermal switch	Protection thermique c.b.	Protección térmica c.b..
59B	Protezione termica corrente aux	Aux current thermal switch	Protection thermique courant aux.	Protección térmica corr. aux
74	Commut. sequenza operat./funz.	Operating mode selector	Commut.séquence opérat./fonct.	Conmut.secuencia operat./func
87	Rubinetto carburante	Fuel cock	Robinet de l'essence	Grifo de combustible
88	Siringa olio	Oil syringe	Siringue huile	
B3	Connettore E.A.S.	E.A.S. connector	Connecteur E.A.S.	Conector E.A.S.
D	Interruttore differenziale (30mA)	G.F.I.	Interrupteur différentiel	Interruptor diferencial (30 mA)
I6	Selettore Start Local/Remote	Start Local/Remote selector	Selecteur Start Local/Remote	Selector Start Local/Remote
L6	Pulsante choke	Choke button	Bouton Choke	Pulsador Choke
M	Conraore	Hour counter	Compte-heures	Cuentahoras
N	Voltmetro	Voltmeter	Voltmètre	Voltímetro
Q1	Chiave di avviamento	Starter key	Clé de démarrage	Llave de arranque
Q4	Prese carica batteria	Battery charge sockets	Prises charge batterie	Toma carga batería
S1	Batteria	Battery	Batterie	Batería



WARNING

It is absolutely forbidden to connect the unit to the public mains and/or another electrical power source .

Areas for which access by non-authorized personnel is **forbidden** are:

- the control panel (at the front) - the endothermic motor discharge.

GENERATION IN AC (ALTERNATING CURRENT)

Make certain of the efficiency of the ground connection (12).

- See page M25.1 -.

230V version

Position the G.F.I. switch to ON.

- ☞ Tension is now immediately available to the c.c sockets.

Verify that the LED voltmeter displays the nominal voltage value + 10%

(e.g. nom. V=230V AC - LED on 240/250V AC).

230/110V version

- 110 V switch position

It is available only the 110 V voltage in outlet; from the AC socket (15) it is possible to take the plate nominal power.

- Switch 230 V position

Both 110 V and 230 V voltages are available from the outlet sockets (15), from the 230 V socket it is possible to take the plate nominal power whereas only the half from the 110 V.

In case of contemporary use of both generations the total amount of the two powers must not be over the nominal one.

The GFI is put in protection of the 230 V voltage, before and after every use connect and disconnect the GFI using its lever.

- ☞ At the start the 110 V voltage is immediately available from the outlet on both switch positions (74); therefore it is advisable to start the set without introducing loads.

- Check that the voltmeter (N) shows the value of the selected voltage, with a tolerance of about + 10%.

- The hourmeter will show the working hours of the engine.

Connect the electric devices to be powered to the AC sockets, using suitable plugs and cables in prime condition.

- ☞ Verify that the electrical characteristics of the tension/frequency/power device are compatible with those of the generator.

Low frequency and/or voltage can damage some electrical devices irreparably.

Verify that the ground terminal for the plug is properly grounded and connected to the electrical appliance/tool to be powered.

- ☞ For double insulation devices with the symbol , the plug's ground terminal **must not** be grounded.

THERMOPROTECTION

The generator is protected against overloads by the thermoprotection (59B).

When current is exceeded, the protection feature intervenes to cut off tension to the AC sockets.

- ☞ Notes: the intervention of the thermoprotection feature is not instantaneous, but reacts according to an overcurrent/time characteristic, whereby the greater the overcurrent the quicker the intervention.

In case of intervention by the protection feature, verify that the total power for the loads connected does not exceed the declared rating; decrease if necessary. Disconnect the loads and wait a few minutes to allow the thermo-protection to cool down.

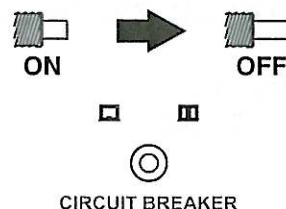

Reset the protection feature by pressing the central pole, then connect the load once again.

If the protection should intervene once more, replace it with another one with matching intervention current specifications and/or contact the Service Department.

- ☞ Note: do not forcibly press the central pole on the thermoprotection to inhibit its intervention, as this could **damage** the unit's alternator irreparably.



GROUND FAULT INTERRUPTOR SWITCH

The high-sensitivity ground fault interruptor switch [G.F.I.] (30mA) (D), guarantees protection against indirect contacts due to faulty ground currents .

When the G.F.I. switch picks up a faulty ground current that is higher than 30mA, it intervenes by immediately cutting off tension to the AC sockets.

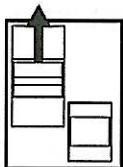

In case of intervention by this protection feature, reset the G.F.I. switch, bringing the lever to the ON position.

In case of another intervention, verify that no faulty tools are connected, or replace the G.F.I. switch with another of matching specifications and/or contact the Service Department.

Notes: verify the operation of the G.F.I. switch at least once a month by pressing the TEST button.

The generator must be running and the differential lever in the ON position.

GENERATION IN C.C. (Continuous Current)

Maximum power in c.c.:

$$P = 120W - V = 12V \text{ AC}$$

$$I = 10A$$

Generation in c.c. is mainly used to recharge lead batteries.

- Verify that the battery to be charged is not a dry battery, and that it is 12V c.c.
- Position the generator and battery on a flat surface and distant from one another.



WARNING

It is dangerous to handle a lead battery; follow the procedures outlined on page M 25.

- Connect the battery recharge cables one at a time, avoiding accidental contacts between them.

Note: use cables with a minimum section of 6 mm².

- Start the motor.
- Once recharging is complete, proceed in opposite sequence, switching off the motor and disconnecting the cables, etc.

THERMOPROTECTION

The 12V c.c. output is protected against overloads by the thermoprotection device (59). When current is exceeded, the protection feature intervenes to cut off tension to the c.c. terminals (Q4).

Notes: the intervention of the thermoprotection feature is not instantaneous, but reacts according to an overcurrent/time characteristic, whereby the greater the overcurrent the quicker the intervention.

In case of intervention by the protection feature, verify that:

- the c.c. terminal /battery connections respect the polarities;
- the battery is not faulty or has a short-circuited element;
- the battery level is not too low, with the consequent recharge current being too high.

Eliminate the cause and wait a few minutes to allow the thermoprotection to cool down.

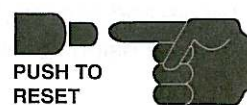

Reset the protection feature by pressing the central pole. If the protection should intervene once more, replace it with another one with matching intervention current specifications and/or contact the Service Department.





MAKE SURE

When the TCM 5 5D-6 is used, it is not possible to connect the E.A.S automatic intervention unit.

USE OF THE REMOTE CONTROL TCM 5

The coupling of the TCM 5 with the generating set, permits to work far from the set itself. The remote control is connected to the front plate, with a multiple connector.

The TCM 5 assures the following functions:

- starting (starting key Q1)
- stop (starting key Q1)
- choke control (L6)

- 1) the position of the selector LOCAL START/REMOTE START (I6) on the generating sets GE 4500 HSX and GE 4500 SX-EAS must be on the position "REMOTE START".
- 2) The position of the key (Q1) on the generating set GE 4500 SX-EAS must be on the position "ON"

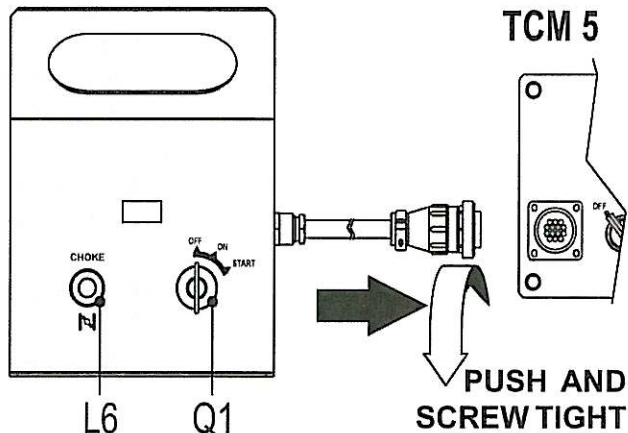

USE OF THE REMOTE CONTROL TCM 5D

The coupling of the TCM 5D with the generating set, ready for remot starting, permits to work far from the set itself.

The remote control is connected to the front plate, and/or rear plate, with a multiple connector.

The TCM 5D assures the following functions:

- starting (starting key Q1)
- acceleration (selector 16)
- stop (starting key Q1)
- indication of oil low pressure (warning light O1)

To stop the set, move the accelerator lever (16) to the minimum position, then turn the key to "OFF" position.

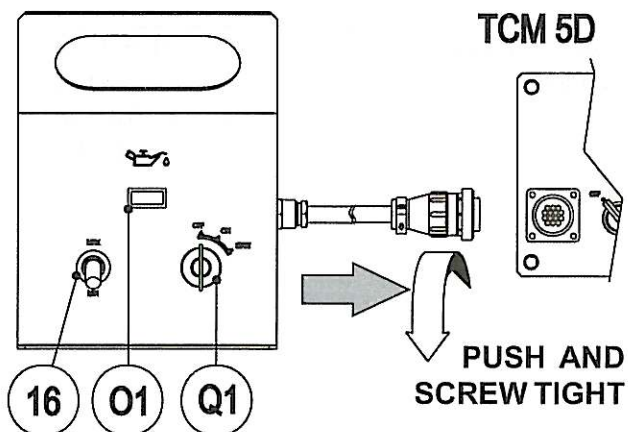

USE OF THE REMOTE CONTROL TCM 6

The coupling of the TCM 5D with the generating set, ready for remot starting, permits to work far from the set itself.

The remote control is connected to the front plate, and/or rear plate, with a multiple connector.

The TCM 5D assures the following functions:

- starting (starting key Q1)
- stop (starting key Q1)
- indication of oil low pressure (warning light O1)

To stop the set turn the key to the position."OFF". O1)

Per l'arresto del motore portare la chiave sulla posizione "OFF".

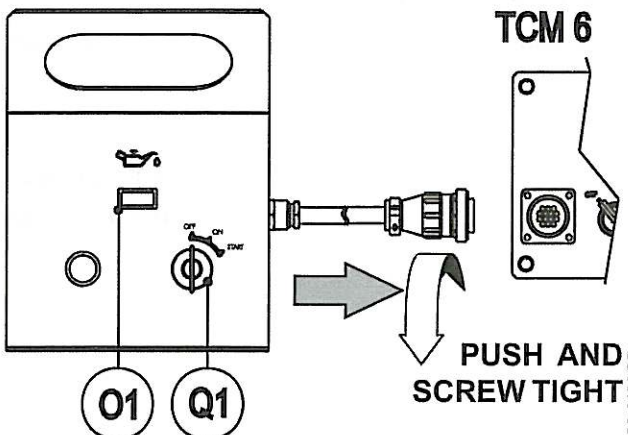

Problem	Possible cause	Solution
The motor does not start up, or starts up and then stops immediately	<ol style="list-style-type: none"> 1) Key and start-up selector in the wrong positions 2) Lack of or insufficient oil in the motor 3) Faulty motor stopping device (oil-alert) 4) Lack of fuel in tank or fuel tap closed 5) Dirty or faulty spark plug 6) Battery not activated, low or faulty 7) Faulty start relay 8) Cold motor 9) Other causes 	<ol style="list-style-type: none"> 1) Verify start-up procedure in the Operating Manual 2) Refill or top off 3) Replace 4) Refill the tank. Open the fuel tap 5) Clean or check and eventually replace 6) Activate, recharge, or replace the battery 7) Replace 8) Hold down the CHOKE button, after start-up, for a longer period of time 9) Consult the motor Operating Manual.
Lack of tension to the AC sockets	<ol style="list-style-type: none"> 1) G.F.I. switch in the OFF position 2) Intervention of G.F.I. switch due to faulty ground current 3) Faulty G.F.I. switch 	<ol style="list-style-type: none"> 1) Position to ON 2) Disconnect load from AC sockets. Position the G.F.I. switch to ON; if the switch intervenes once again, the fault is on board the machine. Contrarily, the cause of the G.F.I. switch intervention is due to a faulty ground current in the load or connection cable. Find and remove the fault. 3) Replace
Lack of tension to the AC sockets	<ol style="list-style-type: none"> 1) Intervention of circuit breaker (thermoprotection) 2) Faulty thermoprotection 3) Faulty alternator 	<ol style="list-style-type: none"> 1) Check total power supplied by generator; if greater than the power reported on the specification nameplate, decrease the load 2) Replace 3) Check rotating diode windings, alternator excitation capacitor. See specific alternator manual.

<i>Problem</i>	<i>Possible cause</i>	<i>Solution</i>
No-load output voltage too low or too high	1) Incorrect motor speed 2) Faulty alternator	1) Set the motor's no-load speed 2) Check rotating diode windings, alternator excitation capacitor. See specific alternator manual.
No-load voltage OK, too low with load	1) Faulty alternator 2) Overload 3) Number of motor rpm too low	1) Replace rotating diodes 2) Check total load and eventually decrease 3) Check the fuel supply circuit. See Motor Operating manual.
Lack of tension to the c.c. terminals	1) Thermoprotection intervention 2) Faulty thermoprotection 3) Faulty diode bridge rectifier 4) Faulty alternator winding	1) Check the load current and eventually decrease it. 2) Replace 3) Replace 4) Replace
The battery discharges itself frequently	1) Intervention of battery charge thermoprotection 2) Faulty battery charge circuit 3) If connected to EAS5 automatic panel.	1) Reset thermoprotection circuit breaker. In case of new intervention, check battery. 2) Check: battery charge winding, battery charge diode, T1 and M3 respectively on electrical diagram. Replace. 3) Replace panel (faulty battery charge circuit on EAS 5 panel).

⚠ WARNING



MOVING PARTS can injure

- Have **qualified** personnel do maintenance and troubleshooting work.
 - Stop the engine before doing any work inside the machine. If for any reason the machine must be operated while working inside, **pay attention** moving parts, hot parts (exhaust manifold and muffler, etc.) electrical parts which may be unprotected when the machine is open.
 - Remove guards only when necessary to perform maintenance, and replace them when the maintenance requiring their removal is complete.
 - Use suitable tools and clothes.
 - Do not modify the components if not authorized.
- See pag. M1.1 -



HOT surface can hurt you

By maintenance at care of the utilizer we intend all the operatios concerning the verification of mechanical parts, electrical parts and of the fluids subject to use or consumption during the normal operation of the machine.

For what concerns the fluids we must consider as maintenance even the periodical change and or the refills eventually necessary.

The routine cleaning of the machine is also considered maintenance.

The repairs **cannot be considered** among the maintenance activities, i.e. the replacement of parts subject to occasional damages and the replacement of electric and mechanic components consumed in normal use, by the Assistance Authorized Center as well as by MOSA.

The replacement of tires (for machines equipped with trolleys) must be considered as repair since it is not delivered as standard equipment any lifting system.

For the maintenance of the gasoline or Diesel engine please refer to the specific manual supplied with the unit.

The periodic maintenance should be performed according to the schedule shown in the engine manual. An optional hour counter (M) is available to simplify the determination of the working hours.

Every day check the oil level in the engine and in the air filter (if at oil bath). Make sure that these are no obstructions in the aspiration/exhaust ducts of the alternator, in the engine or in the cover (pieces of material, leaves or other).

See page M21 and M26.



NOTE

THE ENGINE PROTECTION DO NOT WORK WHEN THE OIL IS OF LOW QUALITY BECAUSE NOT CHARGED REGULARLY AT INTERVALS AS PRESCRIBED IN THE OWNER'S ENGINE MANUAL.



UNITS WITH ELECTRIC STARTER

Check periodically the electrolyte level in the battery, especially after long periods of inactivity.

☞ **ATTENTION:** the battery must have all its elements in good condition and must be filled with electrolyte.

The battery is automatically charged while the engine is running at speed.

☞ **N.B.:** In the models with safety protections, in case the battery is not reloaded, check the thermic protection (59A) reload it if it is the case as well as the fuse (35).

PROCEDURE FOR RECHARGING A BATTERY

Keep to the advice indicated page - M36 -

Take off the breather caps of the battery.

Check the electrolyte level in all the elements of the battery.

If necessary, add up **distilled water** to have the liquid at the recommended level.

Put back the breather caps of the battery.

Use a densimeter to determine the charge state of the battery.

SPECIFIC WEIGHT	CHARGE PERCENTAGE
1.265	100%
1.230	75%
1.200	50%
1.170	25%

MODELS WITH DRY AIR FILTER (CLEANING)

Replace the air filter cartridge every 200 hours when using the unit in a clean environment.

In a dusty environment, the filter cartridge must be replaced every 100 hours.

ALTERNATOR (brushless)

No other further periodical maintenance is necessary, as the alternator has no brushes or slip rings, and the output regulation is entirely electronic.

ALTERNATOR (with brushless)

Control the wear and the position of the carbon brushes at regular intervals (refer to the alternator manual supplied with the machine for details).

MODEL WITH COOLING LIQUID

Every day check the cooling liquid level.

Verify each day freezing liquid and check periodically the radiator state (losses obstructions for air circulation etc.)

☞ **N.B.:** all warning and decals should be checked once a year and **replaced** if missing or unreadable.

Check periodically the condition of the cables and tighten the connections.

In case the machine should not be used for more than 30 days, make shure that the room in which it is stored presents a suitable shelter from heat sources, weather changes or anything which can cause rust, corrosion or damages to the machine. See page M45.

In the maintenance operations avoid that polluting substances, liquids, exhausted oils, etc. bring damage to people or things or can cause negative effects to surroindings, health or safety respecting completely the laws and/or dispositions in force in the place.

In case of necessity for first aid and of fire prevention, see page. M2.5.

⚠ IMPORTANT

In the maintenance operations avoid that polluting substances, liquids, exhausted oils, etc. bring damage to people or things or can cause negative effects to surroindings, health or safety respecting completely the laws and/or dispositions in force in the place.



	EVERY WEEK	EVERY MONTH AND/OR AFTER INTERVENTION ON LOAD	EVERY YEAR AND/OR AT PRESCRIBED TIMES
1. TEST or AUTOMATIC TEST cycle to keep the generating set constantly operative	○		
2. Check all levels: engine oil, fuel level, battery electrolyte,, if necessary top it up.		○	
3. Keep to the advice given in manuals: engine, alternator, and machine specific one.			○



ATTENTION

Before any intervention on the generating set, KEEP TO FOLLOWING:

- Preset the unit so as to execute the maintenance of the set.
- Disconnect the three phase, single phase plugs and/or the wires to the feed box
- Disconnect the plug of the connection cable to the EAS unit and/or to PAC 150..

After having effected the routine checks, reset all electric connections and follow the indications for a new working cycle

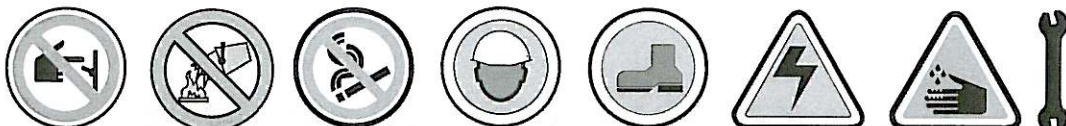

In case the machine should not be used for more than 30 days, make sure that the room in which it is stored presents a suitable shelter from heat sources, weather changes or anything which can cause rust, corrosion or damages to the machine.

☞ Have **qualified** personnel prepare the machine for storage.

GASOLINE ENGINE

Start the engine: It will run until it stops due to the lack of fuel.

Drain the oil from the engine sump and fill it with new oil (see page M25).

Pour about 10 cc of oil into the spark plug hole and screw the spark plug, after having rotated the crankshaft several times.

Rotate the crankshaft slowly until you feel a certain compression, then leave it.

In case the battery, for the electric start, is assembled, disconnect it.

Clean the covers and all the other parts of the machine carefully.

Protect the machine with a plastic hood and store it in a dry place.

DIESEL ENGINE

For short periods of time it is advisable, about every 10 days, to make the machine work with load for 15-30 minutes, for a correct distribution of the lubricant, to recharge the battery and to prevent any possible blocking of the injection system.

For long periods of inactivity, turn to the after sales service of the engine manufacturer.

Clean the covers and all the other parts of the machine carefully.

Protect the machine with a plastic hood and store it in a dry place.

In case of necessity for first aid and of fire prevention, see page. M2.5.



IMPORTANT



In the storage operations avoid that polluting substances, liquids, exhausted oils, etc. bring damage to people or things or can cause negative effects to surroundings, health or safety respecting completely the laws and/or dispositions in force in the place.



☞ Have **qualified** personnel disassemble the machine and dispose of the parts, including the oil, fuel, etc., in a correct manner when it is to be taken out of service.

As cust off we intend all operations to be made, at utilizer's care, at the end of the use of the machine. This comprises the dismantling of the machine, the subdivision of the several components for a further reutilization or for getting rid of them, the eventual packing and transportation of the eliminated parts up to their delivery to the store, or to the bureau encharged to the cust off or to the storage office, etc.

The several operations concerning the cust off, involve the manipulation of fluids potentially dangerous such as: lubricating oil and battery electrolyte.

The dismantling of metallic parts liable to cause injuries or wounds, must be made wearing heavy gloves and using suitable tools.

The getting rid of the various components of the machine must be made accordingly to rules in force of law a/o local rules.

Particular attention must be paid when getting rid of:

lubricating oils, battery electrolyte, and inflammable liquids such as fuel, cooling liquid.

The machine user is responsible for the observance of the norms concerning the environment conditions with regard to the elimination of the machine being cust off and of all its components.

In case the machine should be cust off without any previous disassembly it is however compulsory to remove:

- tank fuel
- engine lubricating oil
- cooling liquid from the engine
- battery

NOTE: MOSA is involved with custing off the machine **only** for the second hand ones, when not reparable.

This, of course, after authorization.

In case of necessity for first aid and fire prevention, see page M2.5.



IMPORTANT



In the cust-off operations avoid that polluting substances, liquids, exhausted oils, etc. bring damage to people or things or can cause negative effects to surroundings, health or safety respecting completely the laws and/or dispositions in force in the place.

The generating set GE 4500 is a unit which transforms the mechanical energy, generated by endothermic engine, into electric energy, through an alternator.

Is meant for industrial and professional use, powered by an endothermic engine; it is composed of various main parts such as: engine, alternator, electric and electronic controls, the fairing or a protective structure.

The assembling is made on a steel structure, on which are provided elastic support which must damp the vibrations and also eliminate sounds which would produce noise.

Technical data
GE 4500 HSX
GENERATOR

<i>Single-phase output max</i>	4 kVA (3.6 kW) / 230 V / 17.4 A (15.7 A)
<i>Single-phase output max</i>	4 kVA (3.6 kW) / 115 V / 34.8 A (31.3 A)
<i>Frequency</i>	50 Hz
<i>Cos φ</i>	0.8

ALTERNATOR

	self-excited, self-regulated, brushless
<i>Type</i>	synchronous, single-phase
<i>Insulating class</i>	H

ENGINE

<i>Mark</i>	HONDA
<i>Model</i>	GX 270
<i>Type</i>	4-Stroke
<i>Displacement</i>	270 cm ³
<i>Cylinders</i>	1
<i>Output max</i>	5.9 kW (8 HP)
<i>Speed</i>	3000 rpm
<i>Fuel consumption</i>	313 g/kWh
<i>Cooling system</i>	air
<i>Engine oil capacity</i>	1.1 l
<i>Starter</i>	electric
<i>Fuel</i>	gasoline

GENERAL SPECIFICATIONS

<i>Battery</i>	12V - 15 Ah
<i>Tank capacity</i>	13 l
<i>Running time (75%)</i>	7.5 h
<i>Protection</i>	IP 23
<i>Dimensions / max. Lxwxh (mm) *</i>	900x570x720 (230V version)
<i>Dimensions / max. Lxwxh (mm) *</i>	900x570x770 (230/115V version)
<i>Weight (dry) *</i>	130 Kg (230V version) - 132 Kg (230/115V version)
<i>Noise level</i>	88 LWA (63 dB(A) - 7 m)

* Dimensions and weight are inclusive of all parts.

OUTPUT

Declared powers at the following ambient conditions: temperature 20°C, relative humidity 30% altitude 100 m above sea level. In an **approximative** way one reduces: of 1% every 100 m altitude and of 2.5% for every 5°C above 25°C.

For possible modifications or changes to be brought on the engines, with climate conditions different from those above mentioned, please call our Assistance Authorized Centers.

ACOUSTIC POWER LEVEL

The machine respects the noise limits, expressed in sound power, given in the a.m. directives.

These limits can be used to judge the sound level produced on site.

For example: the sound power level of 100 LWA.

The sound pressure (noise produced) at 7 meters distance is about 75dBA (the limit value less 25).

To calculate the sound level at other distances use this formula:

$$dBA_x = dBA_y + 10 \log \frac{r_y^2}{r_x^2}$$

At 4 meters the noise level becomes:

$$75 \text{ dBA} + 10 \log \frac{7^2}{4^2} = 80 \text{ dBA}$$

**DIMENSIONI
DIMENSIONS**

**SCHEMI ELETTRICI
ELECTRICAL SYSTEM**

**RICAMBI
SPARE PARTS**

MOSA

© MOSA 1.0-06/04

Ⓜ Dimensioni
Ⓜ Dimensions
Ⓜ Dimensions

Ⓜ Abmessungen
Ⓜ Dimensiones
Ⓜ

GE 4500 HSX

M
53

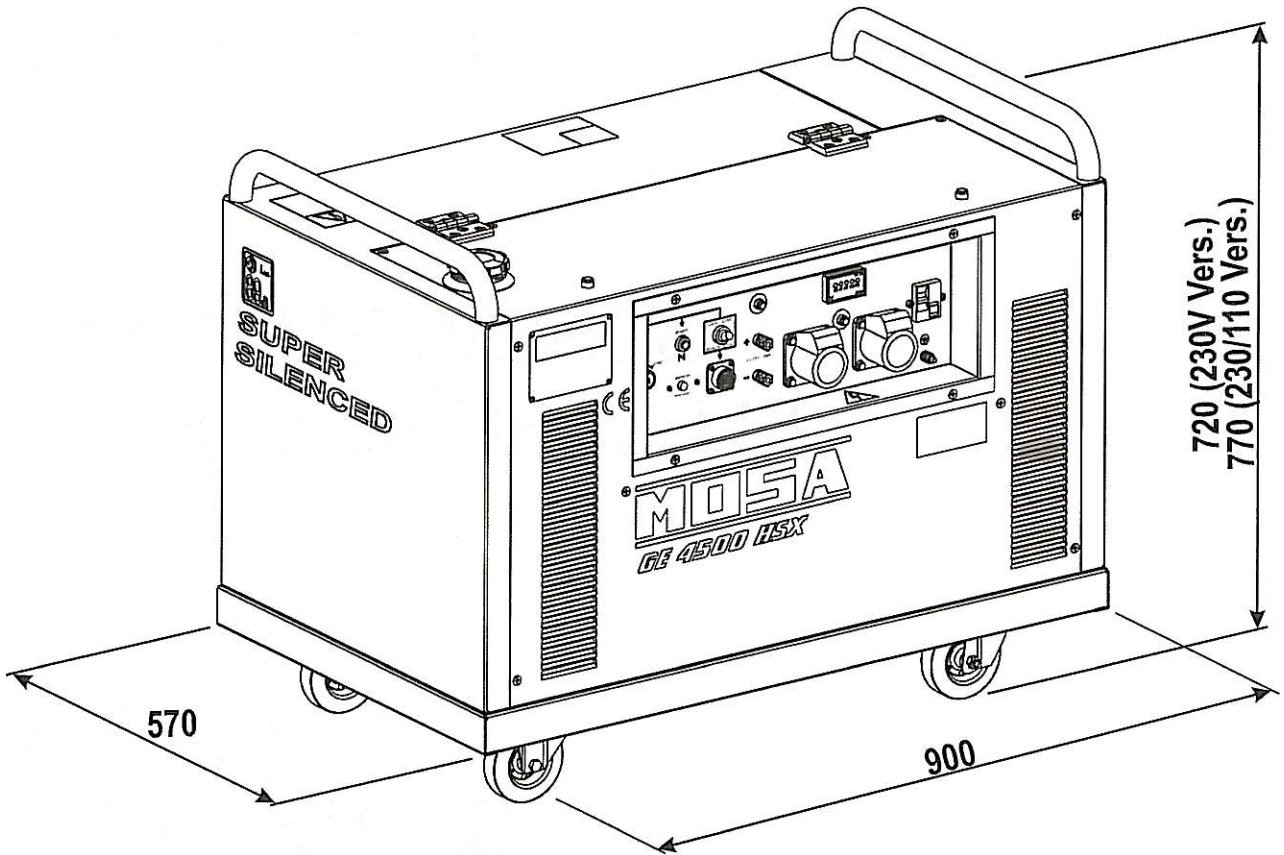

A : Alternatore
 B : Supporto connessione cavi
 C : Condensatore
 D : Interruttore differenziale
 F : Fusibile
 H : Presa 230V monofase
 I : Presa 110V monofase
 M : Contaore
 N : Voltmetro
 Q1 : Chiave avviamento
 R1 : Motorino avviamento
 S1 : Batteria
 T1 : Alternatore carica batteria
 S2 : Trasmettitore livello olio
 B3 : Connettore E.A.S.
 G3 : Bobina accensione
 H3 : Candela accensione
 M3 : Diodo carica batteria
 N3 : Relè
 N4 : Elettromagnete aria
 P4 : Protezione termica
 Q4 : Prese carica batteria
 Y5 : Commutatore Serie/Paralelo
 I6 : Selettore Start Local/Remote
 L6 : Pulsante CHOKE

A: Alternator
 B: Wire connection unit
 C: Capacitor
 D: G.F.I.
 F: Fuse
 H: 230V 1phase socket
 I: 110V 1phase socket
 M: Hour-counter
 N: Voltmeter
 Q1: Starter key
 R1: Starter motor
 S1: Battery
 T1: Battery charge alternator
 S2: Oil level transmitter
 B3: E.A.S. connector
 G3: Ignition coil
 H3: Spark plug
 M3: Battery charge diode
 N3: Relay
 N4: Choke solenoid
 P4: Circuit breaker
 Q4: Battery charge sockets
 Y5: Commutator/switch, series/parallel
 I6: Start Local/Remote selector
 L6: Choke button

A : Alternateur
 B : Connexion câbles
 C : Condensateurs
 D : Interrupteur différentiel
 F : Fusible
 H : Prise 230V monophasé
 I : Prise 110V monophasé
 M : Compte-heures
 N : Voltmètre
 Q1 : Clé de démarrage
 R1 : Moteur de démarrage
 S1 : Batterie
 T1 : Alternateur charge batterie
 S2 : Transmetteur niveau huile
 B3 : Connecteur E.A.S.
 G3 : Bobine allumage
 H3 : Bougie allumage
 M3 : Diode charge batterie
 N3 : Relais
 N4 : Electro-aimant air
 P4 : Protection thermique
 Q4 : Prises charge batterie
 Y5 : Commutateur Série/Parallèle
 I6 : Selecteur Start Local/Remote
 L6 : Bouton Choke

A Generator
 B Klemmleiste
 C Kondensatorbox
 D FI-Schalter (GFI)
 F Sicherung
 H Steckdose 230V 1-phasig
 I Steckdose 110V 1-phasig
 M Stundenzähler
 N Voltmeter
 Q1 Zündschloss
 R1 Anlasser
 S1 Batterie
 T1 Ladegenerator Batterie
 S2 Ölstandssensor
 B3 Steckdose EAS/Fernstart
 G3 Zündspule
 H3 Zündkerze
 M3 Diode Batterielader
 N3 Relais
 N4 Elektromagnet Motor-Choke
 P4 Thermosicherung
 Q4 Steckdose Batterielader
 Y5 Umschalter seriell/parallel
 I6 Umschalter Fernstart
 L6 Choke-Taste

A :Alternador
 B :Soporte conexión cables
 C :Condensador
 D :Interruptor diferencial
 F :Fusible
 H :Toma 230V monofásica
 I :Toma 110V monofásica
 M :Cuentahoras
 N :Voltímetro
 Q1 :Llave arranque
 R1 :Motor arranque
 S1 :Batería
 T1 :Alternador carga batería
 S2 :Captador nivel aceite
 B3 :Conector E.A.S.
 G3 :Bobina encendido
 H3 :Bujía encendido
 M3 :Diodo carga batería
 N3 :Relé
 N4 :Electromagnetismo aire
 P4 :Protección térmica
 Q4 :Tomas carga batería
 Y5 :Contactor Serie/Paralelo
 I6 :Selector Start Local/Remote
 L6 :Pulsador CHOKE (aire)

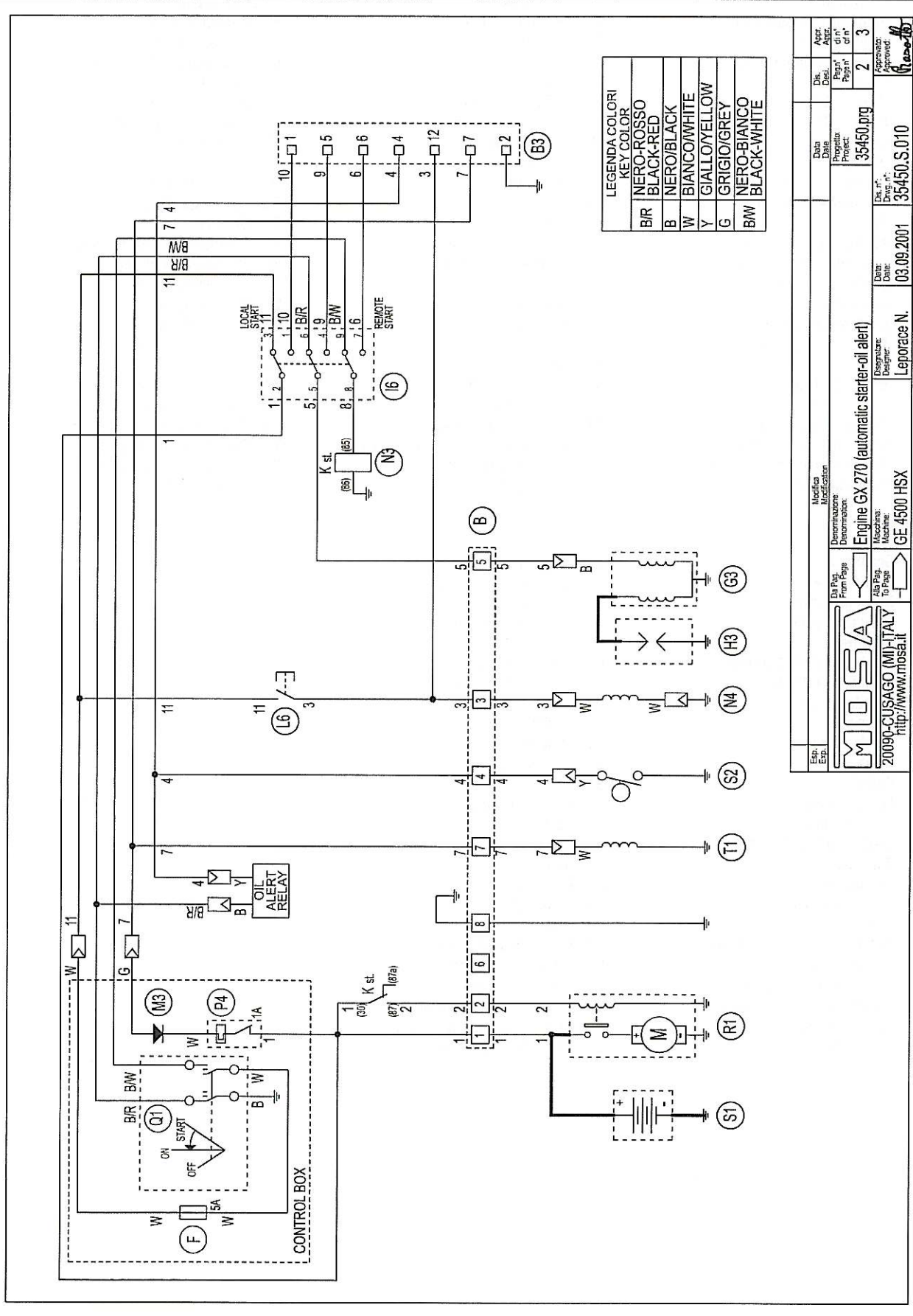

Dis. n°	35450.prg
Dis. n°	35450.S.010
Disegnato	Leporace N.
Disegnato	GE 4500 HSX
Disegnato	20090-CUSAGO (MI)-ITALY
Disegnato	http://www.mosa.it
Disegnato	Engine GX 270 (automatic starter-oil alert)
Disegnato	Macchine
Disegnato	GE 4500 HSX
Disegnato	20090-CUSAGO (MI)-ITALY
Disegnato	http://www.mosa.it
Disegnato	35450.prg
Disegnato	2
Disegnato	3
Disegnato	3

La MOSA si riserva a termini di legge la proprietà del presente disegno con divieto di riprodurlo o comunicarlo a terzi senza sua autorizzazione

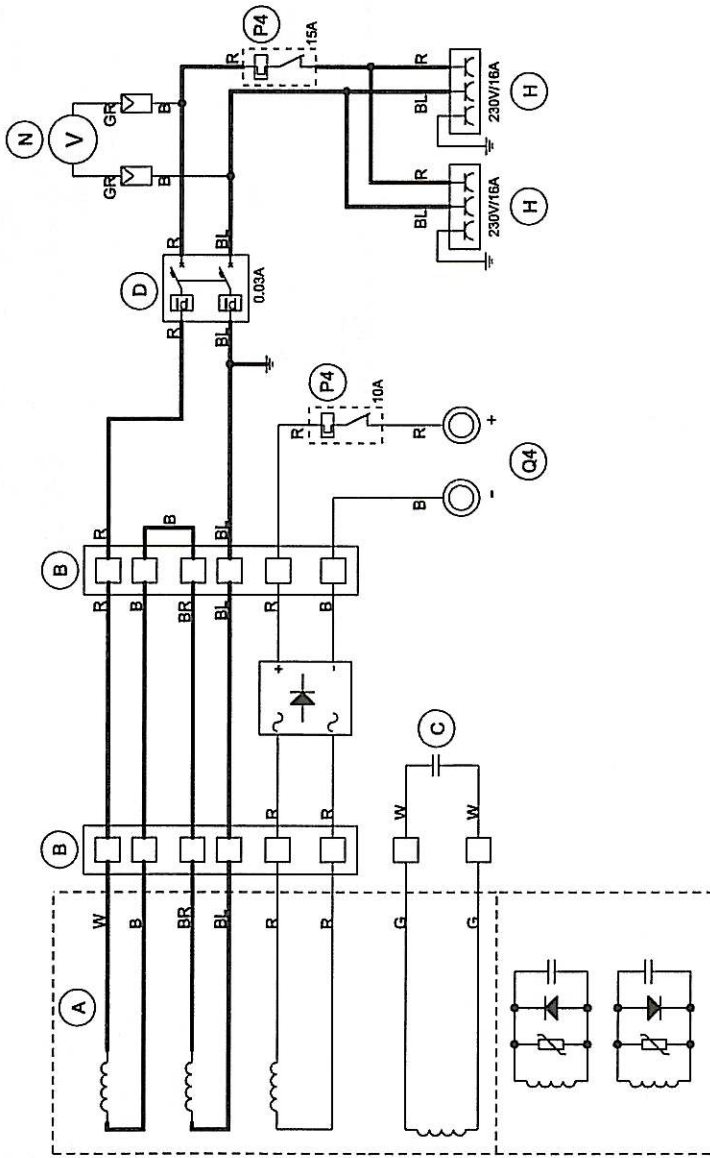

LEGENDA COLORI KEY COLOR	
R	ROSSO/RED
B	NERO/BLACK
BL	BLU/BLUE
BR	MARRONE/BROWN
W	BIANCO/WHITE
GR	VERDE/GREEN
G	GRIGIO/GREY

Exp. Esbl.	Modifica / Modification	Data / Date	Dis. / Dis.	Appr. / Appr.
	Da / From	Project	Page n° / Page n°	Page n° / Page n°
	Denominazione / Denomination:	35455.ptg	3	3
	Disegnatore / Designer:	35455.S.020		
	Macchine / Machines:	12.02.2004		
	GE 4500 HSX			
	Aux. (230Mx2/12Vdc) DT			
	Ala / To			
	20090-CUSAGO (MI)-ITALY			
	http://www.mosa.it			
	La MOSA si riserva ai termini di legge la proprietà del presente disegno con divieto di riproduzione o comunicazione a terzi senza sua autorizzazione.			

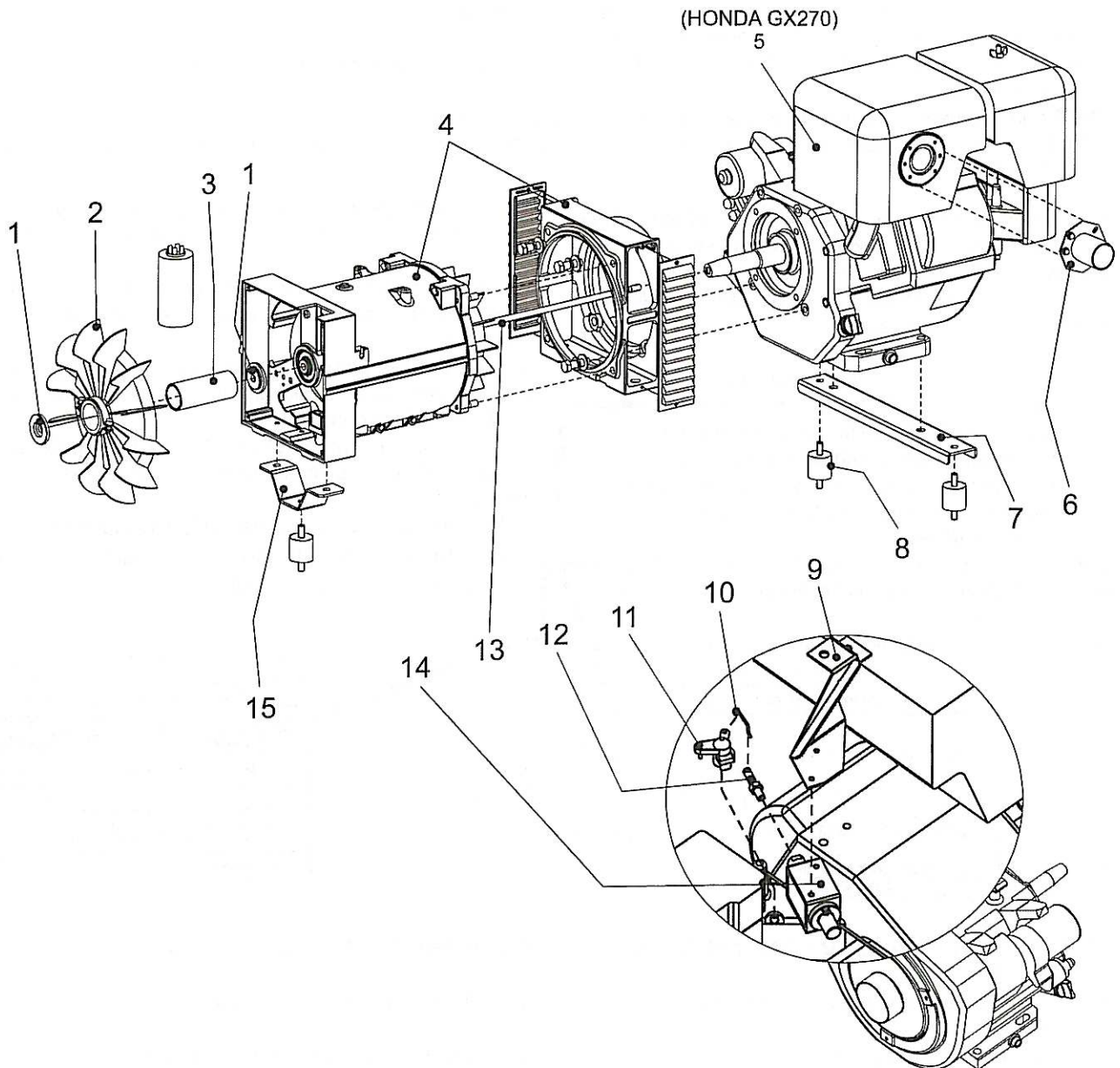



© MOSA 1.0-06/04

I Ricambi

GB Spare parts

F Pièces de rechange

D Ersatzteile

E Tabla de recambios

NL

GE 4500 HSX

GA
9.1

<i>Pos.</i>	<i>Rev. Cod.</i>	<i>Descr.</i>	<i>Note</i>
1	354553038	RONDELLA BLOCC. DISTANZ./VENTOLA	
2	105111290	VENTOLA CON FASCETTA	
3	354553039	DISTANZ. FISS. VENTOLA	
4	254003100	ALTERNATORE "SINCRO" ER2CAT4,2KVA-230V	
5	354502200	MOTORE HONDA GX270	
6	354502078	RACCORDO TUBO SCARICO	
7	254602035	TRAVERSA SUPP. MOTORE	
8	254601035	ANTIVIBTANTE D30x30	
9	306479101	STAFFA SUPPORTO SOLENOIDE	
10	306479056	TIRANTE PER ELETTROMAGNETE	
11	354509111	LEVA CHOKE	
12	306479108	PERNO ACCELERATORE	
13	354553036	TIRANTE	
14	306479071	ELETTROMAGNETE COMANDO CHOKE	
15	354553101	STAFFA SUPP. ALTERNATORE	

<i>Pos.</i>	<i>Rev. Cod.</i>	<i>Descr.</i>	<i>Note</i>
1	354553038	WASHER	
2	105111290	FAN	
3	354553039	FIXING FAN SPACER	
4	254003100	ALTERNATOR "SINCRO" ER2CAT4,2KVA-230V	
5	354502200	HONDA ENGINE GX270	
6	354502078	EXHAUST PIPE CONNECTOR	
7	254602035	ENGINE BRACKET	
8	254601035	VIBRATION DAMPER D30x30	
9	306479101	BRACKET ECONOMIZER HOLDER	
10	306479056	ROD FOR ELECTRO MAGNET	
11	354509111	CHOKE LEVER	
12	306479108	ACCELERATOR PIN	
13	354553036	CRANK SHAFT TIE-ROD	
14	306479071	ELECTRO MAGNET CHOKE CONTROL	
15	354553101	ALTERNATOR BRACKET	

230V VERSION

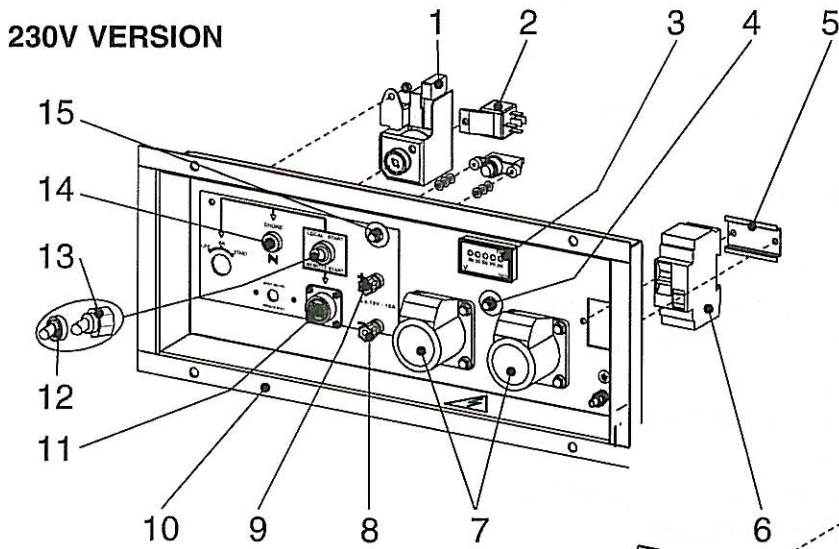

230/110V VERSION

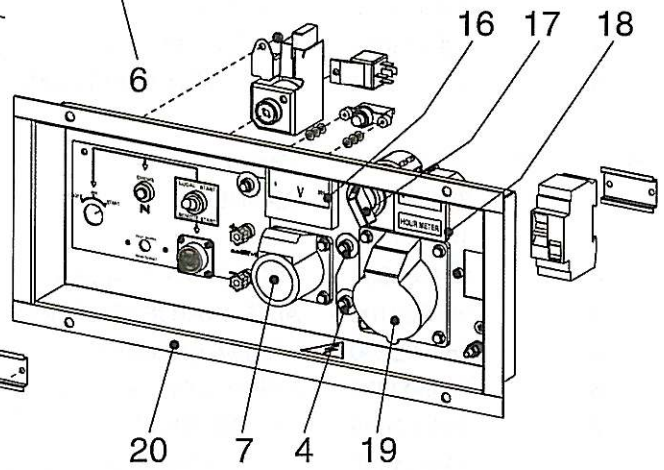

SCHUKO VERSION

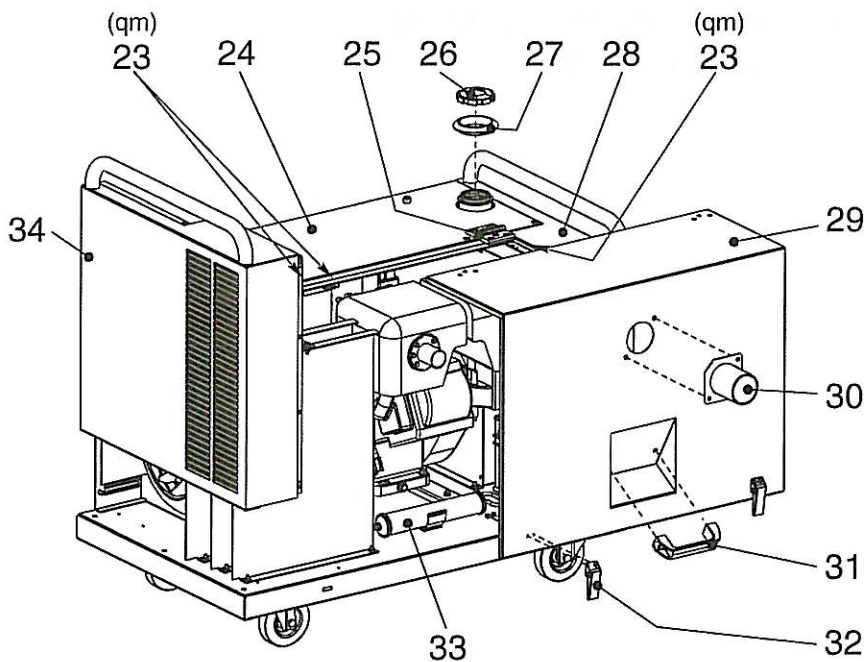
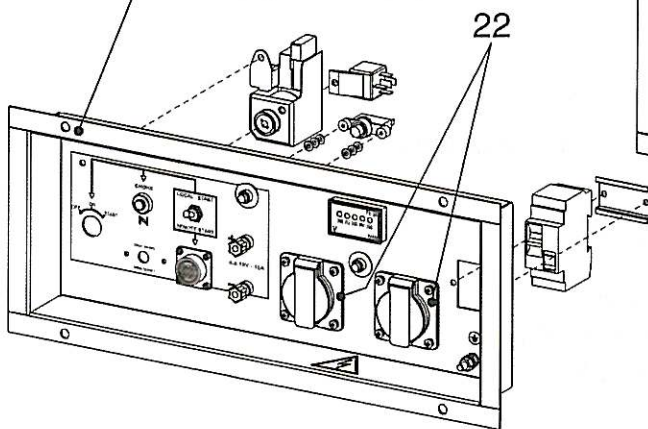

Pos.	Rev.	Cod.	Descr.	Note
1		35450A902	VARIANTE CAVI CHIAVE AVVIAMEN.	
2		306479199	RELE' AVV. ELETTRICO	
3		270027300	VOLTMETRO DIGITALE 30FE.001.OR	Vers. 230V
4		155307107	DISGIUNTORE TERMICO	Vers. 230V
5		306417036	GUIDA FISSAGGIO INTERRUETTORE	
6		220237105	Vedi Cod.256007105	
7		307017240	PRESA 220V 16A	
8		306417318	PRESA C.B. NERA (-)	
9		306417316	PRESA C.B. ROSSA (+)	
10		354507020	PANNELLO FRONTALE	Vers. 230V
11		35450C020	GR.CAVI MOTORE	x connettore EAS
12		102042740	CAPPUCCIO	
13		107509902	COMMUTATORE TRIPOLARE	
14		101091830	PULSANTE DI STOP	
15		306467109	PROTEZIONE TERMICA (C.B.)	
16		103011310	VOLTMETRO	Vers. 230/110V
17		256417315	COMMUTATORE DI LINEA 25A 2POLI	Vers. 230/110V
18		356317330	CONTAORE QUADRATO 110V 50Hz	Vers. 230/110V
19		105111530	PRESA CEE 32A 110V	Vers. 230/110V
20		354527020	PANNELLO FRONTALE	Vers. 230/110V
22		259107241	PRESA SCHUKO 16A 230V - 2P+T	Vers. Schuko
23		309509005	GUARNIZIONE	qm
24		354508010	PANNELLO LATO ASPIRAZIONE	
25		744508140	CERNIERA PER FIANCATA	
26		259102026	TAPPO SERBATOIO	(il tappo originale è fornito con motore)
27		354502022	GUARNIZ. TUBO RIEMP. SERBATOIO	
28		354508015	PANNELLO LATO MOTORE	
29		354508021	PORTELLO LATO SCARICO	
30		354508186	RACCORDO PROLUNGA x TUBO SCAR.	
31		343339601	MANIGLIA	
32		354508110	CHIUSURA A LEVA REGOLABILE	
33		354502310	SIRINGA SCARICO/CARICO OLIO	
34		354508020	PANNELLO LATO ALTERNATORE	
Pos.	Rev.	Cod.	Descr.	Note
1		35450A902	STARTING KEY CABLING	
2		306479199	RELAY, ELECTRIC START	
3		270027300	DIGITAL VOLTMETER 30FE.001.OR	Vers. 230V
4		155307107	THERMAL SWITCH	Vers. 230V
5		306417036	FIXING GUIDE INTERRUPTOR	
6		220237105	See Part n°256007105	
7		307017240	EEC SOCKET 16A, 220V 2P+T	
8		306417318	BLACK B.C. SOCKET (-)	
9		306417316	RED BATTERY CHARGER SOCKET (+)	
10		354507020	FRONTAL PANEL	Vers. 230V
11		35450C020	ENGINE CABLES	x connettore EAS
12		102042740	CAP	
13		107509902	TRIPOLARS SWITCH	
14		101091830	BUTTON, STOP	
15		306467109	THERMOPROTECTION (B.C.)	
16		103011310	VOLTMETER	Vers. 230/110V
17		256417315	COMMUTATOR SWITCH 25A 2POLES	Vers. 230/110V
18		356317330	HOURMETER 110V 50HZ	Vers. 230/110V
19		105111530	SOCKET, EEC, 32A 110V	Vers. 230/110V
20		354527020	FRONT PANEL	Vers. 230/110V
22		259107241	SOCKET SCHUKO 16A 230V 2P+T	Vers. Schuko
23		309509005	GASKET	qm
24		354508010	AIR INTAKE PANEL	
25		744508140	LATCH	
26		259102026	TANK CAP	(il tappo originale è fornito con motore)
27		354502022	GASKET	
28		354508015	COVER, ENGINE SIDE	
29		354508021	EXHAUST PANEL	
30		354508186	EXHAUST PIPE CONNECTOR	
31		343339601	KNOB	
32		354508110	ADJUSTABLE LOCK	
33		354502310	OIL FILLING	
34		354508020	PLATE ALTERNATOR SIDE	

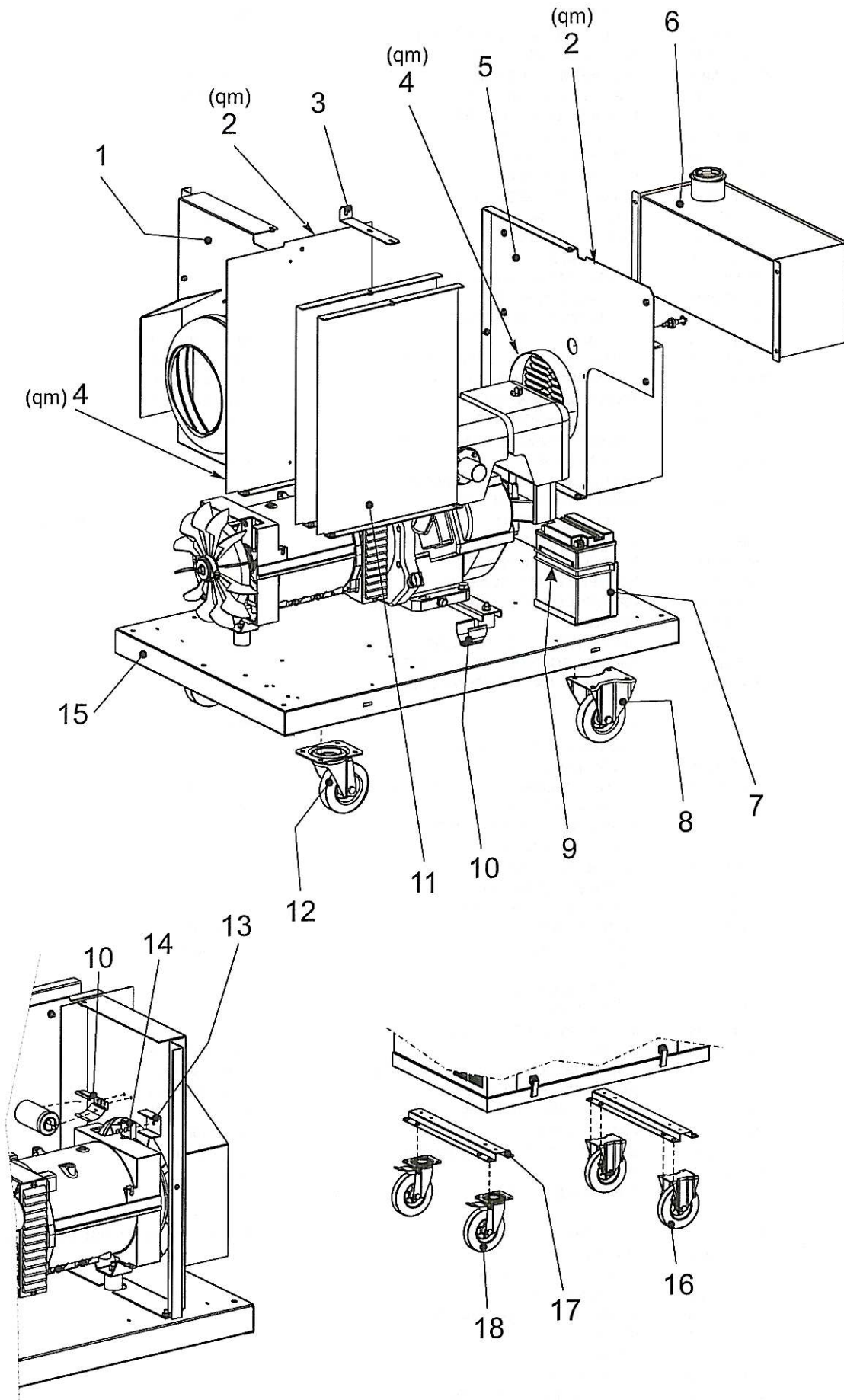

<i>Pos.</i>	<i>Rev. Cod.</i>	<i>Descr.</i>	<i>Note</i>
1	354558219	PARATIA ASPIRAZ. ALTERNATORE	
2	306418310	GUARNIZIONE (L=MT.1)	(qm)
3	354508066	SQUADRETTA FISS.SETTI INSONOR.	
4	102302280	GUARNIZIONE (L=MT.1)	(qm)
5	354508220	PARATIA ASPIRAZIONE MOTORE	
6	354502020	SERBATOIO CARBURANTE	
7	306469150	BATTERIA 60A	
8	354501170	RUOTA GOMMA PIENA SUPP. FISSO	
9	306469282	ELASTICO FISSAGGIO BATTERIA	
10	354507037	CLIP D36 L40	
11	354508067	PARATIA SETTO INSONORIZZANTE	
12	354501270	RUOTA GOMMA PIENA SUPP. GIREV.	
13	306225030	DISSIPATORE PER PONTE DIODI	
14	1270070	PONTE DIODI 120A	
15	354551050	BASAMENTO	
16	354521170	RUOTA GOMMA PIENA SUPP. FISSO	(230/110V Version)
17	354521099	TRAVERSA SUPP. RUOTE	(230/110V Version)
18	354521270	RUOTA GOMMA PIENA SUPP. GIREV.	(230/110V Version)

<i>Pos.</i>	<i>Rev. Cod.</i>	<i>Descr.</i>	<i>Note</i>
1	354558219	ALTERNATOR PANEL	
2	306418310	PROTECTION GASKET (L=MT.1)	(qm)
3	354508066	NOISE ELEMENT BRACKET	
4	102302280	GASKET (L=MT.1)	(qm)
5	354508220	ENGINE PANEL	
6	354502020	FUEL TANK	
7	306469150	BATTERY 60A	
8	354501170	WHEEL	
9	306469282	ELASTIC, FIXING BATTERY	
10	354507037	CLIP D36 L40	
11	354508067	NOISE PANEL	
12	354501270	MOVING WHEEL	
13	306225030	DIODE BRIDGE DISSIPATOR	
14	1270070	DIODE BRIDGE 120A	
15	354551050	BASE	
16	354521170	WHEEL	(230/110V Version)
17	354521099	WHEEL BRACKET	(230/110V Version)
18	354521270	MOVING WHEEL	

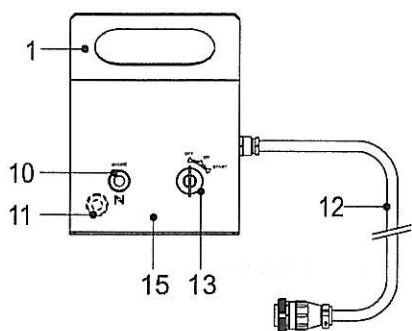
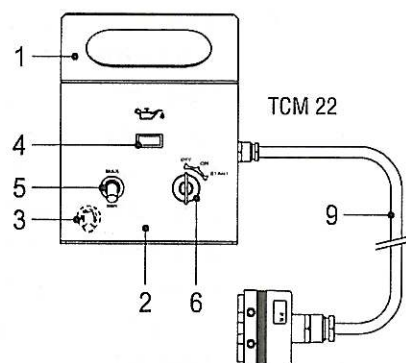
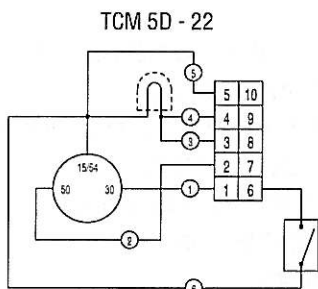
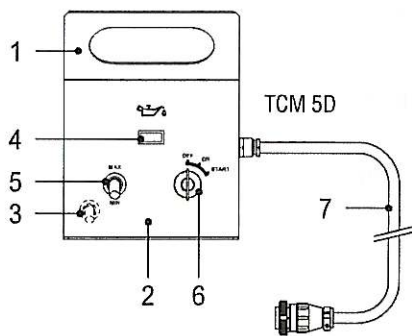

TCM 5

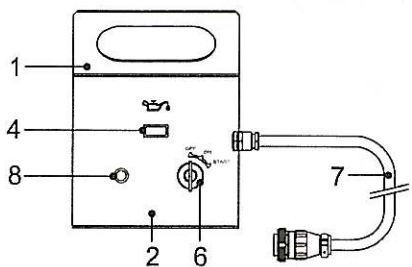
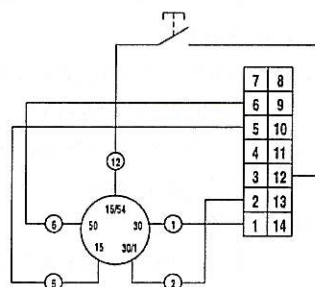

TCM 6

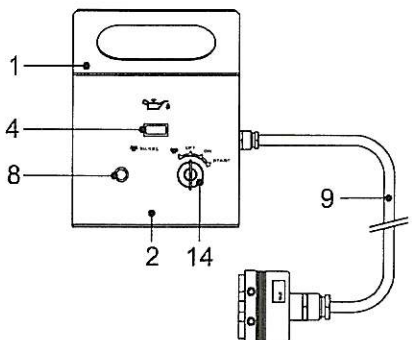
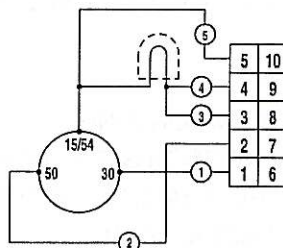

TCM 40

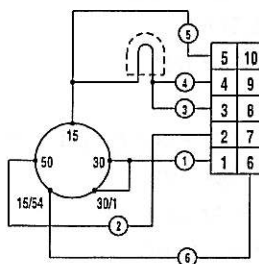

SCHEMA ELETTRICO
 ELECTRICAL DIAGRAM
 ELECTRIQUE SCHEMA
 ELEKTRISCHES SCHEMA
 ELECTRISCH GEDEELTE
 ESQUEMA ELÉCTRICO

Pos.	Rev.	Cod.	Descr.	Descr.	Note
1		107509900	SCATOLA	CASE, BOTTOM HALF	
2		330109901	COPERCHIO PER SCATOLA TCM	TCM COVER	
3		102042740	CAPPUCCIO	CAP	
4		1302040	SPIA 12V	WARNING LIGHT 12V	
5		102013290	COMMUTATORE	COMMUTATOR	
6		107302460	STARTER A CHIAVE	STARTER KEY	
7		33010C060	GRUPPO CAVI TC	TC CABLE KIT	TCM5D-6
8		6062050	TAPPO	CAP	
9		33020C060	GR.CAVI TCM	TCM CABLE KIT	TCM22-40
10	A	101091830	PULSANTE DI STOP	BUTTON, STOP	TCM5
11	A	101091840	CAPPUCCIO	CAP	TCM5
12	A	93015C060	GRUPPO CAVI TCM	TCM CABLE KIT	TCM5
13	A	259107055	STARTER A CHIAVE	KEY STARTER	TCM5
14	A	307457055	INTERRUTT.ACCESSIONE A CHIAVE	STARTER SWITCH	TCM40
15	A	930159901	COPERCHIO PER SCATOLA TCM	TCM COVER	TCM5

