

START HERE!

READ ME FIRST

Don't be a hero and muscle through this installation without reading these fitting instructions first! Improper installation of this gear may void certain aspects of your warranty.

Before you begin, take a moment and open all your Front Runner rack kit boxes and gather the assembly instructions for the various components.

A complete kit will contain:

1. A Front Runner Mounting System specific to your vehicle
2. A Front Runner Rack Tray or Load Bar Slats

This document will guide you through the assembly of the mounting system and assist you in fitting the roof rack tray or load bars to your specific vehicle.

Please refer to the next page for a list of all the components, quantities and tools required.

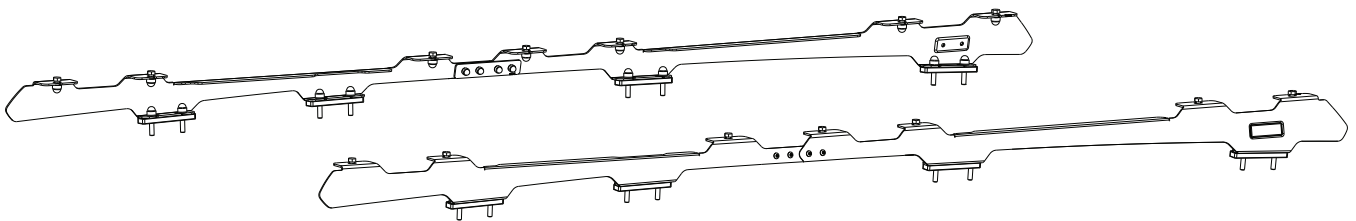

IMPORTANT WARNING!

IT IS CRITICAL THAT ALL FRONT RUNNER PRODUCTS BE PROPERLY AND SECURELY ASSEMBLED AND ATTACHED TO YOUR VEHICLE. IMPROPER ATTACHMENT COULD RESULT IN AN AUTOMOBILE ACCIDENT, AND COULD CAUSE SERIOUS BODILY INJURY OR DEATH. YOU ARE RESPONSIBLE FOR ASSEMBLING AND SECURING ALL FRONT RUNNER PRODUCTS TO YOUR VEHICLE, CHECKING THE ATTACHMENTS PRIOR TO USE, AND PERIODICALLY INSPECTING THE PRODUCTS FOR ADJUSTMENT, WEAR AND DAMAGE. THEREFORE, YOU MUST READ AND UNDERSTAND ALL OF THE INSTRUCTIONS AND PRECAUTIONS SUPPLIED WITH YOUR FRONT RUNNER PRODUCT PRIOR TO INSTALLATION OR USE. IF YOU DO NOT UNDERSTAND ALL OF THE INSTRUCTIONS AND CAUTIONS, OR IF YOU HAVE NO MECHANICAL EXPERIENCE AND ARE NOT THOROUGHLY FAMILIAR WITH THE INSTALLATION PROCEDURES, YOU SHOULD HAVE THE PRODUCT INSTALLED BY A PROFESSIONAL INSTALLER OR OTHER QUALIFIED PERSONNEL.

NOTE: Front Runner will not be responsible for any damage caused by the failure to install the product according to these instructions.

Please call us if you have any questions about the installation of this product.

1

GET ORGANIZED

IN THE BOX

1	2 X	Front Foot Rail 1LH+1RH
2	28 X	M8 Flat Washer
3	16 X	M8 Spring Washer
4	16 X	M8 x 40 Hex Head Bolt
5	28 X	M8 Nut Cap
6	8 X	M6 x 16 Button Head Screw
7	2 X	Rear Foot Rail 1LH+1RH
8	12 X	M8 x 20 Hex Head Bolt
9	12 X	M8 Nyloc Nut
10	8 X	Spacer
11	2 X	Joiner Plate
12	8 X	M6 Flat Washer
13	8 X	M6 Nyloc Nut
14	8 X	M6 Nut Cap

TOOLS NEEDED

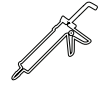
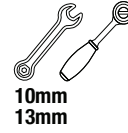
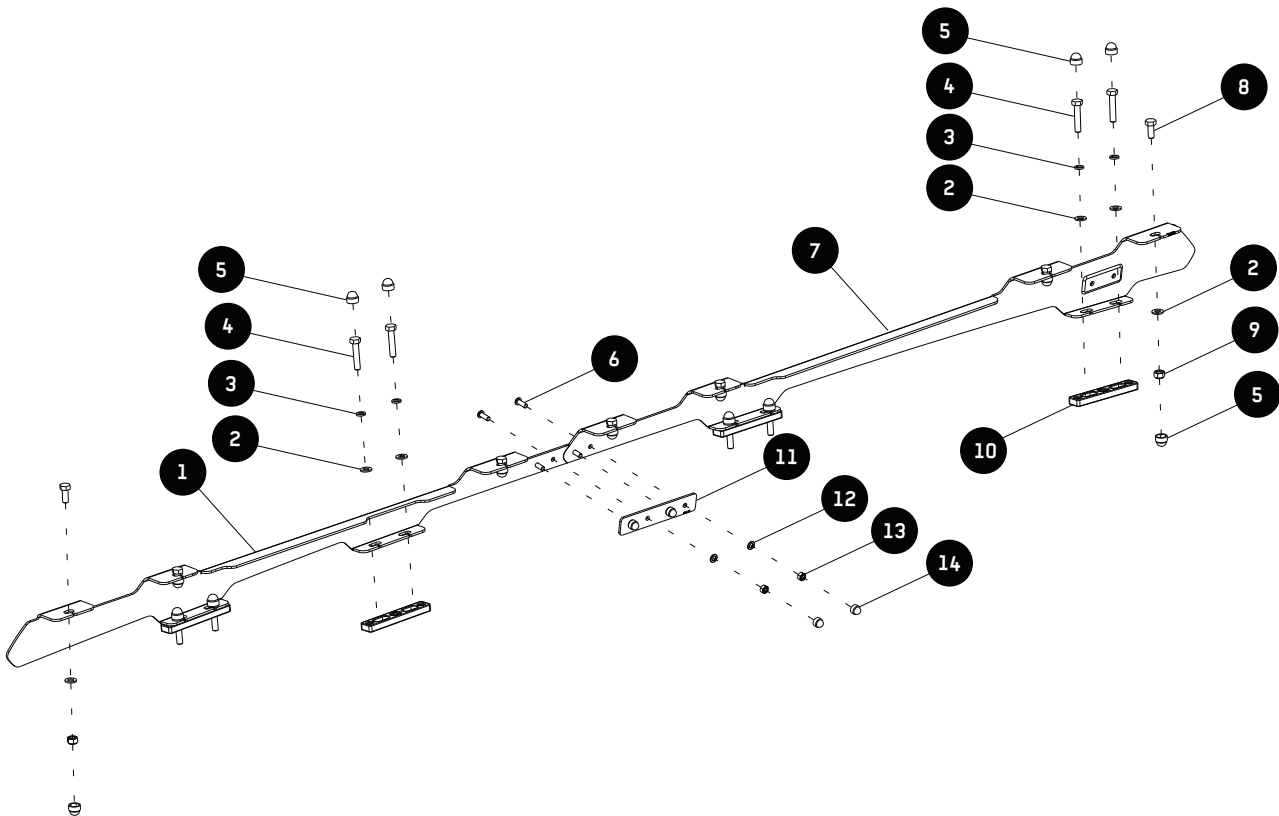
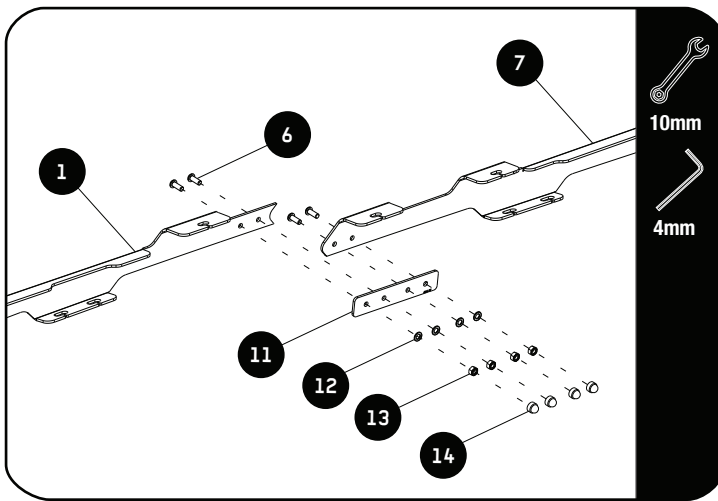

FIGURE 1.1



2.1



Assemble the RH Front Foot Rail (Item 1) and the RH Rear Foot Rail (Item 7) using one Joiner Plate (Item 11), four M6x16 Button Head Screws, four M6 Flat Washers and four M6 Nyloc Nuts (Item 6, 12 & 13). Do this with the LH Front and Rear Foot Rails. Finish off by placing M6 Nut Caps (Item 14) over the M6 Nyloc Nuts.

2.2

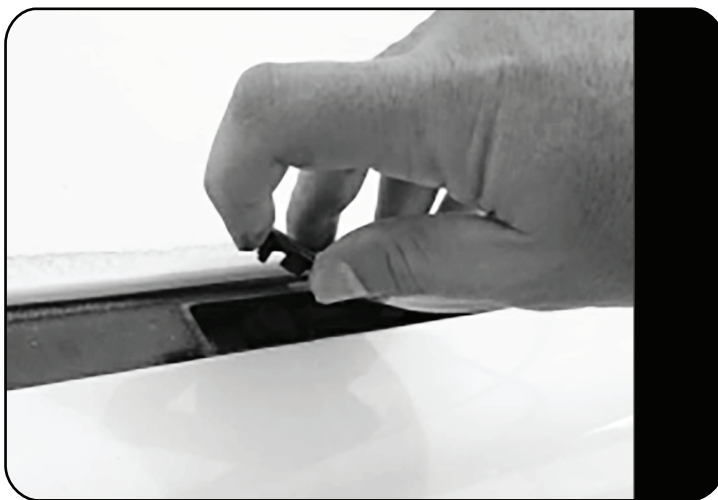

Locate and remove the eight plastic covers in the ditch moulding. Remove the two bolts and steel bracket below each plastic cover removed.

2.3



Use De-natured Alcohol to clean the surrounding areas of each bolt hole. Place a bead of silicone around each hole. Place the eight Spacers (Item 10) over each pair of holes.

2**FIT AND SECURE**

2.1

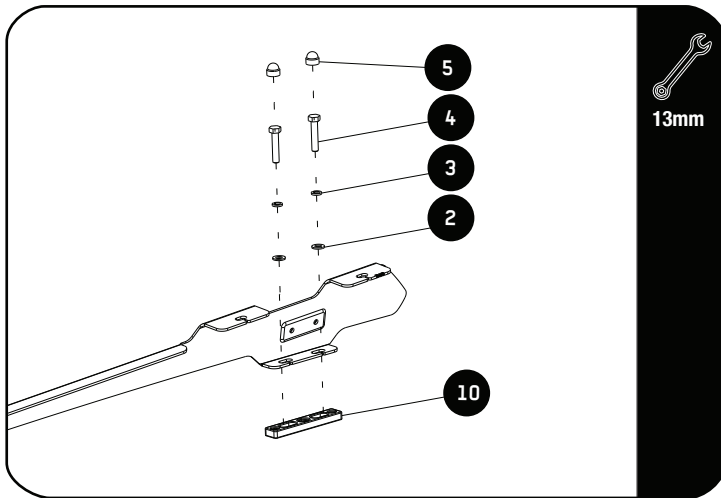

Place the assembled Foot Rails on top of the Spacers (Item 10). Apply silicone on the threads of the M8x40 Hex Bolts (Item 4) and secure the Foot Rail using M8 Spring Washers and M8 Flat Washers (Items 3 & 2).

Do this on both the left and right side of the vehicle.

Finish off by placing M8 Nut Caps (Item 5) over the M8 Hex Bolt heads.

To fit the Rack, proceed to Step 3.

3**FIT AND SECURE**

3.1

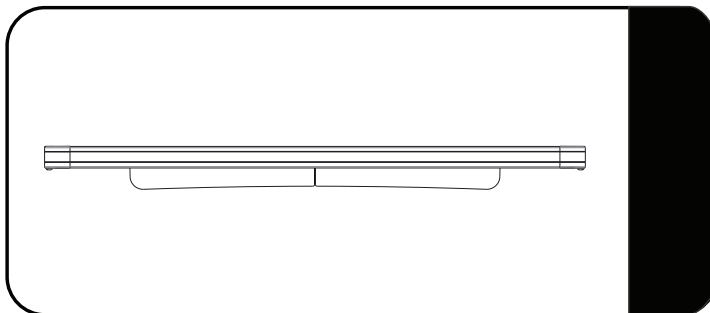

Make sure that the wind deflector is installed before you proceed to the next step.

3.2

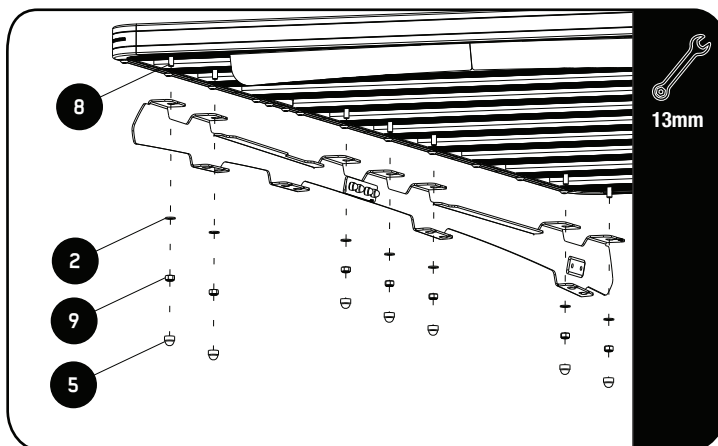

Fit your roof rack to the Foot Rails using M8x20 Hex Bolts, M8 Flat Washers and M8 Nyloc Nuts (Items 8, 2 & 9) as shown.

3

FIT AND SECURE

3.3

Center the rack and tighten fully. Use M8 nut caps (Item 5) to finish off the nuts.



4

INSTALL OTHER VEHICLE AND RACK ACCESSORIES

Now's the time to visit your favorite Front Runner Dealer in person or online.

IMPORTANT!

FRONT RUNNER RACK KITS OFTEN HAVE A HIGHER LOAD RATING THAN THE VEHICLES THEY ARE MOUNTED TO. PLEASE REFER TO YOUR SPECIFIC VEHICLE MANUFACTURER FOR A RECOMMENDED ROOF RATING. FRONT RUNNER CANNOT BE RESPONSIBLE FOR IMPROPER LOADING BEYOND THE VEHICLE MANUFACTURER'S STATED LOAD CAPACITY.

Be sure to tag us. We love to see our gear in action! #FrontRunnerOutfitters #BornToRoam

Share your adventures on: 