

2017 / 2018

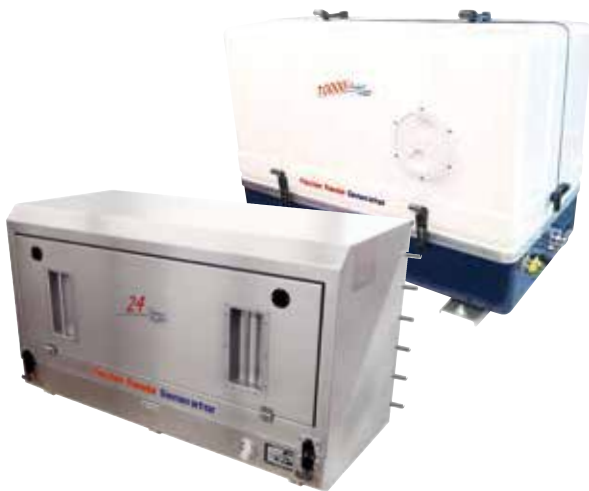

Fischer Panda Vehicle Generators



Fischer Panda[®]

Power wherever you are[™]



compact



light



quiet



Fischer Panda vehicle generators

- Compact
- Light
- Extremely quiet
- Water-cooled
- High performance
- Worldwide service network

The water-cooled diesel generators from Fischer Panda are renowned worldwide for being innovative, reliable and extremely quiet. The product range includes more than two hundred generators from 2.5 kW to 200 kW.

Fischer Panda generators feature an effective water-cooling system and a lightweight compact construction. This has made Fischer Panda a leader in Europe for mobile super-silent diesel generators. These highly proven generators supply power to electrical systems, drives and complete mobile energy systems.

Fischer Panda manufactures compact and quiet diesel generators for marine and vehicle applications. These are sold in more than eighty countries worldwide.

The company, based in Paderborn/Germany, was founded in 1977 under the name Icemaster GmbH and renamed as Fischer Panda GmbH in 2007.





Image courtesy: MOST Mobile Specials GmbH

Fischer Panda for mobile and stationary applications

Designed for use in special and diverse areas of the vehicle industry, Fischer Panda generators are installed in the smallest and tightest places available and can be found in numerous mobile applications worldwide.

Touring

- Luxury motor coaches
- Limousine coaches
- Holiday homes

Promotion

- Mobile stages
- Trade show vehicles
- Formula 1 team vehicles

Communications

- Mobile broadcasting
- Relay and transmitter sites
- Commercial vehicles

Emergency services

- Command centres
- Border control & customs
- Mobile blood donor units

Specialist services

- Environmental monitoring
- Railway & track maintenance
- Tactical shelters

Recreational

- Motorized RVs
- Expedition vehicles
- Off-grid and remote sites





Compact, quiet vehicle generators from Fischer Panda

Super-silent sound insulation system

The most significant advantage of all Fischer Panda generators is the low sound level. Many parts are required to work together to achieve this result. A flow of cooling air is not required inside the capsule, this also helps maintain constant ambient temperatures. An efficient water-cooling system requires the radiator to be installed separately from the generator.

Fischer Panda generators up to 25 kW are housed in a fibreglass (GFK) sound insulation capsule with "3D" sound insulation material as standard.

From 30 kW, the generator is housed in a stainless steel capsule (MPL). Depending on the size of the generator, the MPL sound-insulation capsule consists of 6 to 11 parts. MPL capsules are also available (at an additional cost) for generators from 6 kW to 25 kW.

Various versions of sound insulation material are available:

- 3D: 3 layers, up to 25 mm thick
- 4DS: up to 5 layers, up to 40 mm thick
- 6DS: up to 6 layers, up to 60 mm thick

Water-cooled exhaust silencer

PVMV-N, PVK-U and PVK-UK generators (up to 25 kW) are fitted with an internal water-cooled exhaust silencer.

- Less space required for installation
- Water-cooled AC winding
- Can be installed in tight spaces
- Hermetically sealed capsule
- All connections pre-fitted on capsule
- Modular design ensures installation flexibility
- No appreciable warming of the installation area
- Super-silent sound insulation system
- Water-cooled silencer (up to 25 kW)
- No cooling air circulating within capsule

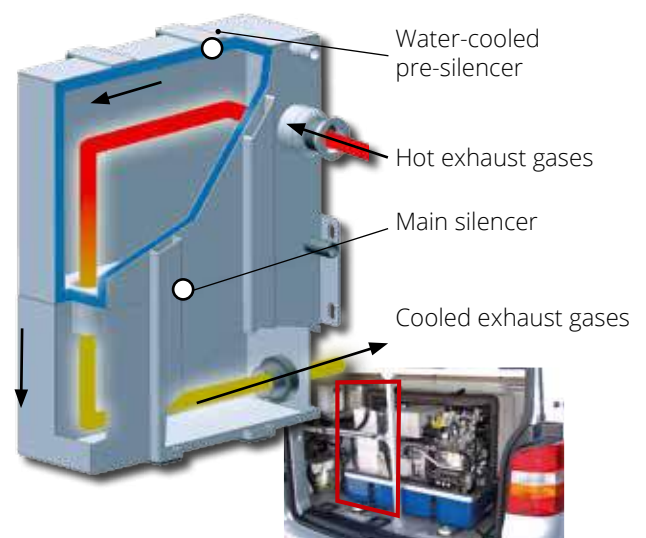

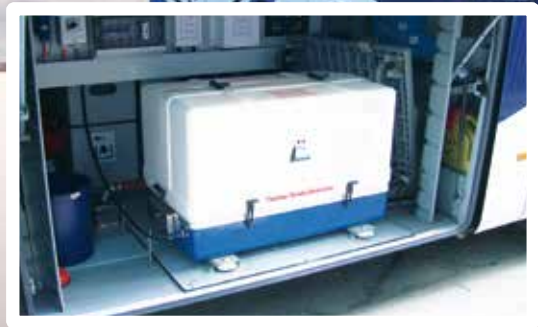

Vehicle installation: roof-mounted radiator

The radiator must be installed where good access for fresh air circulation is guaranteed. The best location is horizontally on the roof of the vehicle. The radiator has an integrated expansion tank.

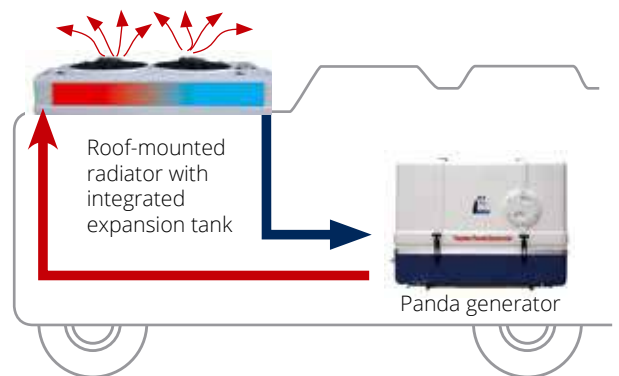

Vehicle installation: vertically mounted radiator

A radiator can be fitted vertically on the vehicle when there is no space on the roof.

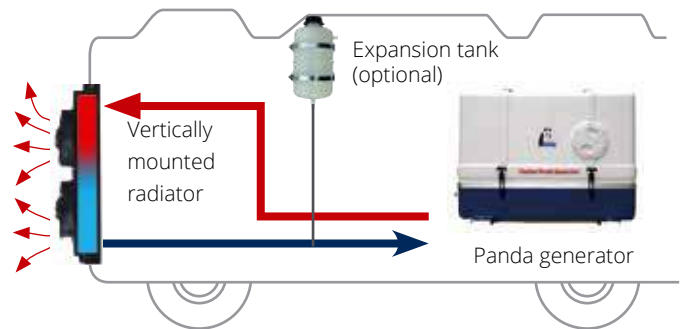

Vehicle installation: chassis-mounted

When sufficient clearance is available, the radiator may be mounted under the chassis. The air must be able to circulate correctly so warm air does not flow back over the radiator.

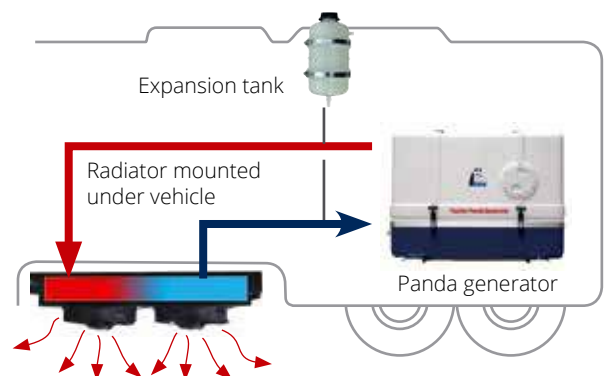



High performance AC windings from Fischer Panda

Single-phase windings

The 230 V 50 Hz, (120/240 V 60 Hz) single phase windings are standard for generators up to 25 kW. A three-phase version should be considered above 12 kW, as the Panda generator permits asymmetrical loads up to 50 % per phase. A Hybrid Power System should also be taken into consideration for small to middle range on-board power systems.

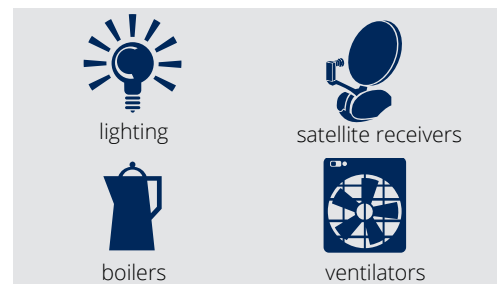

Three-phase windings

The 400 V AC 50 Hz, (208 V 60 Hz) three-phase winding has the highest level of efficiency and the best qualities. This winding can also supply single-phase AC with the appropriate phase distribution. A three-phase generator should always be chosen above 25 kW (from Panda 30).

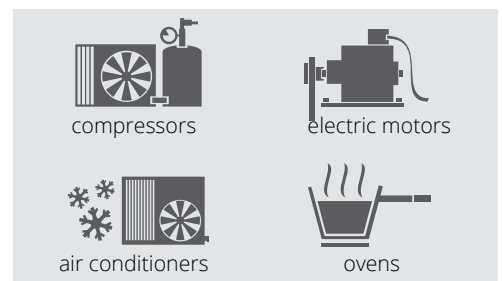

1-phase plus 3-phase (Panda "DVS" Dual Voltage System) winding

The "DVS" is a special version consisting of both a single-phase and a 400 V three-phase winding. **This version is only available from Fischer Panda** and without additional cost. Three-phase motors such as compressors can be used and a separate single-phase winding can supply the full nominal performance of the generator without "asymmetrical load problems" on a phase. This simplifies the electrical installation.

Note: Generators with DVS windings supply only 85% of the nominal performance compared to those with just a single or three-phase winding.

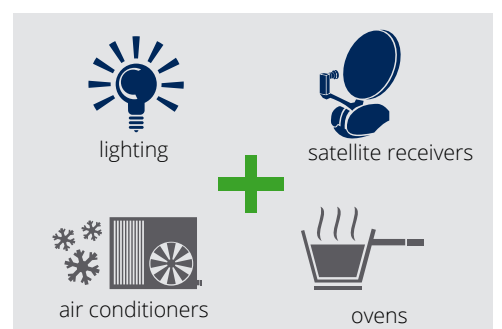

Fischer Panda iSeries generators - the next generation of compact, super-silent and powerful generators.

Perfect Power

Generators with variable speed technology

The Panda iSeries generators have been especially designed to be compact, quiet and powerful - with up to 30% weight and space savings! They are ideal for superyacht owners looking for a night generator with low operating sound levels and vibrations. The iSeries generators are characterised by their modern, innovative and environmentally friendly inverter technology. A parallel connection without additional cables is possible using special inverters.

The speed of the diesel engine is adjusted according to the user's changing power requirements while the output voltage always remains constant from the inverter. Variable speed control considerably reduces exhaust emissions and fuel consumption in comparison with a traditional generator with a fixed speed. The maximum speed of the engine is 2800 rpm. The electric load is provided with a constant output voltage of 230 V / 50 Hz or 400 V / 50 Hz via an inverter.

- Highly efficient - maximum energy
- Variable speed - load-dependent
- Meets latest emission standards
- Modular design ensures installation flexibility
- Extremely stable voltage and frequency
- High starting capacity for air-conditioners



Premium (and HD) Line: Fischer Panda generators with VCS Voltage Control and xControl

The Panda Premium Line generators have been fitted with the tried and tested VCS (Voltage Control System) for many years. The engine speed is progressively controlled and the generator can achieve up to 15 % more effective performance than a non-regulated generator. The VCS adjusts the voltage with a tolerance of ± 3 V in the range up to 80 % of the nominal performance. Controlling the speed also has a positive effect on exhaust emissions. The VCS and capacitors, used for boosting the starting current, are usually fitted inside an external AC control box.

Reliable and durable

The asynchronous generator delivers high standards regarding both operational security and life. Therefore, the asynchronous generator is often the preferred choice when a high degree of safety and reliability is demanded.

Fischer Panda warrants the rotor, often the most sensitive part of other generator systems, with a lifetime guarantee. Furthermore, the asynchronous generator continues to be the best suited for water-cooling as the copper winding is the only component producing heat via the stator. The electrical generator is warranted with a 5-year guarantee against corrosion.

Compact Power



xControl Panel for "Compact Power" xSeries generators

All the benefits of the asynchronous generator:

- Overload protection
- Water-cooled
- Short-circuit stability
- Highest operating protection
- High protection rating
- Brushless
- Perfect sine wave
- No rotating coils
- No diodes
- Precise control
- No signal noise
- Highly efficient

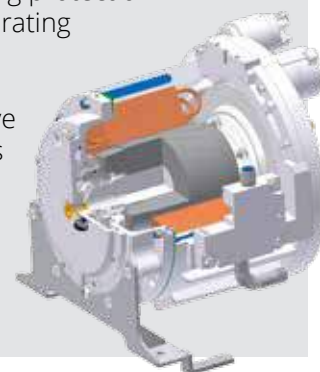



Fischer Panda Panels for ease of use and operation

Fischer Panda panels allow the generator to be operated from another location within the vehicle. Options are available for connecting panels in parallel or with a slave panel. The generator can then be operated from two locations for even more flexibility. A panel can be installed in the cabin and another panel can be fitted in the installation area. Important operating information is also displayed.



"AGT Panel" for "Hybrid Power" DC generators



"Panda iControl" panel for "Perfect Power" iSeries generators



"Panda xControl" panel for "Compact Power" xSeries generators

The standard version remote control panel (for models Panda over 30 kW and above) monitors the following functions:

- Engine coolant temperature
- Engine exhaust temperature
- Engine oil pressure
- Battery charging
- 230 Volt AC
- Cooling-water leakage (optional)

The generator switches itself off when any of these functions are not in the normal state. The standard remote control panel can be upgraded with an additional automatic module to enable the generator to be started (and stopped) by external devices such as timers.



"Generator Control" - standard panel for „Compact Power“ generators > 30 kW

Fischer Panda generators with innovative control

Innovative, flexible and reliable – these are the attributes of the new generator control from Fischer Panda for „Perfect Power“ iSeries generators and „Compact Power“ xSeries generators up to 30 kW.

In the age of modern data communications and energy systems, it is more and more important that the generator is able to integrate into an existing control and regulation systems. Fischer Panda offers an extremely powerful and user-friendly generator control system:

- “Plug & Play” - reduced installation effort
- Modular system - easy to expand
- Logging and display of operational data - complete control at all times
- Comprehensive event logging - long-term service
- Digital panel - easy to use and multilingual
- Communications interface - integration in other control systems
- Self-test of all functions - safe and reliable system
- Automatic start - remote control of generator
- Optional CAN SAE J1939

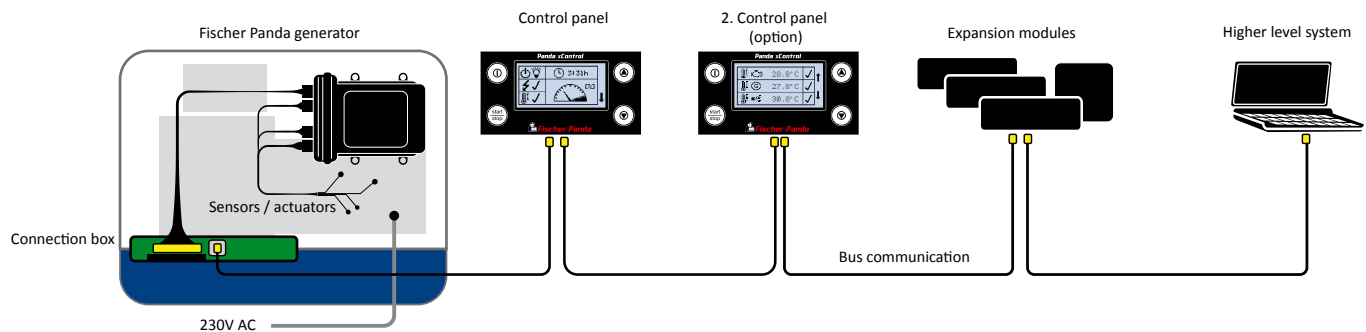

Perfect sine wave

Fischer Panda generators combine all the advantages of the asynchronous generator with the voltage control of a synchronous generator. Asynchronous Panda generators supply a particularly clean sine wave which is essential for the smooth running of sensitive electronic devices such as air conditioners, charging devices, laser printers, etc. Generators in this category have achieved exceptional results in numerous tests.

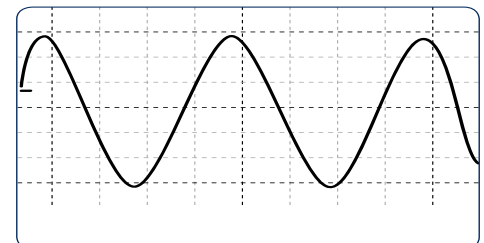

The outstanding sine wave of the Fischer Panda generator

Voltage stability with patented Voltage Control System

For more than ten years, Fischer Panda generators have used the patented electronic Voltage Control System (VCS) for controlling the generator and engine. The engine speed is progressively controlled and the output voltage of the asynchronous generator is within a tolerance of ± 3 V.

The patented Voltage Control System (VCS) from Fischer Panda

Generator Signal Interface

The Generator Signal Interface (GSI) enables the generator to be connected into a power management and control network. Other devices such as programmable logic controllers (PLCs) can then be used to control and monitor the generator remotely. The potential-free contacts enable external applications to access the status signals from the generator. External applications can also start and stop the generator.



Generator Signal Interface (GSI) for Fischer Panda generators

Professional solutions from Fischer Panda

Generators for all types of commercial and recreational vehicle applications

Different types of generators are available to provide you with an ideal power solution for your vehicle:

Hybrid AC energy



Fischer Panda battery charging generators produce direct current and generally function as part of a Hybrid Power System. Battery levels are monitored and automatically charged by the generator. An inverter supplies energy to the 230 V consumers on-board. These systems are ideal for varying power demands, and do not require a generator to constantly run throughout the day.

Suited for typical power applications requiring continuous power and higher starting capabilities

Compact Power

Hybrid Power: Powerful battery-charging generators. Ideal for battery systems which may be required to power larger consumers for short periods during the day

Hybrid Power

DC generators



Panda **AGT-DC Hybrid** vehicle battery charging generators

12 V / 24 V / 48 V)
(other voltages on request)



Battery
12 V / 24 V / 48 V DC



Inverter

Battery-powered systems



12 V / 24 V / 48 V DC



Panda **Premium Line** asynchronous vehicle generators with voltage control

Voltage tolerance ± 3 V

3000 rpm - 50 Hz - 230 V
3000 rpm - 50 Hz - 400 V
3600 rpm - 60 Hz - 120 / 240 V
3600 rpm - 60 Hz - 208 V AC



- Longer lifespan for generator
- Reduced maintenance costs
- Reduced environmental impact

- Reduced exhaust emissions
- Reduced fuel consumption
- Less noise on board & outside

- Longer battery life
- Smaller battery bank possible
- Up to 30 % smaller and lighter
- Automatic start as standard (optional manual start)

Advanced Generator Technology (AGT) only from Fischer Panda

AC energy direct

Fischer Panda AC generators are designed for continuous operation. They produce alternating current directly while running. Not only for operating domestic electrical appliances and electric cooking, they are the right choice for operating demanding consumers such as air-conditioning and compressors. They also produce a very clean sine wave, ideal for sensitive electronic equipment.



Suited for applications requiring continuous power and high starting capabilities with a very stable voltage supply

Compact Power

Suited for heavier commercial applications with long life spans

Compact Power

Generators with variable speed for lower fuel consumption, quieter operation and reduced exhaust emissions

Perfect Power

Asynchronous generators



Panda xSeries **Premium Line** asynchronous vehicle generators with voltage control

Voltage tolerance ± 3 V

3000 rpm - 50 Hz - 230 V
3000 rpm - 50 Hz - 400 V



Panda **1500/1800 rpm Series** asynchronous vehicle generators with voltage control

Voltage tolerance ± 3 V

1500 rpm - 50 Hz - 230 V
1500 rpm - 50 Hz - 400 V
1800 rpm - 60 Hz - 120 / 240 V
1800 rpm - 60 Hz - 208 V AC



Panda **iSeries** vehicle generators with variable speed technology

Voltage tolerance ± 3 V

50 Hz - 230 V
50 Hz - 400 V
60 Hz - 120 / 240 V (up to 15000i)
60 Hz - 230 V
variable speed - load dependent

Power for domestic electrical consumers



230 V / (120 / 240 V) AC

Fischer Panda generators are available in different versions to suit your individual requirements

Fischer Panda generators are of compact construction and highly suited for applications with limited space available. They are available for installation inside the vehicle and for mounting externally on the chassis. The modular versions PVMV-N, PVM-NE and PVK-U have been designed to be installed with an external radiator. The most effective cooling is usually achieved using a cooling system with a roof-mounted radiator.

Complete programme

Panda PVM-NE

The PVM-NE is the standard version for generators above 30 kW. The PVM-NE is similar to the PVMV-N, however the silencer is not water-cooled and is externally mounted on the capsule.

The generator must be installed in a well-ventilated area because heat is absorbed by the silencer. An additional silencer is not necessary. The generator is housed within a sound insulation capsule.



- Suitable for internal installation
- Requires external radiator
- Easy to install

Panda PVMV-N

Vehicle generator with sound insulation capsule, integrated water-cooled vertically mounted pre-silencer and main silencer.



- Easy to install
- Requires external radiator
- Suitable for keel cooling in ships
- Suitable for internal installation
- Best choice, when space is available inside the vehicle
- Complete water-cooled silencer inside capsule
- Glass-reinforced plastic (GRP) capsule standard for models up to 12 kW
- Stainless steel capsule (MPL) for models from 15 kW and above

Panda PVK-U

Vehicle generators with internal water-cooled silencer for mounting externally on the vehicle chassis.

This generator type is ideal for installing on trucks with limited space between axles. The heavy-duty housing is also suitable for expedition vehicles.



- Designed for external mounting
- Assembly bolts pre-fitted to housing
- Metal capsule with a heavy-duty cover
- Wide access hatch for easier access
- Water-cooled exhaust silencer inside capsule
- No additional exhaust silencer required
- Requires external radiator

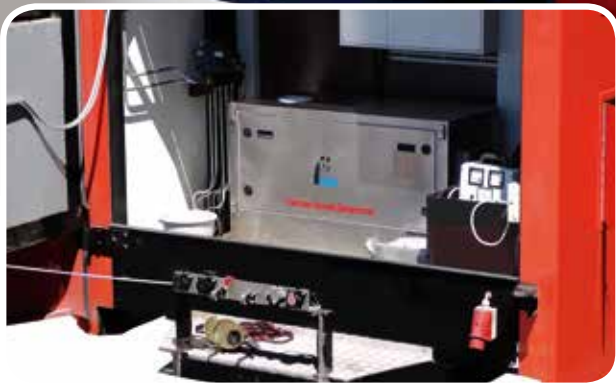

Panda PVK-UK

Vehicle generator "Compact Construction" with integrated cooling system for mounting externally on the vehicle chassis.



- Designed for external mounting
- Assembly bolts pre-fitted to housing
- Metal capsule with a heavy-duty cover
- Wide access hatch for easier access
- Sound insulation capsule
- Water-cooled exhaust silencer inside capsule
- No additional exhaust silencer required
- Integrated radiator and cooling system

Panda PSC

Self-Contained generators are complete "turnkey" units fitted with an integrated cooling system, fuel-tank and electrical cabinet.



- Integrated fuel tank
- Vertically or horizontally mounted radiator
- Suitable for external mounting
- Sound insulation capsule
- Water-cooled exhaust silencer inside capsule
- No additional exhaust silencer required
- Integrated radiator and cooling system

Technical data for Fischer Panda vehicle generators

"Perfect Power" iSeries generators

Fischer Panda iSeries generators take full advantage of modern diesel engines designed to run at lower speeds and meet current emission standards. Engine speed is adjusted automatically according to the electrical load which makes it economical to run. These generators are ideal for powering varying load profiles.

Perfect Power

"Compact Power" Panda / xSeries generators

These generators are fitted with Voltage Control System (VCS) or xControl which progressively controls the engine speed. This has an enormously positive effect on the exhaust emissions. The generator achieves up to 15 % more effective performance than other non-controlled generators. The voltage is adjusted with a tolerance of ± 3 V in the range up to 80 % of the nominal performance. Capacitors (used for boosting the starting current) are fitted in an external AC control box for the standard versions of Premium Line generators up to Panda 18.

Compact Power

Panda generator Model / type	Generator nominal performance						Voltage tolerance	Engine manufacturer	Engine type	Displacement cm ³	No. of cylinders	Sound level [dBA] (7m / 3m / 1m)
	HP1		HP3		DVS							
	(kW)	(kVA*)	(kW)	(kVA)	(kW)	(kVA)						
	230 V 1 Phase 50 Hz		400 V 3 Phase 50 Hz		230 / 400 V 1 + 3 Phase 50 Hz							
Perfect Power : iSeries Panda marine generators												
Panda 5000i	0-4,0	5	-	-	-	-	± 3 V	Kubota	EA300	309	1	54 / 64 / 68
Panda 8000i	0-6,4	8,0	-	-	-	-	± 3 V	Kubota	Z482	479	2	52 / 62 / 67
Panda 10000i	0-8,0	10,0	0-8,0	10,0	-	-	± 3 V	Kubota	Z602	599	2	52 / 62 / 67
Panda 15000i-230V	0-12,0	15,0	-	-	-	-	± 3 V	Kubota	D902	898	3	54 / 64 / 68
Panda 15000i-400V			0-12,0	15,0				Kubota	D902	898	3	54 / 64 / 68
Panda 25i-230 V	0-20,0	25,0	-	-	-	-	± 3 V	Kubota	V1505	1498	4	54 / 64 / 68
Panda 25i-400 V			0-20,0	25,0				Kubota	V1505	1498	4	54 / 64 / 68
Panda 45i	-	-	0-36,0	45,0	-	-	± 3 V	Kubota	V2403T	2434	4	55 / 65 / 69
Compact Power : Panda / xSeries generators - 3000 rpm - 50 Hz												
Panda 8000x / Panda 8000	6,8	8,0	6,8	8,0	6,0	6,0	± 3 V	Kubota	Z482	479	2	52 / 62 / 67
Panda 10000x / Panda 10000	8,0	9,4	8,0	9,4	7,0	7,0	± 3 V	Kubota	Z602	599	2	52 / 62 / 67
Panda 12000x / Panda 12000	10,2	12,0	10,2	12,0	9,0	9,0	± 3 V	Kubota	D722	719	3	53 / 63 / 67
Panda 15000x / Panda 15000	12,7	15,0	12,7	15,0	11,1	11,1	± 3 V	Kubota	D902	898	3	54 / 64 / 68
Panda 18x / Panda 18	15,3	18,0	15,3	18,0	13,5	13,5	± 3 V	Kubota	D1105	1123	3	55 / 65 / 69
Panda 24x / Panda 24	20,4	24,0	20,4	24,0	18,0	18,0	± 3 V	Kubota	V1505	1498	4	55 / 65 / 69
Panda 30x / Panda 30	25,5	30,0	25,5	30,0	22,4	22,4	± 3 V	Kubota	V1505T	1498	4	55 / 65 / 69
Panda 40	-	-	37,0	43,5	-	-	± 3 V	Lombardini	LDW 2204T	2199	4	55 / 65 / 69

*) For inverter generators: output performance is calculated with a Cos Phi factor 0.8 up to 40 °C ambient temperature, otherwise calculate with factor 1.0 up to 50 °C.

*) For asynchronous generators (up to and including Panda 15000), the KVA is calculated with Cos Phi 0.85 for a short starting performance of inductive consumers. Otherwise it should be calculated with factor 1.0. Generators above and including Panda 16 are calculated with an optional start performance with compensation or starting current booster, otherwise it should be calculated with a factor of 1.



PVMV-N (up to 30 kW)



PVK-U



PVM-NE (above 30 kW)

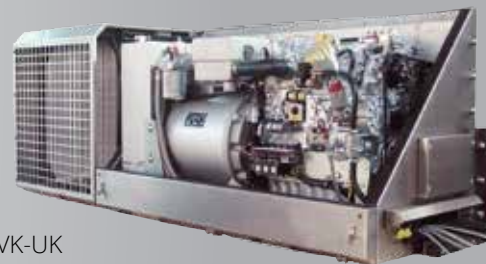

PVK-UK

for internal installation				for installation under the chassis											
PVMV-N (up to 30 kW) / PVM-NE (from 30 kW)				PVK-U				PVK-UK							
Approx. capsule dimensions L x W x H) mm	Weight incl. capsule (kg)	Standard capsule type	Standard sound insulation	Approx. capsule dimensions L x W x H) mm	Weight incl. capsule (kg)	Standard capsule type	Standard sound insulation	Approx. capsule dimensions L x W x H) mm	Weight incl. capsule (kg)	Standard capsule type	Standard sound insulation	Approx. capsule dimensions L x W x H) mm	Weight incl. capsule (kg)	Standard capsule type	Standard sound insulation
780 x 460 x 430	120	GFK	4DS	761 x 447 x 440	140	MPL	4DS	1204 x 445 x 460	176	MPL	4DS				
760 x 515 x 609	192	GFK	4DS	780 x 530 x 620	220	MPL	4DS	1295 x 531 x 621	265	MPL	4DS				
760 x 515 x 609	195	GFK	4DS	809 x 530 x 620	242	MPL	4DS	1426 x 530 x 620	300	MPL	4DS				
910 x 515 x 619	230	GFK	4DS	910 x 530 x 600	275	MPL	4DS	1516 x 530 x 625	355	MPL	4DS				
910 x 515 x 619	230	GFK	4DS	910 x 530 x 600	275	MPL	4DS	1516 x 530 x 625	355	MPL	4DS				
1070 x 650 x 690	335	MPL	4DS	request	request	MPL	4DS	1715 x 534 x 691	460	MPL	4DS				
1070 x 650 x 690	335	MPL	4DS	request	request	MPL	4DS	1715 x 534 x 691	460	MPL	4DS				
1412 x 660 x 880	662	MPL	4DS	1449 x 696 x 820	675	MPL	4DS	not available in this version							
870 x 515 x 634	230	GFK	4DS	870 x 523 x 580	279	MPL	4DS	1330 x 522 x 620	332	MPL	4DS				
910 x 515 x 630	240	GFK	4DS	910 x 522 x 620	290	MPL	4DS	1516 x 522 x 620	340	MPL	4DS				
950 x 515 x 629	253	GFK	4DS	960 x 530 x 625	317	MPL	4DS	1566 x 530 x 625	370	MPL	4DS				
1010 x 515 x 634	316	GFK	4DS	1000 x 530 x 630	365	MPL	4DS	1606 x 522 x 630	430	MPL	4DS				
1100 x 540 x 680	415	MPL	4DS	1100 x 560 x 680	440	MPL	4DS	1736 x 560 x 680	544	MPL	4DS				
1220 x 540 x 680	465	MPL	4DS	1225 x 542 x 684	492	MPL	4DS	1854 x 542 x 684	492	MPL	4DS				
1270 x 570 x 700	512	MPL	4DS	1270 x 570 x 690	530	MPL	4DS	1970 x 564 x 640	687	MPL	4DS				
1398 x 650 x 780	690	MPL	4DS	request	request	MPL	4DS	2000 x 950 x 800	request	MPL	4DS				

Dimensions apply for the sound insulation capsule only and do not include latches, fittings etc. Additional room will need to be calculated for the installation to include hoses, cables and capsule mountings. Please confirm current dimensions and weights when ordering.

Technical data for Fischer Panda vehicle generators

“Compact Power” HD generators

These “Heavy Duty” generators are fitted with Voltage Control System (VCS) which progressively controls the engine speed. This has an enormously positive effect on the exhaust emissions. The generator achieves up to 15 % more effective performance than other non-controlled generators. The voltage is adjusted with a tolerance of ± 3 V in the range up to 80 % of the nominal performance. Capacitors (used for boosting the starting current) are fitted in an external AC control box for the standard versions of Premium Line generators up to Panda 18.

Compact Power

“Hybrid Power” DC generators

Fischer Panda battery charging generators produce direct current and generally function as part of a Hybrid Power System. Battery levels are monitored and automatically charged by the generator. An inverter supplies energy to the 230 V consumers on-board. These systems are ideal for typically varying power demands which do not require a generator to constantly run throughout the day.

Hybrid Power

Panda generator Model / type	Generator nominal performance						Voltage tolerance	Engine manufacturer	Engine type	Displacement cm ³	No. of cylinders	Sound level [dBA] (7m / 3m / 1m)
	HP1		HP3		DVS							
	230 V 1 Phase 50 Hz (kW) (kVA*)	400 V 3 Phase 50 Hz (kW) (kVA)	230 / 400 V 1 + 3 Phase 50 Hz (kW) (kVA)									

Fischer Panda „Compact Power“ : 1500 rpm - 50 Hz “Heavy Duty” generators with VCS voltage control

Panda 7,5-4	6,5	7,6	6,5	7,6	-	-	± 3 V	Kubota	D1105	1123	3	52 / 62 / 66
Panda 9-4	8,0	9,4	8,0	9,4	-	-	± 3 V	Kubota	D1105	1123	3	52 / 62 / 66
Panda 12-4	10,5	12,3	10,5	12,3	-	-	± 3 V	Kubota	V1505	1647	3	52 / 62 / 66
Panda 22-4	18,6	21,9	18,6	21,9	-	-	± 3 V	Kubota	V2403	2434	4	53 / 63 / 67
Panda 30-4	25,0	29,4	25,0	29,4	-	-	± 3 V	Mitsubishi	MI S4S	3331	4	request
Panda 40-4	-	-	35,0	41,1	-	-	± 3 V	Mitsubishi	MI S4SDT	3331	4	request
Panda 50-4	-	-	40,0	47,0	-	-	± 3 V	JCB	NA-47	4399	4	request
Panda 60-4	-	-	50,0	59,0	-	-	± 3 V	Deutz	DZ BF4M2012C	4040	4	request
Panda 70-4	-	-	61,0	72,0	-	-	± 3 V	Deutz	DZ BF4M2012C	4764	4	request
Panda 85-4	-	-	73,0	86,0	-	-	± 3 V	Deutz	DZ BF4M1013EC	4764	4	request
Panda 110-4	-	-	92,0	109,0	-	-	± 3 V	Deutz	DZ BF6M1013EC	7146	6	request
Panda 130-4	-	-	111,0	130,0	-	-	± 3 V	Deutz	DZ BF6M1013EC	7146	6	request

Fischer Panda „Hybrid Power“: Panda AGT-DC battery charging generators

Model / Type AGT generator	Nominal performance (kW)	Continuous performance (kW)	Nominal voltage (DC)	Constant current rate (A)	Engine speed	Voltage tolerance	Engine manufacturer	Engine type	Displacement cm ³	No. of cylinders	Sound level [dBA] (7m / 3m / 1m)
AGT-DC 4000-12	4	3,2	12	220	2400-3000	± 3 V	Kubota	EA300	309	1	55 / 65 / 69
AGT-DC 4000-24	4	3,2	24	110	2400-3000	± 3 V	Kubota	EA300	309	1	52 / 62 / 67
AGT-DC 5000-12	4,5	3,6	12	250	1800-2200	± 3 V	Kubota	Z482	479	2	52 / 62 / 67
AGT-DC 6000-24	5,5	4,8	24	170	2400-3200	± 3 V	Kubota	Z482	479	2	52 / 62 / 67
AGT-DC 8000-24	8	6,4	24	220	2200-2600	± 3 V	Kubota	D722	719	3	53 / 63 / 67
AGT-DC 12000	12	request		request	± 3 V	Kubota	D902	898	3	54 / 64 / 68	
AGT-DC 14000	14	request		request	± 3 V	Kubota	D1105	1123	3	55 / 65 / 69	
AGT-DC 16000	16	request		request	± 3 V	Kubota	V1505	1498	4	55 / 65 / 69	
AGT-DC 25000	25	request		request	± 3 V	Kubota	V1505T	1498	4	55 / 65 / 69	
AGT-DC 28000	28	request		request	± 3 V	Kubota	V2403	2434	4	55 / 65 / 69	

For asynchronous generators (up to and including Panda 15000), the KVA is calculated with Cos Phi 0.85 for a short starting performance of inductive consumers. Otherwise it should be calculated with factor 1.0. Generators above and including Panda 16 are calculated with an optional start performance with compensation or starting current booster, otherwise it should be calculated with a factor of 1.



PVMV-N (up to 30 kW)

PVK-U



PVM-NE (above 30 kW)



PVK-UK

for internal installation				for installation under the chassis							
PVMV-N (up to 30 kW) / PVM-NE (from 30 kW)				PVK-U				PVK-UK			
Approx. capsule dimensions L x W x H mm	Weight incl. capsule (kg)	Standard capsule type	Standard sound insulation	Approx. capsule dimensions L x W x H mm	Weight incl. capsule (kg)	Standard capsule type	Standard sound insulation	Approx. capsule dimensions L x W x H mm	Weight incl. capsule (kg)	Standard capsule type	Standard sound insulation
1055 x 515 x 665	338	GFK	4DS	request	request	MPL	4DS	request	request	MPL	4DS
1140 x 730 x 700	389	MPL	4DS	1100 x 560 x 680	544	MPL	4DS	request	request	MPL	4DS
1170 x 540 x 700	435	MPL	4DS	request	request	MPL	4DS	request	request	MPL	4DS
1390 x 730 x 770	643	MPL	4DS	1390 x 600 x 760	643	MPL	4DS	request	request	MPL	4DS
1473 x 690 x 890	800	MPL	4DS	request	request	MPL	4DS	request	request	MPL	4DS
1560 x 710 x 950	867	MPL	4DS								
1581 x 730 x 980	891	MPL	4DS								
1885 x 790 x 1000	1298	MPL	6DS								
request	request	MPL	6DS								
request	request	MPL	6DS								
request	request	MPL	6DS								
request	request	MPL	6DS								

Approx. capsule dimensions (excl. fittings) L x W x H (mm)	Weight incl. capsule (kg)	Standard capsule type	Standard sound insulation	Approx. capsule dimensions (excl. fittings) L x W x H (mm)	Weight incl. capsule (kg)	Standard capsule type	Standard sound insulation	Approx. capsule dimensions (excl. fittings) L x W x H (mm)	Weight incl. capsule (kg)	Standard capsule type	Standard sound insulation
770 x 450 x 430	120	GFK	4DS	request	request	MPL	4DS	1210 x 450 x 440	148	MPL	4DS
770 x 450 x 430	120	GFK	4DS	request	request	MPL	4DS	1210 x 450 x 440	148	MPL	4DS
750 x 505 x 615	189	GFK	4DS	request	request	MPL	4DS	request	request	MPL	4DS
760 x 515 x 609	189	GFK	4DS	request	request	MPL	4DS	request	request	MPL	4DS
860 x 515 x 614	216	GFK	4DS	request	request	MPL	4DS	request	request	MPL	4DS
request	request	GFK	4DS	request	request	MPL	4DS	request	request	MPL	4DS
request	request	GFK	4DS	request	request	MPL	4DS	request	request	MPL	4DS
1100 x 550 x 690	366	MPL	4DS	request	request	MPL	4DS	request	request	MPL	4DS
request	request	MPL	4DS	request	request	MPL	4DS	request	request	MPL	4DS
request	request	MPL	4DS	request	request	MPL	4DS	request	request	MPL	4DS

Dimensions apply for the sound insulation capsule only and do not include latches, fittings etc. Additional room will need to be calculated for the installation to include hoses, cables and capsule mountings. Please confirm current dimensions and weights when ordering.

Roof-mounted radiators from Fischer Panda

RD 1.2



RD2.2



Fan controller



Expansion tank

Radiator	Voltage	Weight (dry)	Approximate dimensions (L x W x H) mm	Article no.	Suited for generator model												
					Panda 5000i	Panda 8000i	Panda 10000i	Panda 15000i	Panda 25i	Panda 45i	Panda 8000	Panda 10000	Panda 12000	Pande 15000	Panda 18	Panda 24	Panda 30
RD-D: Roof radiators DC																	
RD 1.2	24 V	18	705 x 390 x 310	0000472	x												
RD 2.2	24 V	29	930 x 515 x 321	0022841		x	x			x	x						
RD 3.2	24 V	32	1055 x 515 x 312	0000426			x	x				x	x				
RD 3.2 Trop	24 V	40	1055 x 515 x 361	0000425			x	x				x	x				
RD-A: Roof radiators AC																	
RD 3.3	230 V / 50 Hz	36	1055 x 515 x 369	0005837	x	x	x	x			x	x	x	x			
RD 3.3 Trop	230 V / 50 Hz	42	1055 x 515 x 364	0022812		x	x	x			x	x	x	x			
RD 4.2	230 V / 50 Hz	32	735 x 705 x 395	0022807		x	x	x			x	x	x	x			
RD 16.2	230 V / 50 Hz	56	1040 x 630 x 392	0022808											x	x	
RD 6 / 2.2	230 V / 50 Hz	67	1405 x 630 x 414	0022813													x
RD 6 / 2.2 Dual	230 V / 50 Hz	104	1405 x 640 x 493	0005742					x								
RD 7.2	400 V / 50 Hz		858 x 940 x 502	0000418													x
RD 7.2 Dual	400 V / 50 Hz		1011 x 920 x 597	0005730						x							
RD 8.2	400 V / 50 Hz		1087 x 1177 x 512	0000417													
RD P75 MB	400 V / 50 Hz		request	0022809													
RD P100 MB	400 V / 50 Hz		request														
RD P110 MB	400 V / 50 Hz		request	0000419													

¹⁾ No value = on request. Fischer Panda GmbH reserves the right to change technical information without prior notice.



Radiator Model	Voltage	Suited for generator model																					
		Panda 7,5-4	Panda 09-4	Panda 12-4	Panda 17-4	Panda 22-4	Panda 30-4	Panda 40-4	Panda 50-4	Panda 60-4	Panda 70-4	Panda 85-4	Panda 110-4	Panda 130-4	AGT 4.000-12	AGT 4.000-24	AGT 5.000-12	AGT 6.000-24	AGT 8.000-24	AGT 12.000-48	AGT 14.000-48	AGT 16.000-48	AGT 25.000-48
RD-D: Roof radiators DC																							
RD 1.2	24 V															x	x						
RD 2.2	24 V	x	x															x	x				
RD 3.2	24 V			x																x	x		
RD 3.2 Trop	24 V																			x	x		
RD-A: Roof radiators AC																							
RD 3.3	230 V / 50 Hz	x	x	x																			
RD 3.3 Trop	230 V / 50 Hz	x	x	x																			
RD 4.2	230 V / 50 Hz	x	x	x														x	x	x	x		
RD 16.2	230 V / 50 Hz				x	x																x	x
RD 6/2.2	230 V / 50 Hz							x	x														
RD 6/2.2 Dual	230 V / 50 Hz																						
RD 7.2	400 V / 50 Hz								x														
RD 7.2 Dual	400 V / 50 Hz									x													
RD 8.2	400 V / 50 Hz										x												
RD P75 MB	400 V / 50 Hz											x											
RD P100 MB	400 V / 50 Hz												x										
RD P110 MB	400 V / 50 Hz													x									

Side and under-vehicle radiators from Fischer Panda



RV3.2

RV13.160

Fan controller

Expansion tank

Radiator	Voltage	Weight (dry)	Approximate dimensions (L x W x H) mm	Article no.	Suited for generator model												
					Panda 5000i	Panda 8000i	Panda 10000i	Panda 15000i	Panda 25i	Panda 45i	Panda 8000	Panda 10000	Panda 12000	Panda 15000	Panda 18	Panda 24	Panda 30
RV-D: Side-/underneath radiators DC																	
RV 1.2	24 V	13	620 x 330 x 214	0000448	x												
RV 2.2	24 V	21	750 x 450 x 224	0000451		x	x				x	x					
RV 3.2	24 V	24	880 x 450 x 224	0000449			x	x					x	x			
RV 3.2 Trop	24 V	30	920 x 450 x 254	0000452			x	x					x	x			
RV-A: Side-/underneath radiators AC																	
RV 3.3	230 V / 50 Hz	30	880 x 450 x 210	0005839	x	x	x	x			x	x	x	x			
RV 3.3 Trop	230 V / 50 Hz	33	920 x 450 x 259	0005817		x	x	x			x	x	x	x			
RV 5.2	230 V / 50 Hz	32	580 x 610 x 356	0005793		x	x	x			x	x	x	x			
RV 13.160	230 V / 50 Hz	52	601 x 690 x 441	0005799											x	x	
RV 6/2.2	230 V / 50 Hz		1280 x 550 x 322	0005808													x
RV 6/2.2 Dual	230 V / 50 Hz	81	1280 x 556 x 378	0005801					x								
RV 14.120	400 V / 50 Hz	48	690 x 780 x 355	0022804												x	x
RV 14.160	400 V / 50 Hz	55	690 x 780 x 407	0005814													x
RV 7.2	400 V / 50 Hz	63	800 x 1000 x 416	0000428													
RV 7.2 Dual	400 V / 50 Hz	78	940 x 800 x 438	0005798						x							
RV 8.2	400 V / 50 Hz		1012 x 1100 x 396	0005786													
RV P75 MB Dual	400 V / 50 Hz		1900 x 1070 x 421	0005813													
RV P75 MB	400 V / 50 Hz		1270 x 1100 x 455	0005792													
RV P85/4	400 V / 50 Hz			0005795													

¹⁾ No value = on request. Fischer Panda GmbH reserves the right to change technical information without prior notice.



Radiator Model	Voltage	Suited for generator model																					
		Panda 7,5-4	Panda 09-4	Panda 12-4	Panda 17-4	Panda 22-4	Panda 30-4	Panda 40-4	Panda 50-4	Panda 60-4	Panda 70-4	Panda 85-4	Panda 110-4	Panda 130-4	AGT 4.000-12	AGT 4.000-24	AGT 5.000-12	AGT 6.000-24	AGT 8.000-24	AGT 12.000-48	AGT 14.000-48	AGT 16.000-48	AGT 25.000-48
RV-D: Side-/underneath radiators DC																							
RV 1.2	24 V														x	x							
RV 2.2	24 V	x	x														x	x					
RV 3.2	24 V			x															x	x			
RV 3.2 Trop	24 V																		x	x			
RV-A: Side-/underneath radiators AC																							
RV 3.3	230 V / 50 Hz	x	x	x																			
RV 3.3 Trop	230 V / 50 Hz	x	x	x																			
RV 5.2	230 V / 50 Hz	x	x	x													x	x	x	x			
RV 13.160	230 V / 50 Hz				x	x															x	x	
RV 6/2.2	230 V / 50 Hz																					x	x
RV 6/2.2	230 V / 50 Hz																						
RV 14.120	400 V / 50 Hz							x	x														x
RV 14.160	400 V / 50 Hz							x															
RV 7.2	2x400 V / 50 Hz								x														
RV 7.2	1x400 V / 50 Hz																						
RV 8.2	400 V / 50 Hz									x													
RV P75 MB Dual	400 V / 50 Hz																						
RV P75 MB	400 V / 50 Hz										x	x											
RV P85/4	400 V / 50 Hz											x											



Fischer Panda power for rail and locomotive applications

Generators for railway applications

- Auxiliary power and charging
- Maintenance wagon equipment
- Accommodation carriage systems

Fischer Panda generators are installed on a variety of railway applications providing battery charging for the locomotives, powering equipment used by maintenance wagons or supplying power to accommodation carriages.

Generators provide power to each of four accommodation carriages on board the luxury Danube Express, supplying electrical systems for air-conditioning, en suite showers and cabin lighting. The quiet supply of power is also of importance during overnight stops in cities. The operation of locomotive engines at night are often restricted due to noise levels.

The generators are also used as auxiliary power sources supplying power for tasks which are usually powered by idling the locomotive's engine such as cabin heating or preventing cooling systems from freezing in winter weather. AC generators are also used on maintenance wagons to power tools, compressors, pumps and floodlighting during track repair and replacement.

The generator's low profile is ideal for mounting externally underneath the wagon. The heavy-duty sound shield provides additional protection if the generator is installed externally.



Radiator mounted separately on wagon roof

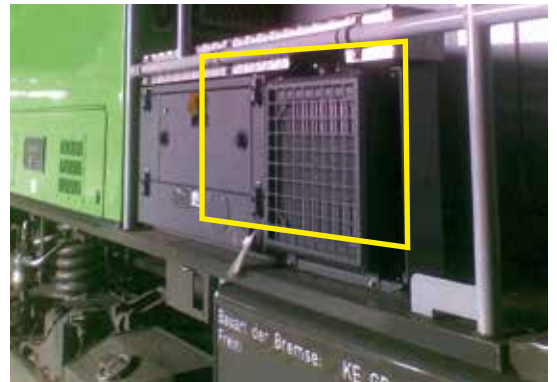

External Fischer Panda DC generator with side-mounted radiator.

Even when the unit is completely submerged under drifting snow, the raised exhaust and air intakes allow the generator to continue operating.



Fischer Panda power for isolated and unmanned applications

Ideal for remote communication and monitoring

- Extremely long service interval (up to 1500 hours)
- Fully automatic operation and monitoring
- Hybrid Systems: combine with battery, solar and wind power

Fischer Panda generators are ideal for remote communication and monitoring sites. Their compact and robust design makes them suitable for operating in remote areas and exposed locations. These sites are often unmanned and operate for prolonged periods, requiring only routine maintenance schedules and refueling.

Fischer Panda Hybrid-DC generators provide powerful battery charging capabilities and can be integrated with wind and solar-based systems. The generator starts and stops automatically when the battery banks require recharging.

Fischer Panda AC generators are especially suited for applications which require even more continuous power such as providing extra coverage at large events. The iSeries generators with iControl are designed to allow longer periods between maintenance schedules when operating with lower loads.

Options and services are available to meet individual specifications and requirements. The generators are designed to be connected to an external fuel source within a container-based system. Generators with integrated fuel tank and electrical distribution are available on request.



This 12 kW Panda, inside a mobile GSM station from Czech company Meico Systems, carried out 24-hour operational periods for over one and a half years. The unit operated for more than 19,960 hours; stopping only for routine servicing and minor repairs.





Fischer Panda power for off-grid buildings

Energy for mountain hostels and weekend homes

- Power for off-grid and remote buildings
- Co-generation (electric power and heating)
- Hybrid systems: combine with battery, solar and wind power

Fischer Panda generators are ideal for supplying power to off-grid or remotely located buildings such as mountain hostels, weekend homes or even alpine huts. The generator's low space requirements and compact construction is suited for buildings where space is limited. Effective sound shielding reduces operating noise and low vibrations. The generator is easy to operate using a panel which also features an automatic start.

Power is available for larger consumers including electric cooking, boilers and even air-conditioning. Guests can also enjoy the comfort of being able to use domestic consumer appliances such as hair dryers and coffee makers.

The generator can also be used to form an effective Combined Heat and Power system (CHP) system. This uses heat from the exhaust and radiator to supply the water-heating system while the generator is running. The system's overall efficiency is increased. Fuel supply may be an important factor in remote locations. Options for using alternative fuels are available on request. A higher degree of efficiency can be achieved if used in a hybrid system with battery, solar and wind power.



This three-phase Panda is installed in the basement. Main fuses, panel and radiator control are fitted in electrical cabinet.
Image: Kratos Kft. Hungary.

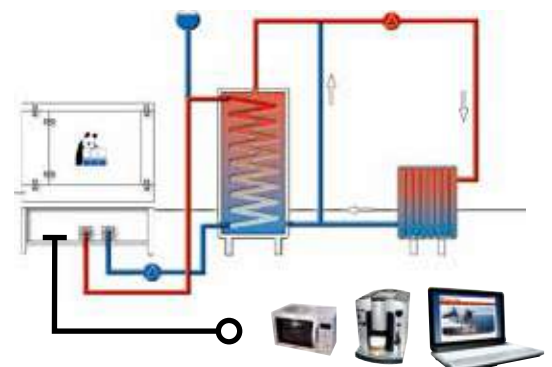

Overall efficiency can be increased when excess heat from engine (exhaust and cooling) is also used to heat water when electrical energy is generated.



Fischer Panda power for utility-connected homes

Cogeneration with iSeries generators

- Increase supply safety with “Islanding” option
- Grid-feeding capabilities
- Alternative fuels available on request

The new iSeries are the latest range of compact, quiet and powerful Fischer Panda generators designed for co-generation applications. These offer both feed-in (supplying unused energy in the grid) and islanding (for backup operations or applications without grid connection).

Utilizing the independent (variable) operating speed of the engine, grid supply is achieved by using inverter technology. Electrical grids are supplied by solar photovoltaic (PV) installations in the same way.

Typically, most co-generation units without inverter technology use fixed-speed engines - these are set to operate either at 3000 rpm (2-pole) or 1500 rpm (4-pole). The speed of the iSeries generator can vary and its output is optimally matched to the engine speed.

An “Islanding Inverter” is optionally available. This secures the supply for continuous operation if the grid fails. The setup provides greater safety and independence from grid failure coupled with the latest grid feed technology.

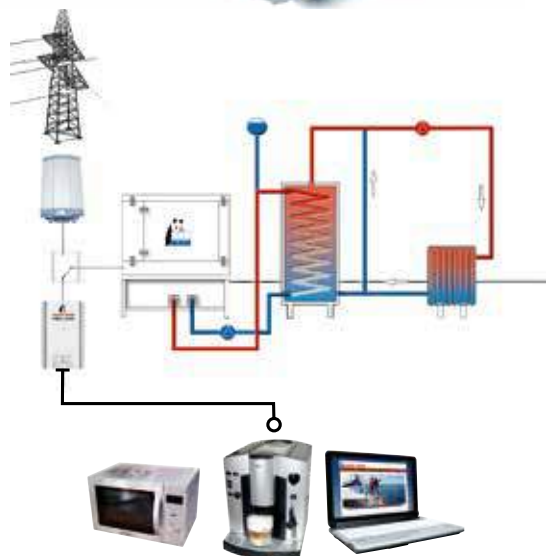



Installation services and support from Fischer Panda

Installation kits

Fischer Panda supplies installation kits with all the necessary cables, hoses, connection pieces and accessories to ensure the system can be correctly installed inside the vehicle or externally on the chassis. Specific hose and cable lengths are available on request.



Custom services for special requirements

Fischer Panda offers extensive services for adapting generators for use with special equipment and commercial applications. This includes electro-magnetic hydraulic couplings for driving mechanical-hydraulic pumps and also mounting slides to provide access to the generator while servicing.



Powerful energy systems

Fischer Panda Generators form the backbone of our intelligent and innovative solutions whether you are upgrading an existing installation, connecting to another system or ensuring you have sufficient energy when a land power connection is not available.





Fischer Panda SOS-24/7 hotline

For urgent enquiries or generator failure outside our normal business hours, you can ring the Fischer Panda international switchboard on +49 5254 9202-767 (SOS on a key-operated telephone). Please leave your name, number and the purpose of your call on the answerphone / voice mail. This service is operated 24/7 by employees at Fischer Panda.



Global Service Directory

With a coordinated network of distributors, dealers and service stations, Fischer Panda has trained specialists and a worldwide dealer network ready to help, give advice and recommend the best service station depending on the location of your vehicle or yacht.. The Global Service Directory can be downloaded from the company website at: <http://www.fischerpanda.de/globalservice>



Service kits

Fischer Panda Service Kits contain original parts which meet the required specifications and are suited for normal workshop servicing. Fischer Panda Service "Plus" Kits contain all the relevant spare parts for the first 600 hour service interval. Service Plus kits are supplied in a handy waterproof plastic box so all the items are protected during storage.

The Fischer Panda Installation Guide can be downloaded from the company website at: <http://www.fischerpanda.de/installation>





Fischer Panda GmbH
Otto-Hahn-Str. 40
D-33104 Paderborn
Germany

Tel. : +49 (0)5254 9202-0
Fax : +49 (0)5254 9202-550
Email : info@fischerpanda.de
Web : www.fischerpanda.de

Disclaimer:

The information contained here is to the best of our knowledge accurate at the date of publication. Please note that the data in this publication reflects the technical state at time of print. Dimensions apply for the sound insulation capsule only and do not include latches, fittings, etc. Additional room will need to be calculated for installation to include hoses, cables and capsule mountings. Additional components or alternators may also affect capsule dimensions. Due to our policy of continual product development, we reserve the right to alter technical specifications without notice. All performance data relates to air and water temperatures of 20°C. Performance reduction (approx. 1% per 100m height and approx 2% per 5°C air temperature and approx. 1% per 1°C water temperature above 20°C)

Stand: 01-2016 Art. 71.02.01.06H