

EVAKOOL®

PLATINUM UPRIGHT

INSTRUCTION MANUAL

FOR MODELS
DC95 / DC110



CHILLED FOR GOOD TIMES

Please read operating manual carefully before using your unit.

Please keep manual in a safe place.

If lost you can find a digital copy at Evakool.com.au or contact Evakool on 1300 865 665.

Contents

1	Safety Instructions	4
2	Notes on Using The Product.....	4
3	Operation Instructions	4
4	Cleaning & Maintenance	6
5	Troubleshooting	6
6	Installation Guide.....	8
7	Cross Flow Ventilation.....	9
8	Warranty Statement	12

Key Product Features

- Powered by 12 Volt DC Compressor.
- Reliable electronics, high efficiency, low energy consumption.
- Lockable door for travel.
- Separate freezer compartment.
- Operates in temperatures from 10°C to 43°C. Covers all climates SN, N, ST, T.
- Vegetable crisper.
- Low ambient heater.



1 Safety Instructions

- Warning: Do not use your unit if any cabling is damaged, frayed or exposed.
- Warning: Do not attempt or continue to operate your unit if it is wet.
- When using the unit ensure the circuit being used has a fuse or circuit breaker, recommended size for DC 12 Volt is 15 Amp, DC 24 Volt is 7.5 Amp.
- Make sure the voltage is within the correct range for socket and cable being used.
- Do not place any electrical devices inside the refrigerator as they may be damaged.

2. Notes On Using The Product

- Your unit requires good ventilation; allow a gap of at least 50mm around the refrigerator.
- Do not allow a large amount of frost to build up on the inside walls as this may impair cooling. Defrost by turning the unit off, allowing the frost to melt and wiping out the water.
- The lower the ambient temperature, the lower the power usage. In order to maximise efficiency keep the unit in a cool location out of direct sunlight.
- It is recommended to operate the unit on a flat surface, but it will operate at angles up to 30°.

3. Operation

- **Power:** DC (12 and 24 Volt)
- Cable Length Specification

The DC cables must have a suitable cross-section for their length (measured from the battery to the unit), according to this table:

Cable Thickness (Area)		12V Max Cable Length		24V Max Cable Length	
(mm ²)	AWG	(m)	(ft)	(m)	(ft)
2.5	14	2.5	8	5	16
4	12	4	13	8	26
6	10	6	20	12	39
10	8	10	33	20	66

The refrigerator is fitted with an Anderson style plug connection. Ensure cabling to the fridge is also fitted with this style plug, this will guarantee the best connection and minimise voltage drop.

Control Panel

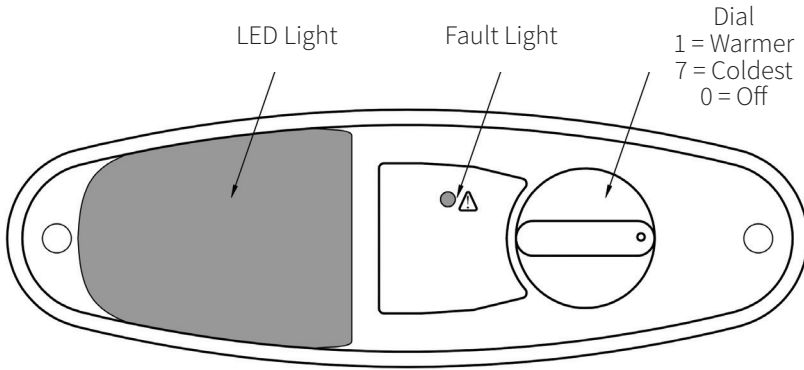

- Connect fridge to 12 or 24V DC.

Power Source	Cut Off Voltage	Cut In Voltage
12V DC	10.4V	11.7V
24V DC	22.8V	24.2V

- Ensure correct voltage is applied to run the fridge (see graph).
- Set thermostat to the desired setting. We recommend starting at 3. Allow 24 hours for the cabinet to come down to temperature and settle in.
- To make the fridge colder, turn dial to a high number and to make the fridge warmer turn to a lower number.
- 0 is the 'OFF' position.
- **Note:** Always allow 24 hours after any adjustment for temperatures to settle.

Low Ambient Heater

What it does: In low ambient temperatures 12°C and under, there is not enough heat in the air to cycle the fridge back on, so a heater is needed to assist this to happen.

What do I need to do? Absolutely nothing. The heater is controlled electronically, so during the colder months the fridge senses when it is needed and activates this function.

4. Cleaning & Maintenance

- Clean the appliance inside and out with a clean damp cloth every week. If it is dirty, use sodium bicarbonate dissolved in lukewarm water to clean the unit.
- Never use abrasive products, detergents or soap. After cleaning, wipe out with a clean damp cloth and dry carefully.
- Do not store product inside unit if the unit is not on
- Do not store the unit if it is wet inside or without leaving the door open.
- Never clean the unit under running water. Do not use abrasive cleaning agents or hard objects during cleaning as these can damage the unit.

5. Troubleshooting

The Unit is Not Turning On

- Check whether the unit has been turned on.
- Check the power supply (try a different power source/vehicle/socket).
- Check whether the plug and the socket have a good connection.
- Check whether the circuit breaker has tripped (located on the back of the fridge in the compressor bay).

Low Refrigeration Performance

- Too much product been placed inside the unit.
- There is too much warm product inside the unit .
- The door is unlatched / or open.
- The seal is broken.
- Problems arising from poor ventilation (allow 50mm of space around the fridge, see diagram).
- The ambient temperature is too high.
- The temperature setting is too high.

Yellow Fault Light Flashing (Located on the Control Panel)

1 Flash every 4 seconds: Low Voltage

- Try on different power source (vehicle or 240V AC power). If changing power source fixed issue, then possible issue with original power source.
- Ensure cabling between fridge and battery is at least 4mm, if the distance is more than 2 metres then use at least 6mm cable.

2 Flashes every 4 seconds: Fan Issue

- Fan is drawing too many amps (over 0.5 amps), replace fan.

3 Flash every 4 seconds: Compressor Start Issue

- Unplug cable and allow unit to rest for 10 minutes.
- Try on different power source (vehicle or 240V AC power).
- Electronic box fault.
- Compressor fault.

4 Flash every 4 seconds: Low Motor Speed

- Reduce products / items inside unit.
- Move so unit is in a lower ambient temperature clean vents / ensure clear air flow over compressor.
- Fan fault.

5 Flash every 4 seconds: Over Temperature

- Ambient temperature too high.
- Clean vents / ensure clear air flow over compressor.
- Fan fault.

Can hear the sound of running water from inside the unit

- This is normal, due to the flow of refrigerant in the unit.

Unusual noise when refrigerator is working

- The refrigerator is not placed on a level surface.

If none of the above solves your issue please contact Evakool on 1300 385 665 or warranty@evakool.com for details of your closest Evakool service centre.

6. Installation Guide

You've bought your refrigerator and you're ready to install it in your car, caravan or camper trailer. Please take the time to ready the following information to ensure your refrigerator will run at its peak efficiency and guarantee you'll get a long life out of your fridge.

- Unpack your new refrigerator and make sure all the parts are there, and that there is no damage to the cabinet.
- Make sure the surface you're attached your mounting bracket to is level and solid.
- Correct air flow and ventilation, this is probably the most important part of the installation. Please read our the Cross Flow Ventilation guide (page 9) for a more in-depth detail on the subject.

Important: The compressor and condensing coil in your fridge, similar to the radiator and motor in your car. The radiator needs cool air passing across it to remove the heat, to stop your engine overheating and eventually failing. The same goes for a refrigerator, if cool air isn't supplied to the condensing coil, the refrigerator will stop performing and serious damage can be done to the compressor.

- Make sure the unit is easy accessible and easy to remove, in case of a warranty repair, the unit needs to be uninstalled and delivered to EvaKool or a recommended service agent as part of the warranty requirements.
- Electrical wiring and installation, should comply to the proper national regulations. See table on page 4 on correct sizing of cable and we also recommend that the wiring be installed by a licensed installer.
- Installing the drain hose (silicone hose located on the back of your fridge). Your refrigerator will produce moisture inside the cabinet and this will need to be drained away.
 - Drill a hole through the floor behind the fridge.
 - Install the silicone hose through the hole.
 - Seal hole with silicone to prevent dust, water and pesky critters entering your car, trailer or van.
- Connect the power to your fridge, and away you go. Job done.

7. Cross Flow Ventilation

Cross flow ventilation ensures that there is sufficient fresh air entering the space where your refrigerator is operating and that the stale hot air is extracted from the area. Fresh air is supplied to the space, through openings or vents, preferable from the outside to reduce the risk of hot air recycling through the condenser. The used hot air is extracted from the space either through natural convection or the use of an extraction fan. This results in cross flow ventilation.

Natural Convection

Warm air naturally will rise up. If you have vents of equal size at the top and bottom of your space, the warm air will naturally rise up and out the top vent which draws cooler air from outside through the bottom vent, this method naturally replaces the hot stale air with fresh cool air automatically. Cross flow, in one vent and out the other.

Extraction Fan

If your space is an odd size, shape or extraction has to go through cupboards or voids, then extraction fans are needed to create the flow of air from your cool air intake vent to your exhaust vent.

Fan Selection

Fan selection is a very important part of this process, the volume of the area where the fridge is kept, needs to be worked out. And the fan selected needs to be able to remove this volume, this is measured in litres per minute (Ltr/Min) or cubic feet per minute (CFM). The other is static pressure of a fan, and this is its ability to push or pull air through resistance. Eg. Through a vent, the fins on the condenser and around corners and obstructions.

As a rule of thumb if specification sheets are not available:

- 120mm Dc fan (minimum)
- 7 blade and aggressive curved blades (air flow and static pressure).
- If noise is going to be an issue, 40dB-A and under is recommended.

Vent Sizing

The bigger the better. For upright fridges 95 litres up to 210 litres we recommend supply vent and exhaust vent be 480mm x 250mm, this allows adequate ventilation and replenishment of hot stale air with fresh cooler air.

Do Not:

- Have only one vent to remove hot air, as this does not work. You need air in and air out, cross flow ventilation is the only way air will move.
- This also applies to fans. A sealed compartment with one opening with a fan in it does not remove the air, again you need cross flow, air in and air out.
- Different size vents, as this limits you to the smallest vent.
- Different size fans for drawing air in and exhausting air out, will limit you to the smallest fan.
- The above rule applies when fitting a fan, if your fan is 120mm then as a minimum your supply opening needs to be the same if not bigger.
- If you are having a supply and extraction fans they have to be the same in their specifications, or you can end up with the air cavitating and not moving at all.

With the introduction of ‘Dust Free’ caravan and campers, this has created a whole new set of issues faced with supplying cool air to your refrigerator, dust reduction filters and extraction fans, also correct use of lockable hatches and vents are necessary to remove the hot air and replace with fresh cool air. This will ensure your fridge will be running at its peak efficiency and guarantee you’ll get a long life from your fridge.

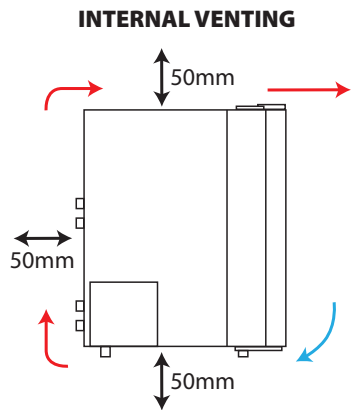
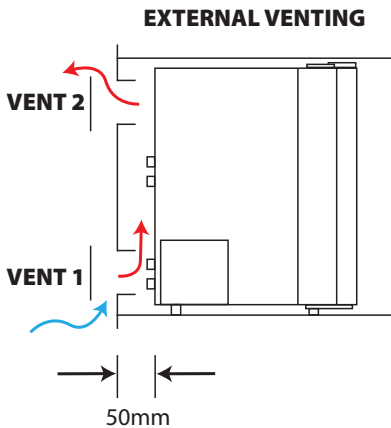

- We recommend 2 vents - 480x250mm.
- One located level with the refrigerator motor.
- Second at the highest point of the fridge cavity, to ensure all hot air escapes.

- 50mm under
- 50mm up the back
- 50mm over the top

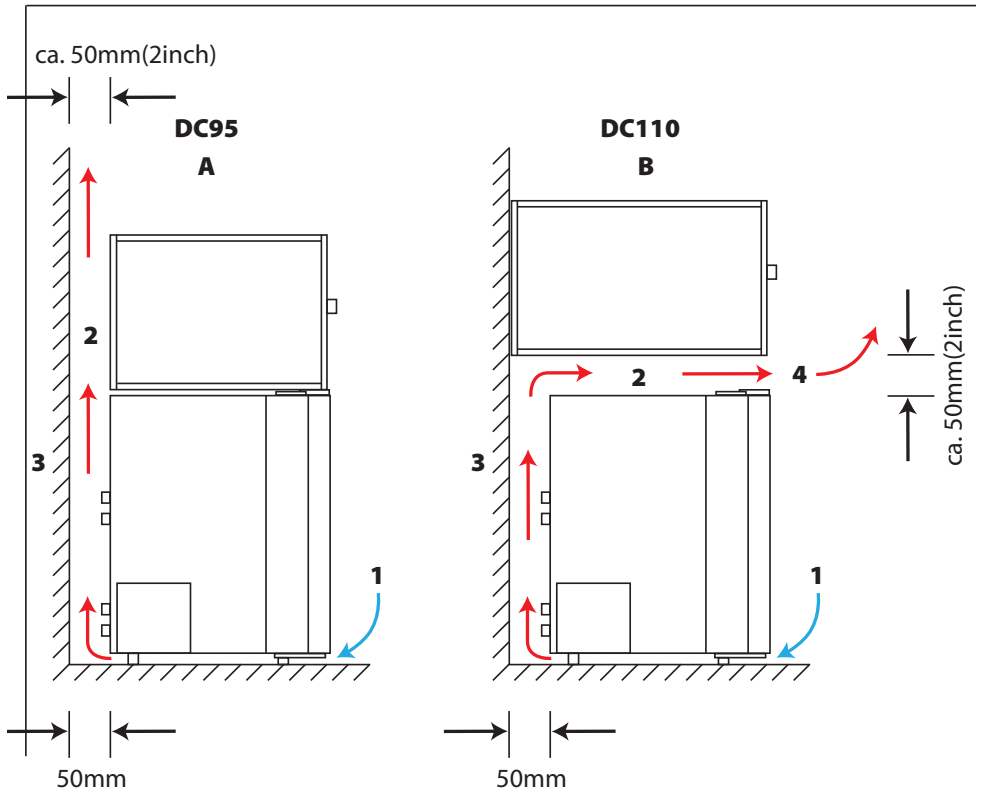

8. Warranty Statement/Terms & Conditions

Nexberg Pty Ltd trading as EvaKool undertakes to the original purchaser that this product is sold free of defect in materials and/or workmanship under normal use for a period of **36 months**. Subject to the following:

- The warranty period commences from the date of purchase by the original purchaser from an authorised EvaKool dealer.
- The Secop compressor in this unit carries a 5 year warranty under normal use.
- EvaKool will honour this warranty on presentation of proof of purchase of the unit to EvaKool or its approved service agent. The service agent may be requested to provide EvaKool with a photocopy of the proof prior to warranty being honoured.
- EvaKool will not be held responsible for any costs incurred in making a warranty claim.
- Please telephone 1300 865 665 for the name of an authorised service agent or refer to list provided on website. It is the purchaser's responsibility to freight the unit to and from the service agent.
- EvaKool will not be held responsible for any damage or loss suffered or cost incurred whilst fridge is in transit.
- Warranty repairs may only be carried out by an authorised service agent. EvaKool will not reimburse repair claims carried out by unauthorised service agents. Any unauthorised tampering with any part of the unit will automatically void the warranty.
- Service agents may charge a fee for viewing or testing the unit. This is not covered by EvaKool or this warranty and is payable at the service point unless authorised by EvaKool.
- Any EvaKool authorised service centre in Australia will be able to carry out the service of your unit. If a repair needs to be undertaken and is covered in terms of this warranty a warranty authorisation number must be obtained prior to commencement of any work.
- This warranty does not extend to any products acquired for the purposes of re-supply, to be used up or transformed in a production or manufacture process or in repairing other goods.
- This fridge is intended for recreational use only. If used for commercial use, a 12 month warranty applies.
- To the extent permitted by law, this warranty does not extend to any claim for damages that you or any other person may have for any loss (including without limitation consequential damages or loss of profit) or damage howsoever caused.
- **EvaKool will not accept a warranty claim if:**
 1. Modifications have been carried out to the unit without EvaKool's written authority.
 2. Damage to or failure of the unit has been caused in EvaKool's opinion by incorrect, extreme or unreasonable use.
 3. Damage to or failure of the unit has been caused in EvaKool's opinion by misuse, neglect, accident, impact or similar cause. Refer the preventative maintenance guidelines.
- EvaKool has total discretion of the variation of the warranty terms.
- Our goods come with guarantees that cannot be excluded under the Australian Consumer Law. You are entitled to a replacement or refund for major failure and for compensation for any other reasonably foreseeable loss or damage. You are also entitled to have the good repaired or replaced if the goods fail to be of acceptable quality and the failure does not amount to a major failure.
- The above warranty conditions are in addition to any other rights and/or remedies as per the applicable law.
- Failure to follow the guidelines/recommendations in this manual may void the warranty.
- This warranty cannot be varied by others.

Please retain your receipt or proof of purchase for warranty purposes.

EVAKOOL®

CHILLED FOR GOOD TIMES

For your nearest stockist contact EvaKool

T: 1300 385 665 (1300 EVKOOL)

E: warranty@evakool.com

or visit us at evakool.com.au