

# EN3DC30 Install guide - Dual charger setup.



**Enerdrive**  
DRIVING YOUR ENERGY NEEDS

**Warning!!**  
A designated Positive (+) & Negative(-) input cables to the DC2DC charger MUST be connected to the engine start battery terminals. Using the vehicle chassis as an earth return is not permitted.  
For late model vehicles fitted with Smart Alternators, the Negative (-) cable must be attached to the "vehicle" side of the alternator sense module.  
Failure to follow these instructions will result in spiking the DC2DC unit and causing the internal input fuses to blow.  
This is not covered under warranty and the fuses are not field serviceable.

## Addendum

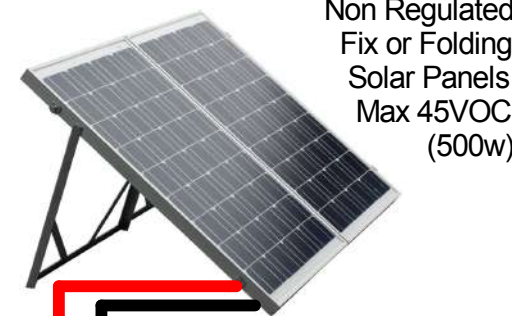

**Warning!! Alternator size**  
Vehicles running Dual DC2DC should have a minimum alternator size of 120Amps. Alternators lower than 120A run the risk of premature failure due to the high load.

Ignition sense for smart alternator vehicles and Dual DC2DC units.  
Also required if start battery has a secondary charge source i.e. Solar, AC Charger

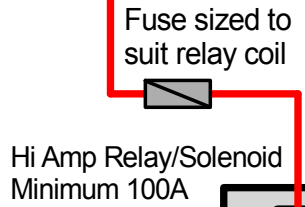

**Please NOTE:**  
The High Amp relay on the Input is required to eliminate excessive loads on the Start battery once the engine is turn OFF.

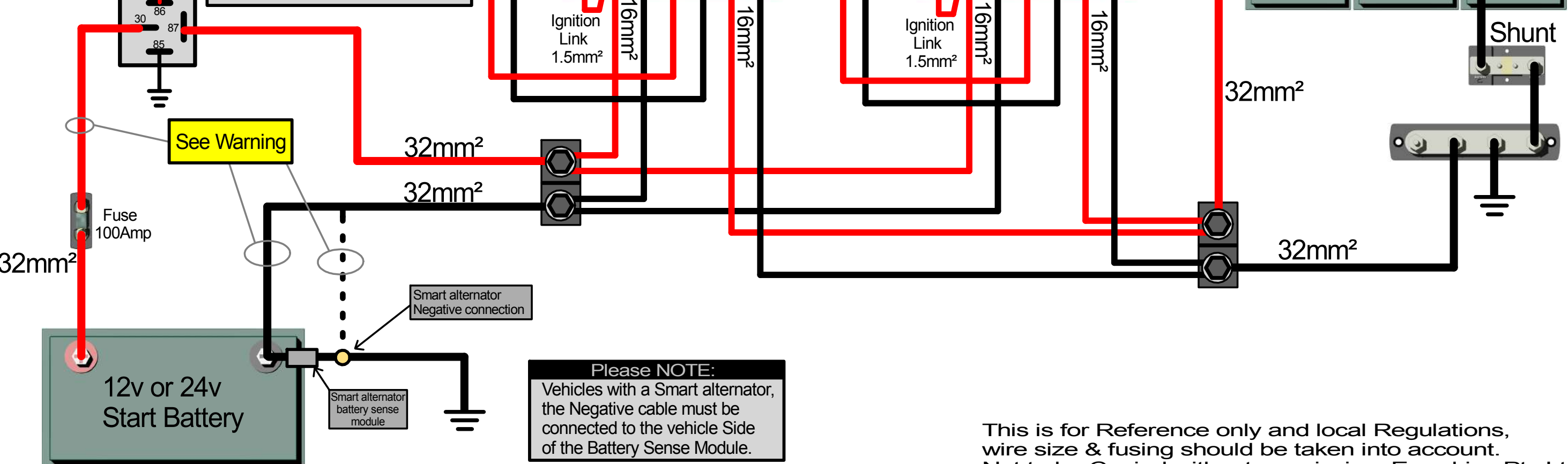

**Please NOTE:**  
Vehicles with a Smart alternator, the Negative cable must be connected to the vehicle Side of the Battery Sense Module.

This is for Reference only and local Regulations, wire size & fusing should be taken into account. Not to be Copied without permission. Enerdrive Pty Ltd