

↗ DOMETIC

REFRIGERATION

RU

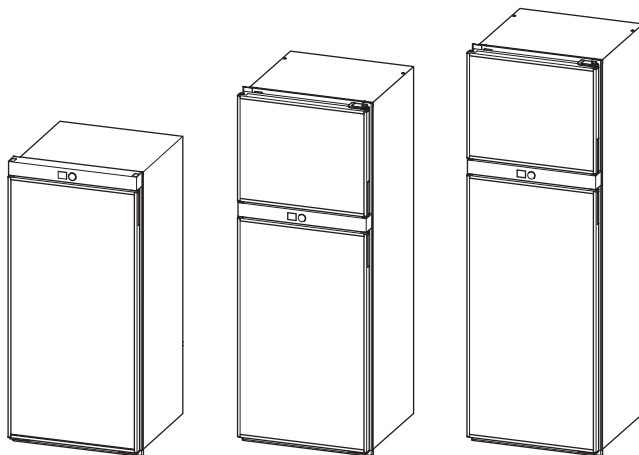

RUA5208X, RUA6408X, RUA8408X

EN

Absorption refrigerator

Installation Manual

© 2020 Dometic Group. The visual appearance of the contents of this manual is protected by copyright and design law. The underlying technical design and the products contained herein may be protected by design, patent or be patent pending. The trademarks mentioned in this manual belong to Dometic Sweden AB. All rights are reserved.

Please read this instruction manual carefully before installation and first use, and store it in a safe place. If you pass on the product to another person, hand over this instruction manual along with it.



NOTE

You can find details on the operation in the operation manual.

Table of contents

1	Explanation of symbols	3
2	Safety instructions	4
3	Scope of delivery	5
4	Accessories	6
5	Intended use	6
6	Installing the refrigerator	6
7	Connecting the refrigerator	22

1 Explanation of symbols



WARNING!

Safety instruction: Indicates a hazardous situation that, if not avoided, could result in death or serious injury.



CAUTION!

Safety instruction: Indicates a hazardous situation that, if not avoided, could result in minor or moderate injury.



NOTICE!

Indicates a situation that, if not avoided, can result in property damage.



NOTE

Supplementary information for operating the product.

2 Safety instructions

The manufacturer accepts no liability for damage in the following cases:

- Faulty assembly or connection
- Damage to the product resulting from mechanical influences and incorrect connection voltage
- Alterations to the product without express permission from the manufacturer
- Use for purposes other than those described in the operating manual



WARNING!

- The electrical installation must comply with national and local regulations including AS/NZS 3001 – Electrical installations.
- The gas installation must comply with national and local regulations including AS/NZS 5601.2 – Gas installations.
- Never open the absorber unit. It is under high pressure and can cause injury if it is opened.
- Ensure clean and residue-free handling if silicone sealant or similar is used. There is a risk of fire if silicone filaments come into contact with hot parts or naked flames.
- Do not operate the refrigerator if it is visibly damaged.
- If the AC power cable for this refrigerator is damaged, it must be replaced by the manufacturer, customer service or a similarly qualified person in order to prevent safety hazards.
- Never use a naked flame to check the refrigerator for leaks.
- This refrigerator may only be repaired by qualified personnel. Inadequate repairs may cause serious hazards.
- Only use universal LPG gas.
- **Only operate the refrigerator** at the pressure shown on the type plate. Only use pressure controllers with a fixed setting which comply with national regulations.
- Dismantle all refrigerator doors for the disposal of the old refrigerator and leave the shelves in the refrigerator to prevent accidental enclosure and suffocation.



CAUTION!

- Danger of crushing! Do not put your fingers into the hinge.
- Before starting the device, ensure that the power supply line and the plug are dry.

**NOTICE!**

- Only hold the refrigerator at the body of the refrigerator during transport. Never hold the refrigerator at the absorber unit, the cooling fins, the gas pipes, the door or the control panel.
- Make sure that the refrigerator circuit is not damaged during transportation. The refrigerant in the refrigerator circuit is highly flammable. In the event of any damage to the refrigerator circuit (smell of ammonia):
 - Switch off the refrigerator if applicable.
 - Avoid naked flames and sparks.
 - Air the room well.
- Do not install the refrigerator near naked flames or other heat sources (heaters, direct sunlight, gas ovens etc.).
- **Danger of overheating!**
Always ensure sufficient ventilation so that the heat generated during operation can dissipate. Make sure that the refrigerator is sufficiently far away from walls and other objects so that the air can circulate.
- Check that the voltage specification on the type plate is the same as that of the power supply.
- Do not open the refrigerant circuit under any circumstances.
- Only use the AC connection cable supplied to connect the refrigerator to the AC mains.
- Only use cables with a suitable size (see chapter “DC power” on page 28).
- Never pull the plug out of the socket by the connection cable.
- The refrigerator must not be exposed to rain.

3 Scope of delivery

Quantity	Description
1	Refrigerator
1	Drain hose
1	Bottom trim piece
1	Sealing strip (fitted underneath during installation)
1	Installation and Operating Manual

4 Accessories

Available as accessories (not included in the scope of delivery):

Description
LS300 ventilation grille
Dometic gas flue kit 3776
RUA5208X only: Door reversing kit
Dometic Roof Vent Kit

All the accessories are available from specialist dealers. If you have any questions, please contact the dealer or your service partner directly.

5 Intended use

The refrigerators are designed for installation in caravans or motorhomes. They are only suitable for cooling and storing foodstuffs. The refrigerators are not intended for the proper storage of medicine.

The refrigerators are designed to be operated on a DC power supply, AC mains power supply or universal LPG gas.

6 Installing the refrigerator

6.1 Preparing the installation

When installing the refrigerator, note the following:

- Ensure that the floor is solid and level.
- Ensure that the refrigerator is level.
- The refrigerator must be installed so that it is easily accessible for service work, easy to uninstall and install and can be easily removed from the vehicle.

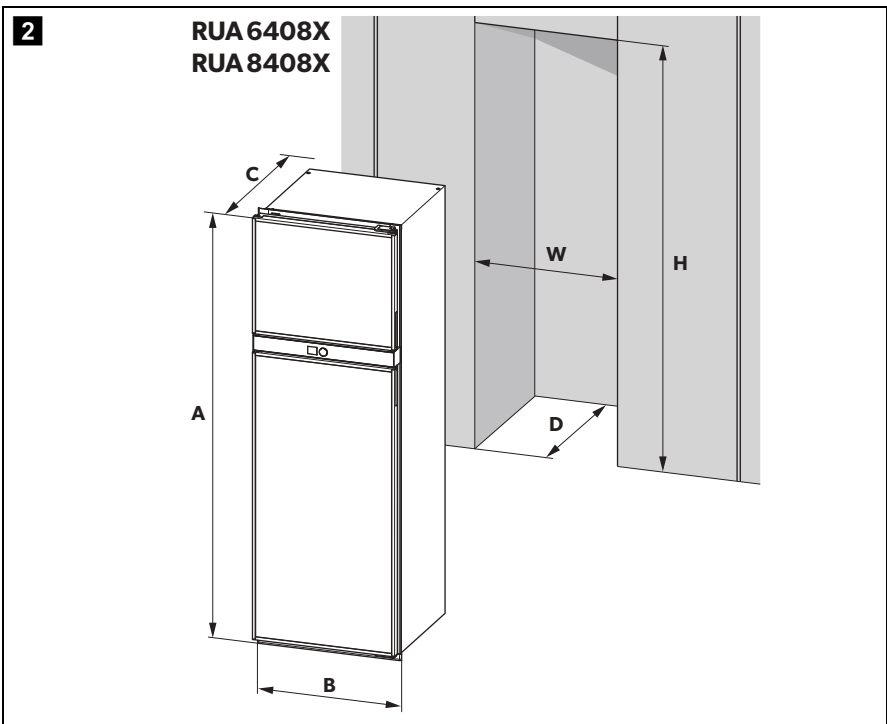
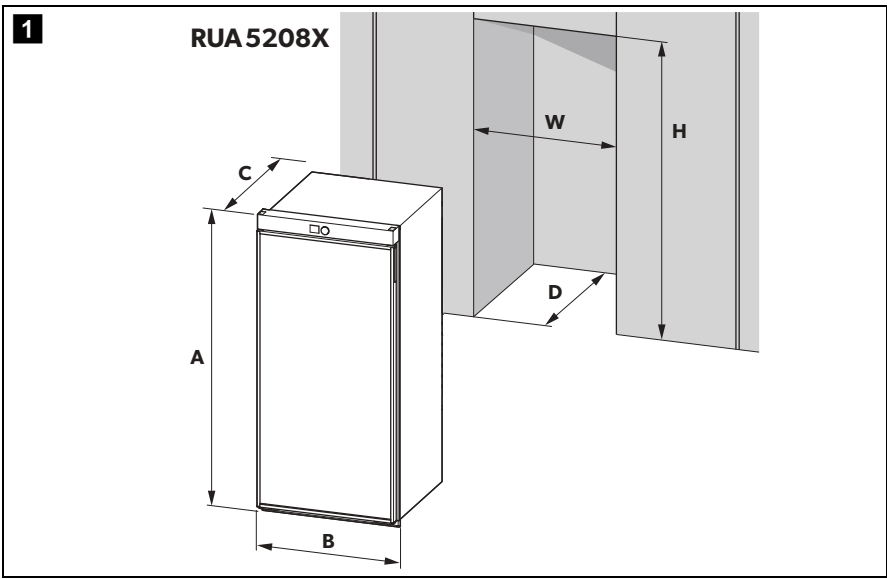

- The refrigerator must be installed in a recess so that it stands secure when the vehicle is in motion. Note the following dimensions (fig. 1 and fig. 2):

	RUA 5208X	RUA 6408X	RUA 8408X
Refrigerator	Overall dimension in mm		
Height (A)	1191	1447	1657
Width (B)	550	550	550
Depth (C) (excludes control knob 5mm)	677	677	677
Recess	Dimension in mm		
Height (H)	1181 – 1186	1437 – 1442	1647 – 1652
Width (W)	530 – 535	530 – 535	530 – 535
Depth (D)	min. 621	min. 621	min. 621

Installation with two side vents

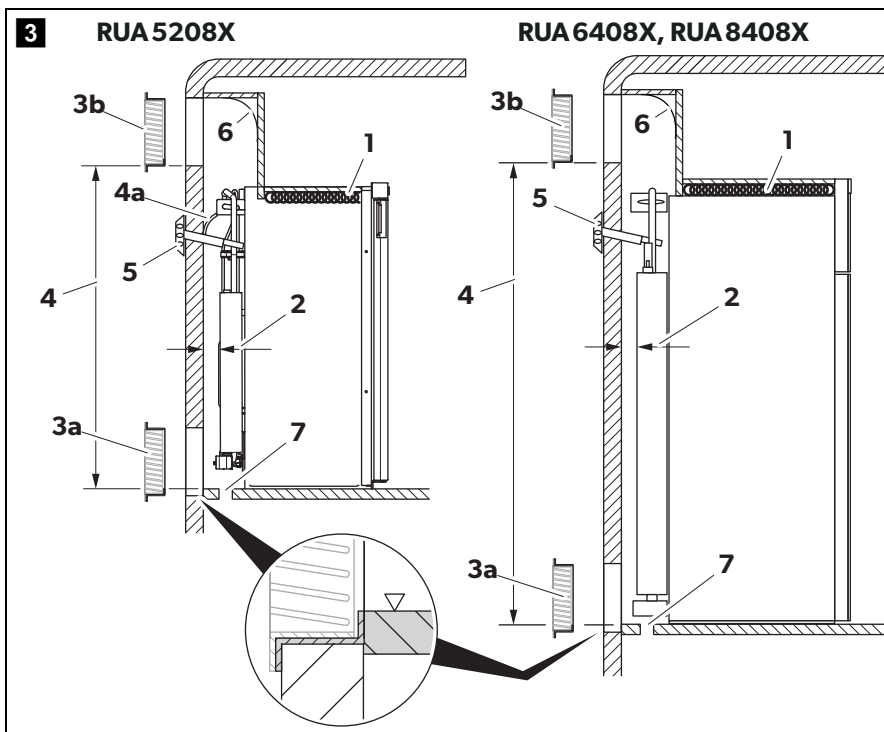

Pos. in fig. 3	Description
1	Insulation wool on top and sides of cabinet
2	Clearance minimum 10mm to maximum 25mm
3	LS300 ventilation grille
4	Recommended height is equal to the height of the cabinet RUA 5208X only: If the vehicle's design does not allow you to install the top exhaust vent above the cabinet then the minimum permitted height is 935 mm from the bottom of the refrigerator.
4a	Air deflection plate must be installed to direct airflow into the condenser fins if top vent height is lower than the top of the refrigerator cabinet.
5	Dometic gas flue kit 3776
6	Air deflection plate
7	Gas escape hole, min. 40 mm – required if lower air vent would not permit all leaked gas to escape

- The outer wall must be fitted with one air inlet ventilation grille (fig. **3** 3a, page 8) and one outlet ventilation grille (fig. **3** 3b, page 8) so that the heat generated can be easily released to the outside:
 - Lower air inlet vent LS 300 must be installed flush with the lowest opening of the grill flush with the floor of the refrigerator.
 - Upper air outlet vent LS 300 must be installed with the bottom of the vent no lower than equal to the top of the refrigerator cabinet, the bottom of the top vent can be higher than the cabinet (RUA5208X only: minimum permitted height is 935mm from the bottom of the refrigerator).
- Fit an air deflection plate (fig. **3** 6, page 8) above the condenser so that the heat does not accumulate in the vehicle.
- Put insulation wool (fig. **3** 1, page 8) on top and sides of the cabinet.
- If the lower ventilation grille of the air inlet vent cannot be installed flush to the floor, a gas escape hole (fig. **3** 7, page 8 and fig. **12**, page 15) must be provided in the floor for releasing any possible gas leakage.
- The distance between the refrigerator and the rear wall must be at least 10 mm and at most 25mm.

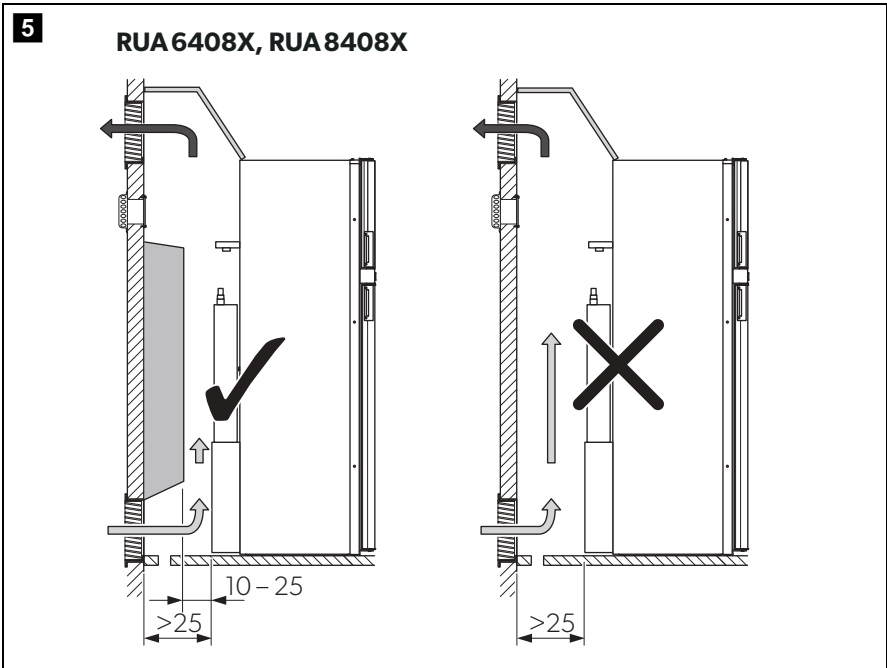
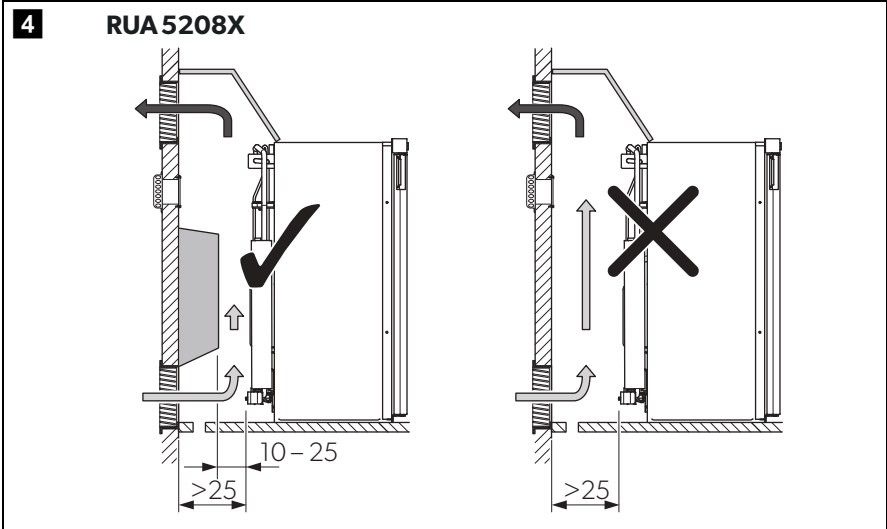

- The recommended maximum distance between the refrigerator and the rear wall is 25 mm. A distance of more than 25 mm between the refrigerator and rear wall leads to poor performance and increases the power consumption of the refrigerator. Reduce the space behind the refrigerator to maximum 25 mm to create adequate air inlet and outlet ventilation corridor (fig. 4 and fig. 5). Use a ventilation plate, for example, to do this.

Installation with one lower side vent and one roof vent

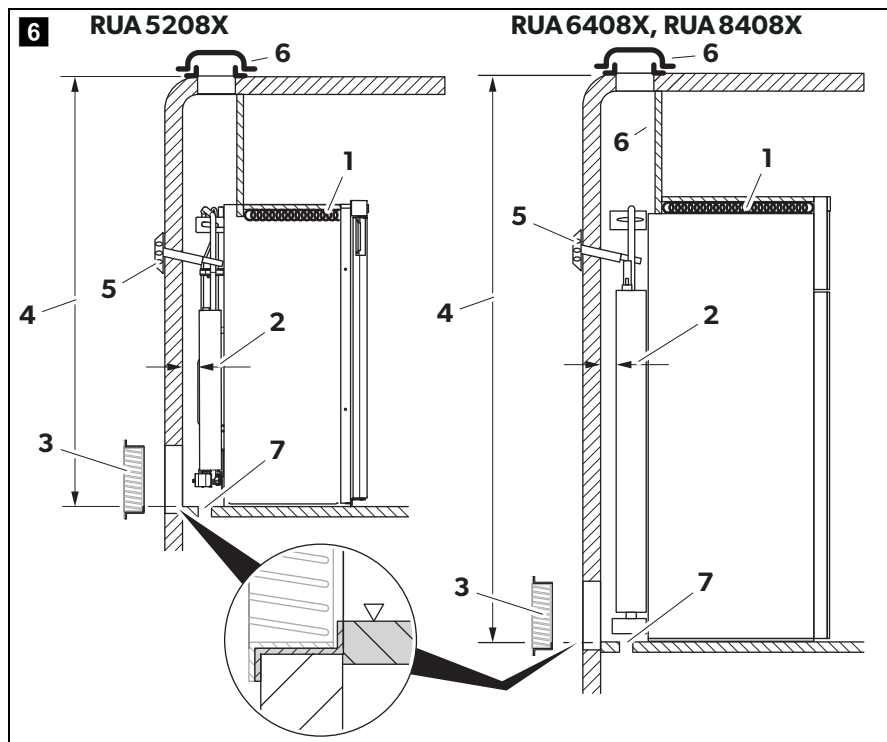

Pos. in fig. 6	Description
1	Insulation wool on top and sides of cabinet
2	Clearance minimum 10mm to maximum 25mm
3	LS300 ventilation grille
4	Minimum height is equal to the height of the cabinet plus 150 mm
5	Dometic gas flue kit 3776

Pos. in fig. 6	Description
6	Roof vent
7	Gas escape hole, min. 40 mm – required if lower air vent would not permit all leaked gas to escape

- If the minimum distance between the air inlet and outlet vents cannot be met, a roof vent must be installed instead of the air outlet vent.
 - The roof vent should be installed directly above the back of the refrigerator as far as this is possible. Use an air duct if you need to install the roof vent (fig. **6** 6) offset, otherwise heat will accumulate there.

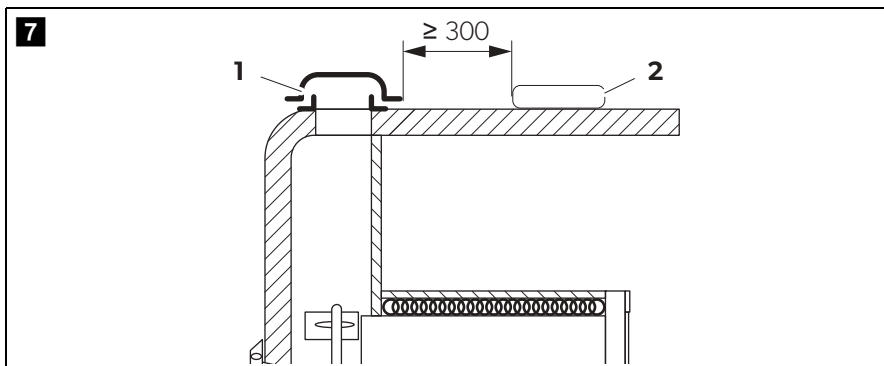

- If a roof air conditioner is installed, the distance between the roof vent (fig. **7** 1) and the air outlet of the roof air conditioner (fig. **7** 2) must be at least 300 mm.
- The refrigerator must not be installed at the side of the air inlet and outlet vents as this leads to poor performance and increases the power consumption of the refrigerator.
- The air inlet and outlet vents must not be covered by vehicle parts (such as an open door or by installing accessories such as bicycle racks) while operating.
- A separate flue duct must be installed under the air outlet vent, see chapter "Installing the flue duct" on page 19.
- Install the refrigerator so that it is protected from excessive heat, as this leads to poor performance and increases the power consumption of the refrigerator.
- The electrical installation must comply with national and local regulations including:
 - AS/NZS 3001
- The gas installation must comply with national and local regulations including:
 - AS/NZS 5601.2 – Gas installations – LP Gas installations in caravans and boats

- The refrigerator must be installed in a draught-proof location, see chapter “Installing the refrigerator in a sealed location separate to the living space” on page 13.

6.2 Installing the refrigerator in a sealed location separate to the living space

Gas-powered refrigerators in caravans or motorhomes must be installed in a sealed location. This means that the combustion air can not be extracted from the interior and exhaust fumes are prevented from directly entering the living space.

A suitable seal must be provided and fitted between the rear wall of the refrigerator cabinet and the interior of the vehicle. The purpose is to provide a seal between the interior of the vehicle and the cooling unit and ventilation area behind the refrigerator.



WARNING! Fire hazard!

Do not use flammable materials for the draught-proof installation.

The manufacturer has applied a sealing strip to the rear surface of the front frame.

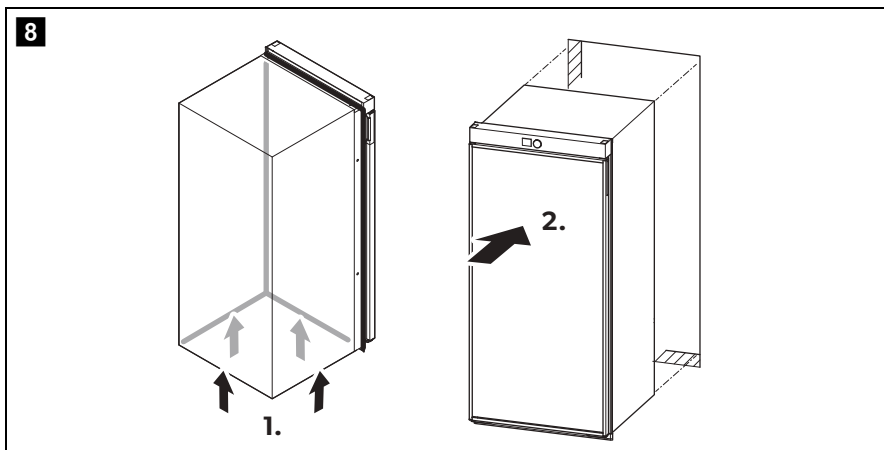

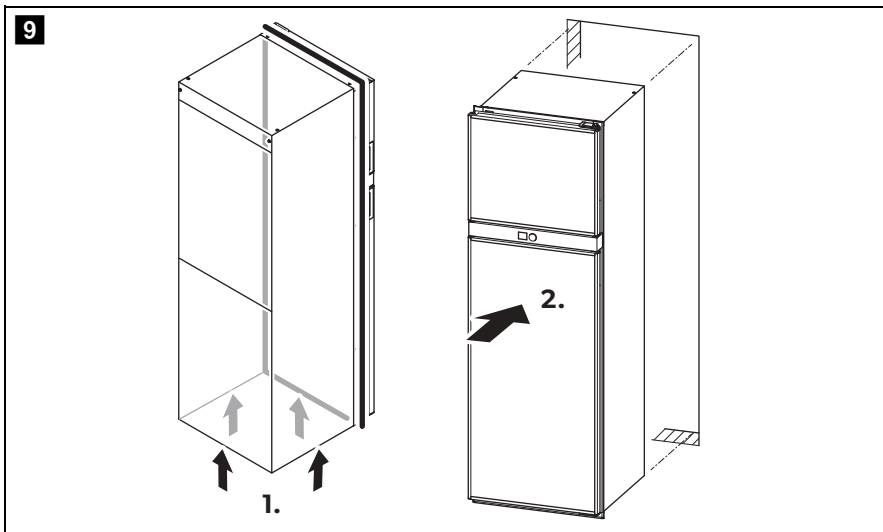

- Apply the sealing strip to all four sides of the bottom surface of the refrigerator (step **1.** in fig. **8** and fig. **9**).
- Push the refrigerator into position (step **2.** in fig. **8** and fig. **9**). This then seals the space behind the refrigerator to the interior of the vehicle.

OPTIONAL:

- If the refrigerator stands on a platform, install the bottom trim piece in order to seal the space between the refrigerator and the platform.

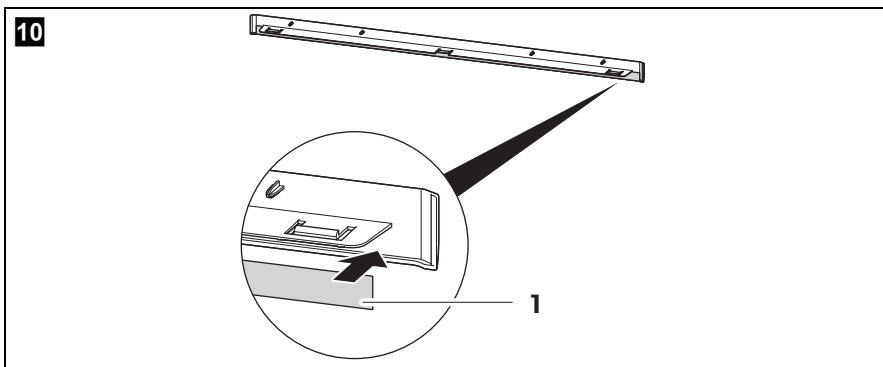

- A sealing strip (fig. **10** 1) is applied to the lower surface of the bottom trim piece.

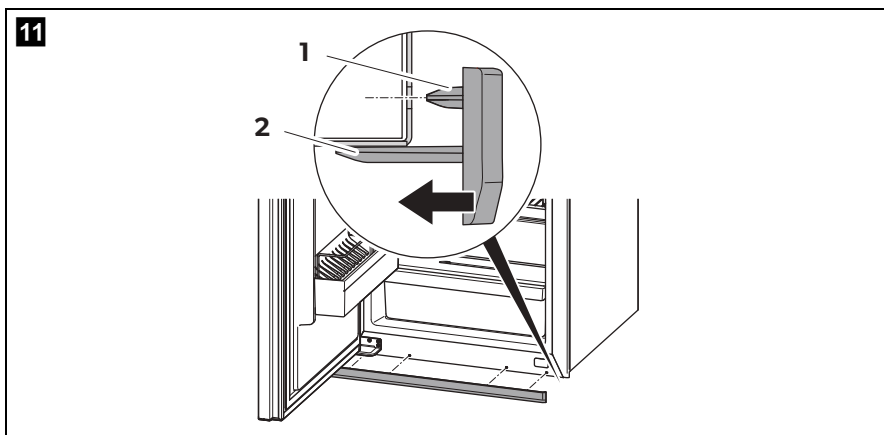

- Push the bottom trim piece with the four plugs (fig. **11** 1) into the holes on the front frame of the refrigerator.
- Snap the three catches (fig. **11** 2) into the holes under the bottom frame of the refrigerator.

6.3 Making air inlet and outlet vents



NOTE

At high ambient temperatures, the refrigerator can only provide its maximum cooling capacity if the optimum ventilation has been provided.

- ▶ Make a cut out in the wall to fit the LS 300 for the upper and lower vent system, see chapter “Preparing the installation” on page 6.
- ▶ If the lower ventilation grille cannot be installed with the lowest opening of the grill flush with the floor of the refrigerator, make a gas escape hole in the floor (fig. **12**, page 15) so that all unburnt gas will escape.

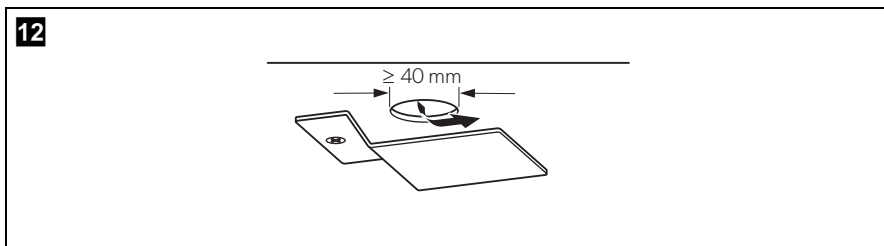

- ▶ Shield the opening with a deflector to prevent sludge or dirt from getting inside while driving (fig. **12**).

If you have to use a roof vent instead of an upper wall vent:

- ▶ Cut out a section in the roof. Refer to the roof vent instruction manual for the required dimensions. When doing so, observe the information, see chapter “Preparing the installation” on page 6.

6.4 Installing the drain water hose

- ▶ To avoid damage on the drain water hose, position the hole for the drain water hose in a way, that the hose does not touch the boiler casing.
- ▶ Drill a hole through the floor at the rear of the refrigerator.
- ▶ Install the drain water hose through the drilled hole. Ensure, that the drain water hose is long enough in order to drain the water outside of the vehicle.
- ▶ Ensure that the drain water hose is not kinked.
- ▶ Seal the area around the drain water hose.

6.5 Installing the ventilation grille

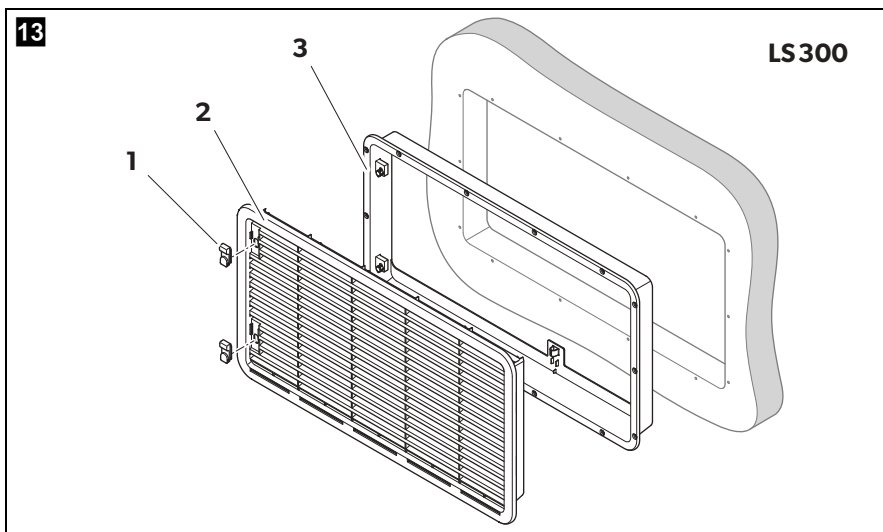

No. in fig. 13	Description
1	Slider
2	Ventilation grille
3	Installation frame

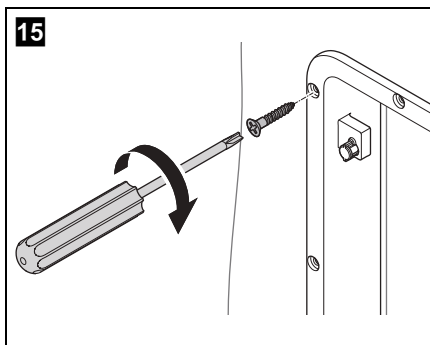
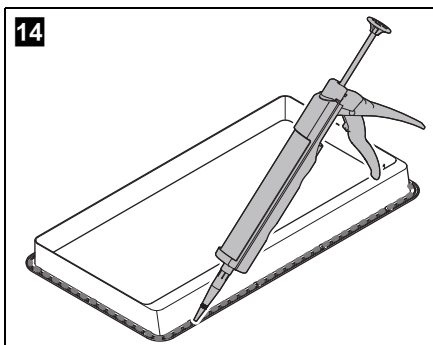

- ▶ Ensure the installation is water resistant (fig. 14).
- ▶ Insert the installation frame and screw it down tightly (fig. 15). Use all fixing holes.

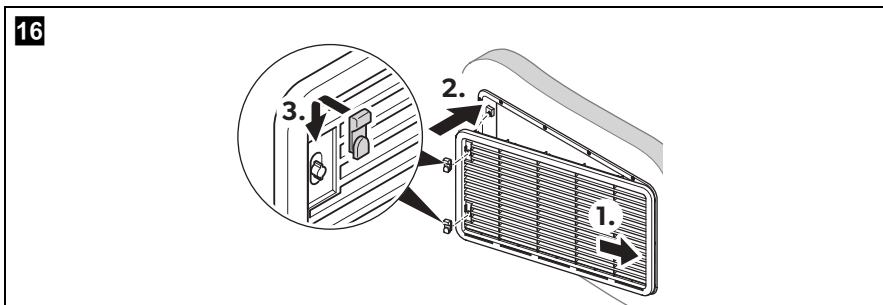

- ▶ Fit the ventilation grille (step 1. and step 2. in fig. 16).
- ▶ Insert the slider and lock the ventilation grille with it (step 3. in fig. 16).

6.6 Install the roof vent

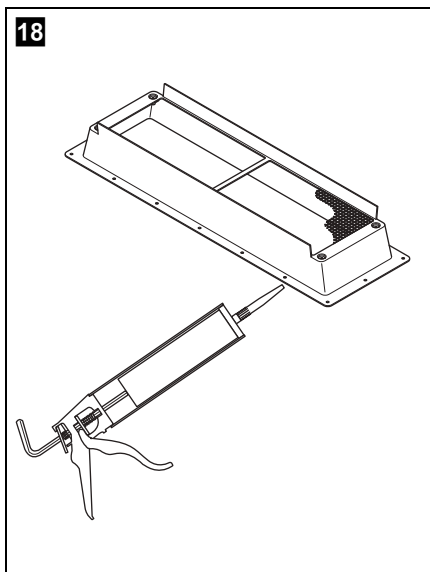
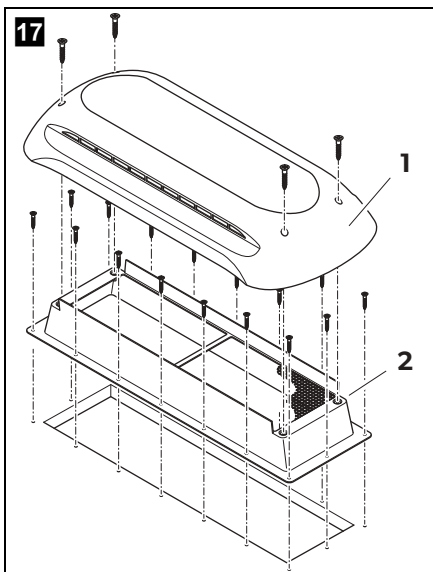

No. in fig. 17	Description
----------------	-------------

1	Hood
---	------

2	Installation frame
---	--------------------

► Ensure the installation is water resistant (fig. 18).

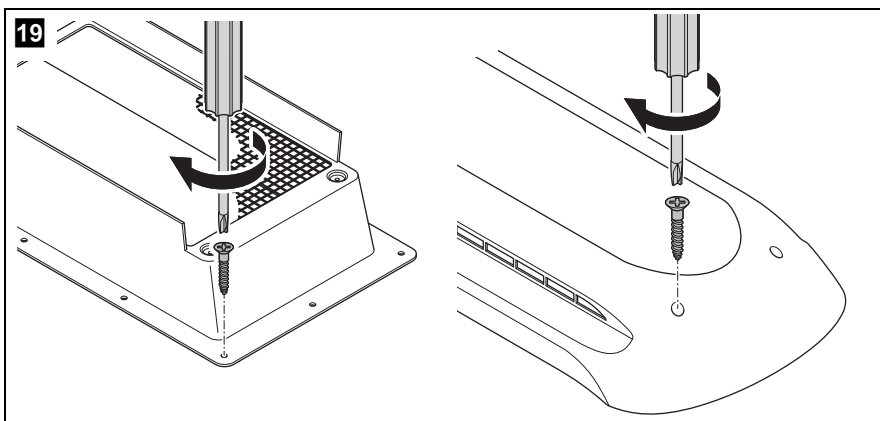

► Insert the installation frame and screw it down tightly (fig. 19 1). Use all the fixing holes for this.

- Insert the hood and screw it down tightly (fig. 19 2).

6.7 Installing the flue duct

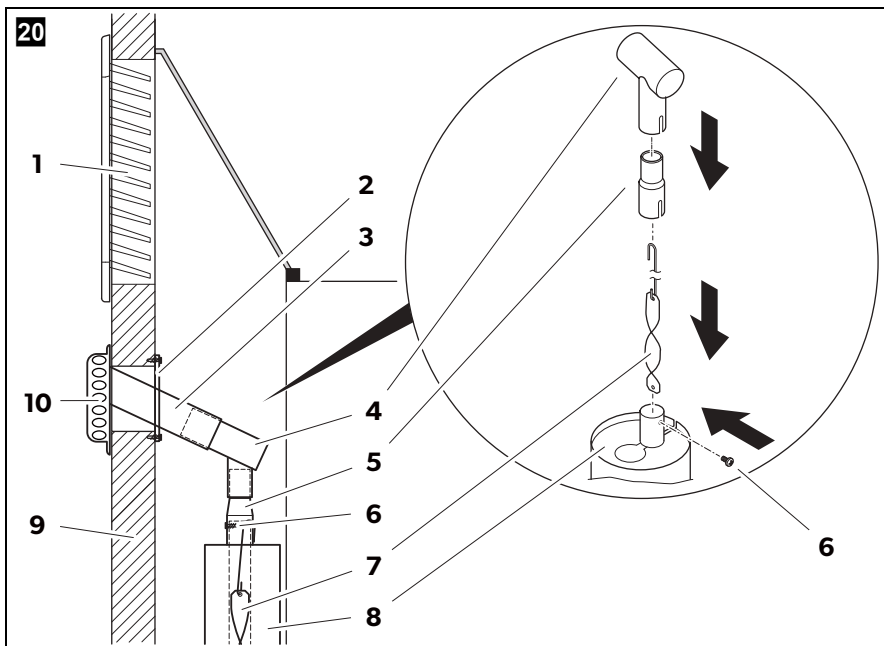

NOTE

- Install the Dometic gas flue kit 3776.
- It is not recommended to install additional flue stacks, as this leads to poor performance and increases the power consumption of the refrigerator.
- If a flue extension is used it must have no more than 2 bends, have minimum rise of 35 degrees above horizontal, be as short as practicable, designed to prevent leaks, and be constructed from appropriate materials in accordance with AS/NZS 5601.2.
- Mount the flue duct under the upper ventilation grille (fig. 20 1).

Install the flue duct as follows:

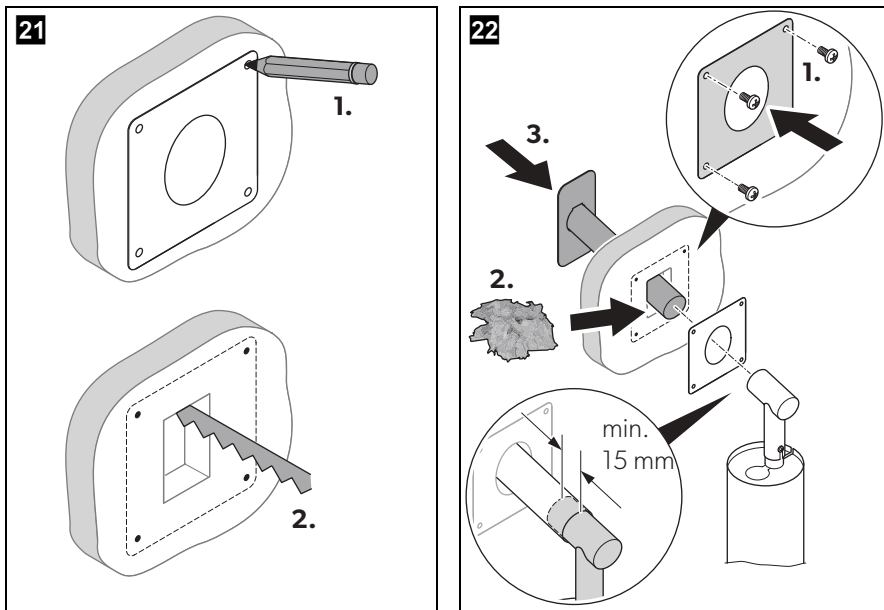

- ▶ Make a rectangular opening in the outer wall of the vehicle (fig. **21**).
 - The opening must be as wide as the flue pipe (fig. **20** 3, page 19).
 - The opening must be high enough that the flue pipe fits through at a 45° angle.
- ▶ Insert the coil (fig. **20** 7, page 19) in the flue pipe (fig. **20** 8, page 19) of the refrigerator.
- ▶ Place the T-piece (fig. **20** 4, page 19) on the adaptor (fig. **20** 5, page 19) and the flue pipe (fig. **20** 8, page 19) of the refrigerator.
- ▶ Direct the T-piece at an angle of 45° towards the rear wall.
- ▶ Attach the T-piece, adaptor and flue pipe with a screw (fig. **20** 6, page 19).
- ▶ Install the mounting plate (fig. **22**).
- ▶ Fill the opening with fire-resistant material (e.g. stone wool (fig. **22**)).



NOTE

In some installation situations, it is possible that the flue pipe would extend too far out of the vehicle in its installed state. Shorten the flue pipe to the correct length if necessary.

- ▶ Slide the flue pipe at least 15 mm on the T-piece (fig. **22**).

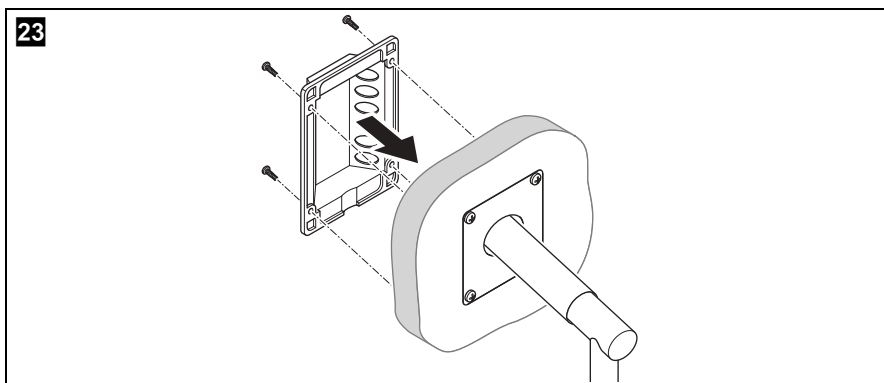

- ▶ Attach the cover for the flue stack outside on the vehicle (fig. **23**).

6.8 Securing the refrigerator



CAUTION!

Only screw through the bushes built into the refrigerator, otherwise foamed components, including electrical wiring, can be damaged.



NOTE

Ensure that the screws are tight, to prevent them coming loose when under increased loads (while driving).

- ▶ Push the refrigerator firmly into its final location with the front flange sitting hard against the recess front.

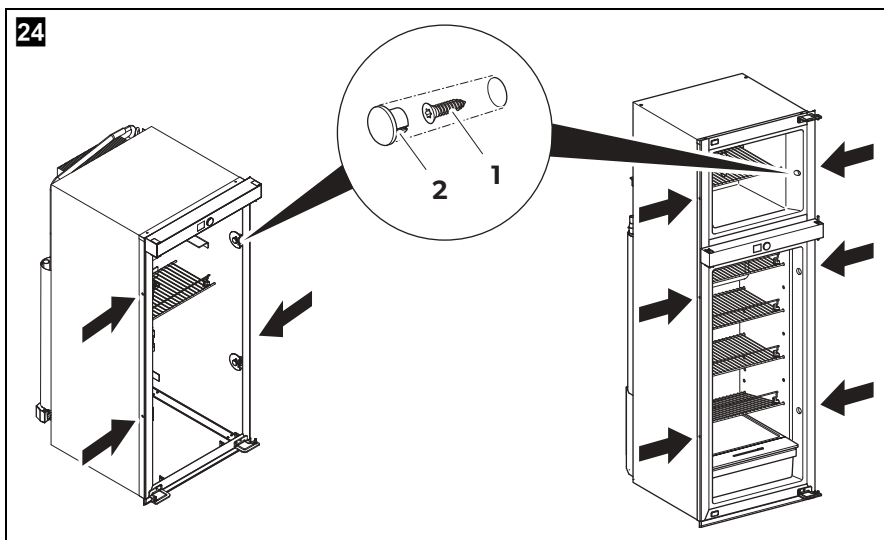

- ▶ Push the screws (fig. 24 1) through the plastic bushes in the sides of the refrigerator, and fasten into the recess walls.
- ▶ Fit the caps (fig. 24 2) into the bushes.

7 Connecting the refrigerator

7.1 Connecting to the gas supply



NOTICE!

- This refrigerator may only be connected to the gas supply by a specialist in accordance with the applicable guidelines and standards.
- Only use cylinders of universal LPG gas fitted with an approved gas pressure regulator. Compare the pressure information on the data plate with the pressure information on the pressure regulator on the gas cylinder.
- **Only** operate the refrigerator at the pressure shown on the data plate.
- **Only** operate the refrigerator with the type of gas shown on the data plate.
- Please note the pressures which are permitted in your country. Only use pressure controllers with a fixed setting which comply with the national regulations.

**NOTE**

The pressure of the gas supply must be 2.75 kPa. Check the pressure at the test point before using the refrigerator (fig. **25** 1, page 23).

It must be possible to shut off the refrigerator from the gas line separately by means of a shut-off device. The shut-off device must be easily accessible.

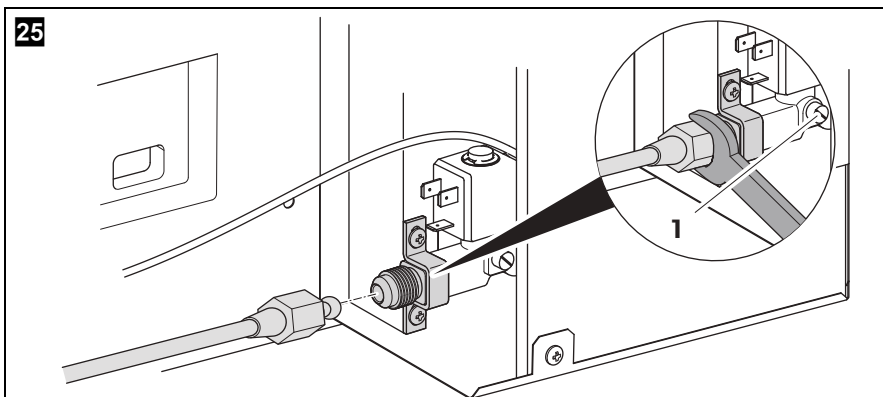

- ▶ Connect the refrigerator securely to the gas supply (fig. **25**). Always use a back up wrench when loosening and tightening connections.
- ▶ Have a leak test and a flame test performed by an authorised specialist after professional installation. Ensure you are issued with a certificate of inspection.

7.2 Connecting the device to electrical power supply

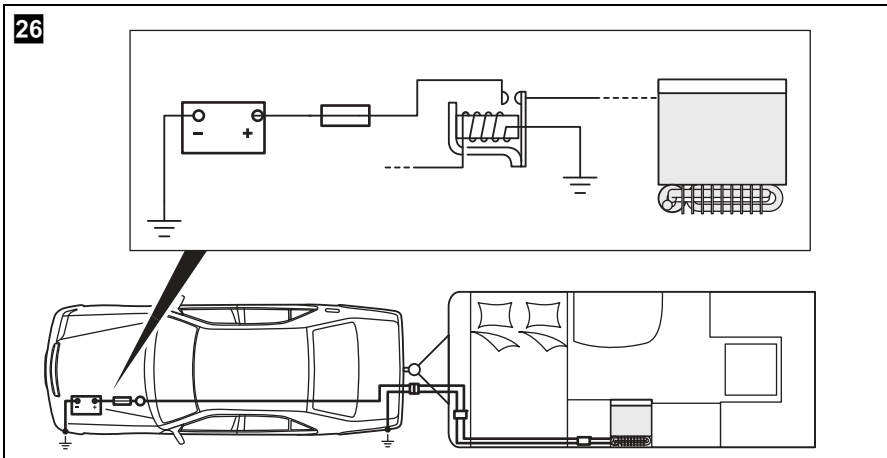

NOTICE!

- The electrical installation and repairs may only be performed by a specialist in accordance with the applicable regulations and standards.
- The device can be connected to 12 V DC and 230 – 240 V AC power supply.
- The respective negative and positive cables of the DC connections for heating and controls may not be joined with one another in a caravan. This can cause electrical interference or damage to electrical components.
- DC connection to the heating element must be made to the vehicle engine battery, connection only while engine is running (fig. **26**).



NOTE

- The mains socket must be readily accessible so that you can unplug the power cord if required, thereby disconnecting the refrigerator from the power.
- The plug of the AC connection cable must not be cut off.
- The connection cables must be laid so that they do not come in contact with hot parts of the unit/burner or with sharp edges.
- Changes to the internal electrical installation or the connection of other electrical components (e.g. extra third party fans) to the internal wiring of the refrigerator will void any claims from the guarantee and product liability.

► Connect the device as follows:

RUA5208X

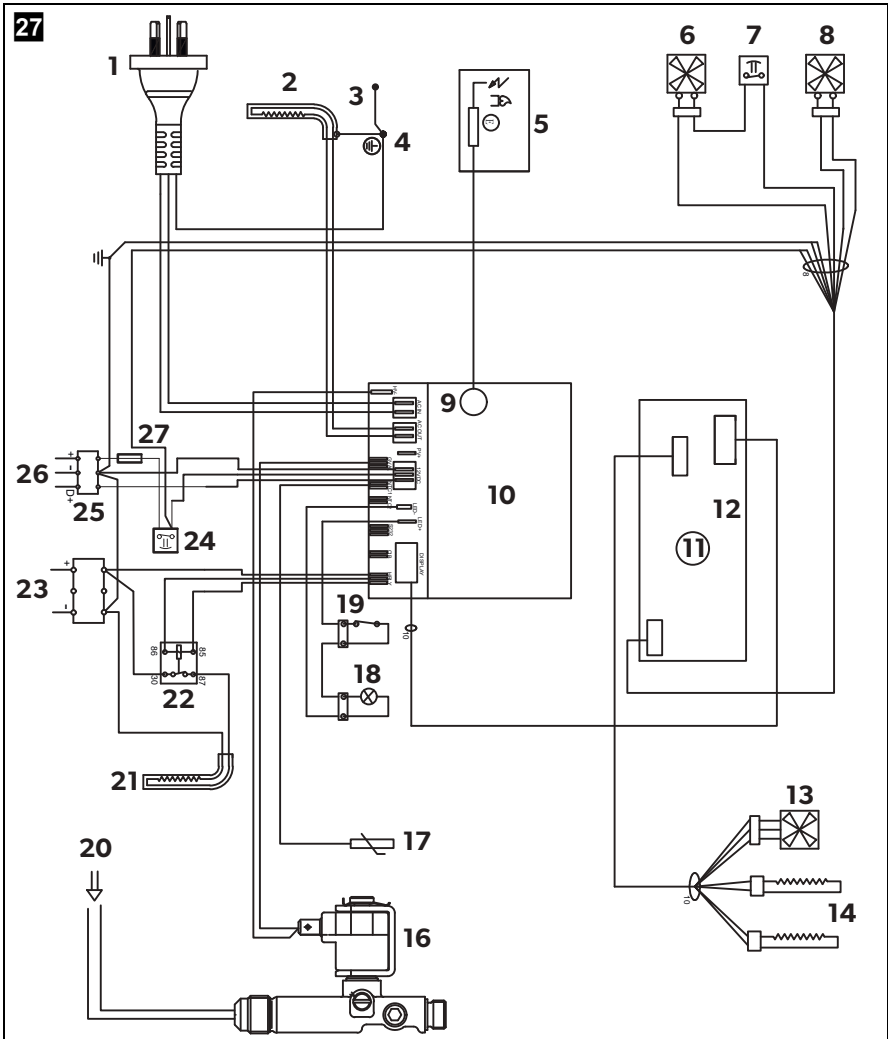

RUA6408X, RUA8408X

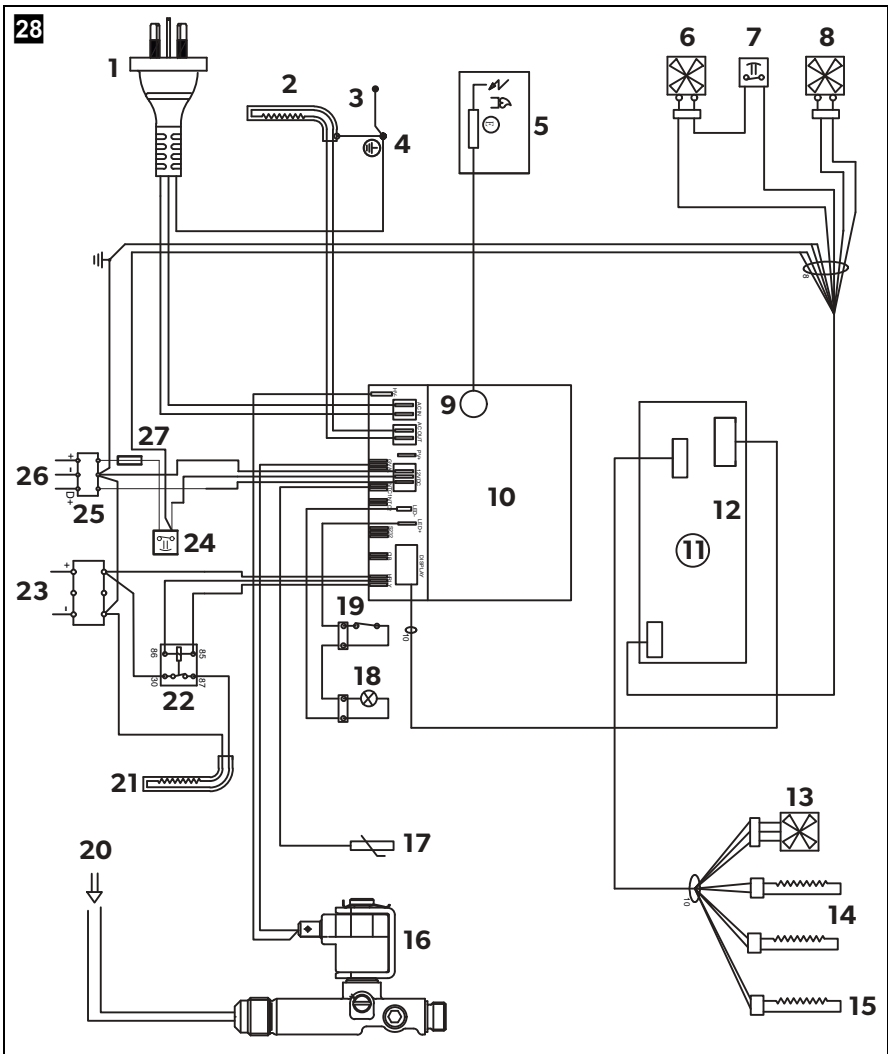

Item	Description
1	Connection cable for AC connection
2	Heater 240 V AC
3	Earth for CU
4	Protective Earth

Item	Description
5	Electrode
6	Outer fan 1
7	Fan thermostat
8	Outer fan 2
9	Ignition port
10	Power module
11	Control button
12	Display
13	Inner fan
14	LAC and defrost heater
15	Frame heater (RUA6208X, RUA8408X only)
16	Gas valve
17	Temperature sensor
18	Lamp
19	Door sensor
20	Gas inlet
21	12 V DC heater
22	Relay
23	12 V DC vehicle battery connection
24	Thermostat
25	D+ to alternator connection
26	12 V DC house battery connection
27	Thermofuse

AC power

- Connect the refrigerator with the mains plug to an AC socket.

DC power

Please note the following cable sizes:

- 12 V DC vehicle battery connection: $\geq 10 \text{ mm}^2$
 - 12 V DC house battery connection: $\geq 1 \text{ mm}^2$
 - Connection D+: $\geq 0.5 \text{ mm}^2$
 - Total cable length: max. 8 m
- ▶ Protect the DC power supply for the 12 V DC heater with 30 A fuse.
 - ▶ Protect the DC power supply for controls with 3 A fuse.
 - ▶ Run cables to the heating element via a relay or suitable means controlled by an ignition switch to prevent battery from completely discharging, if the engine is switched off (fig. **26**, page 24).
 - ▶ Connect vehicle battery cables to the respective plus and minus terminal (fig. **27** 23, page 25).
 - ▶ Connect house battery cables to the respective plus and minus terminal (fig. **27** 26, page 25).

D+

In automatic mode, the refrigerator selects the most favourable mode available. The refrigerator is only operated with DC power when the vehicle engine is running. The electronics of the refrigerator uses the signal D+ from the vehicle alternator to detect the running engine.

- ▶ Connect the D+ connection to the controls (fig. **27** 25, page 25) with the respective terminal of the vehicle.

7.3 Alternative connection methods for DC power supply

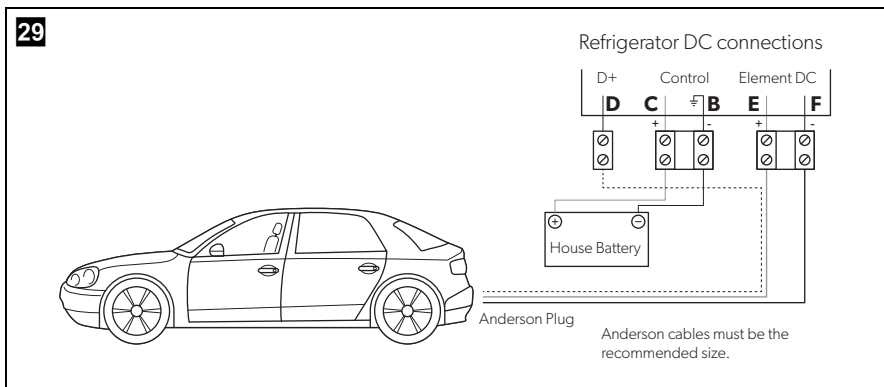

Connection to suit motor home or caravan with the D+ wire connected to the vehicle alternator or ignition switch.

No house battery recharging from the vehicle.

The D+ connection is taken to the vehicle alternator.

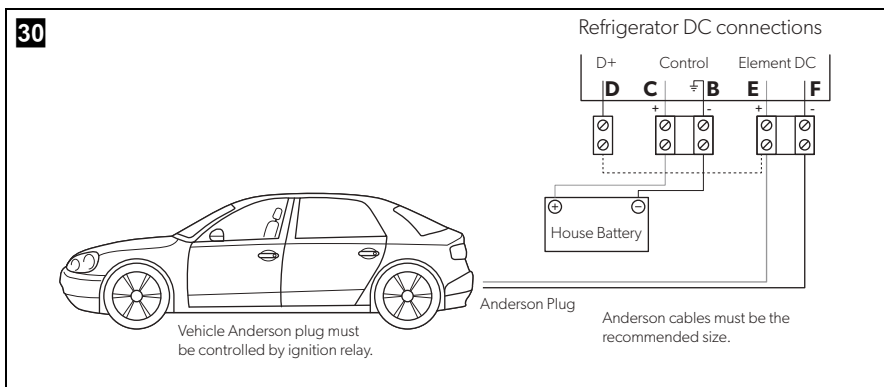

Anderson plug controlled by vehicle relay to the ignition switch. Power can only be supplied if the engine is running.

No house battery recharging from the vehicle.

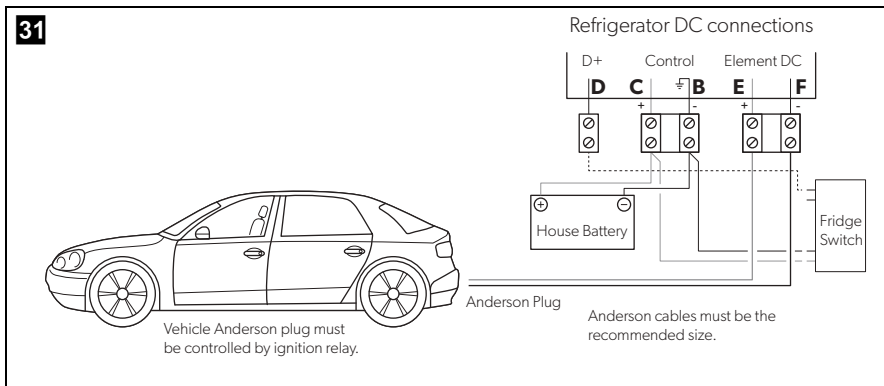

Using a fridge movement switch to add 12 V $\overline{=}$ to the D+ connection wire, only when the vehicle is moving.

No house battery recharging from the vehicle.

The D+ is turned on and off via an optional fridge movement switch.

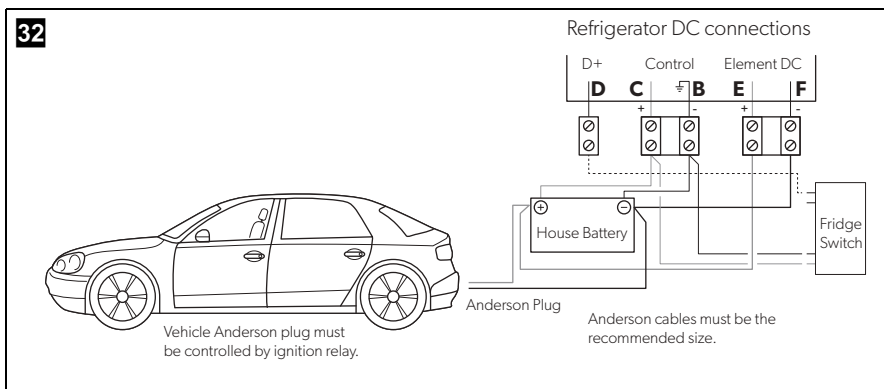

Using a fridge movement switch to add 12 V $\overline{=}$ to the D+ connection wire, only when the vehicle is moving. The Anderson plug connection must keep the house battery fully charged.

House battery recharged by vehicle.

The D+ is turned on and off via an optional fridge movement switch.

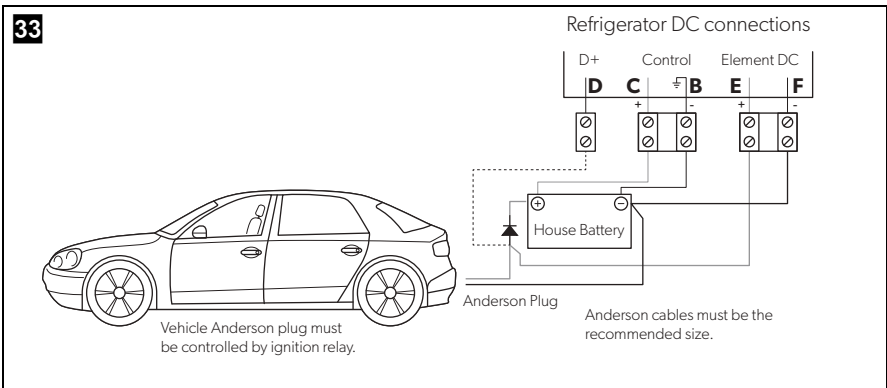

Anderson plug recharging the house battery via a power diode. The D+ wire can only get a 12 V signal when the battery is being charged.

House battery recharged by vehicle.

The D+ is turned on and off by the vehicle starting and stopping.

Mobile living made easy.



dometic.com

**YOUR LOCAL
DEALER**

dometic.com/dealer

**YOUR LOCAL
SUPPORT**

dometic.com/contact

**YOUR LOCAL
SALES OFFICE**

dometic.com/sales-offices

A complete list of Dometic companies, which comprise the Dometic Group, can be found in the public filings of:
DOMETIC GROUP AB Hemvärnsgatan 15 SE-17154 Solna Sweden