

DEWALT®

www.DEWALT.com

**DXGC4150i
DXGC8250i
DXGC8250Ei**

DXGC4150i

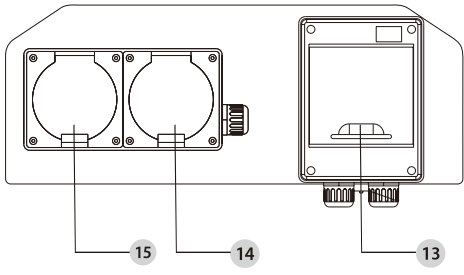

DXGC8250i

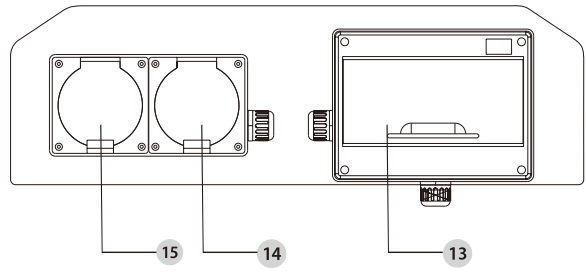

DXGC8250Ei

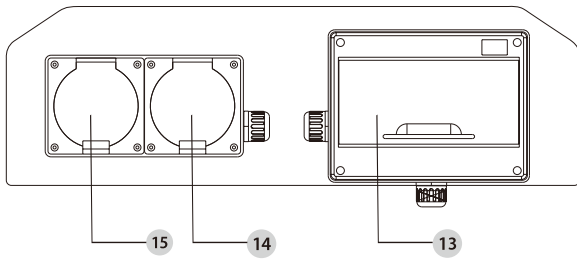

Fig. C

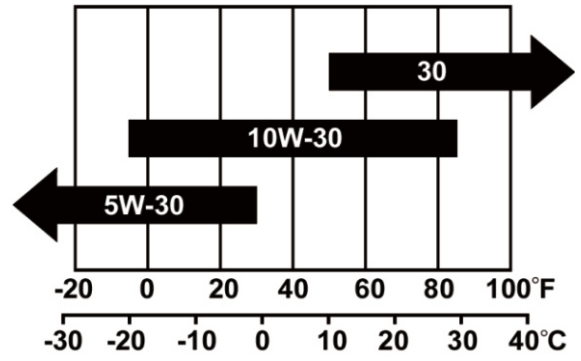
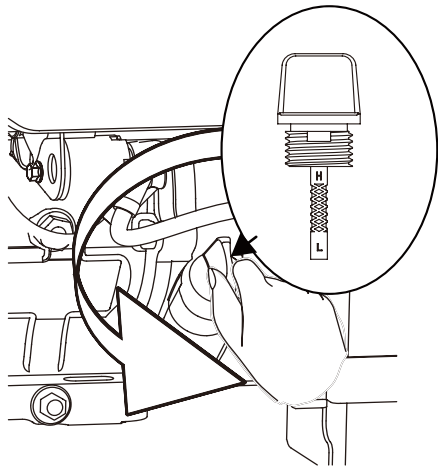

Fig. D

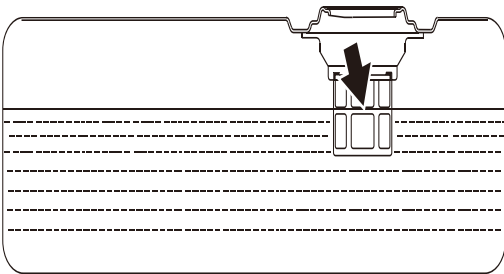

Fig. E

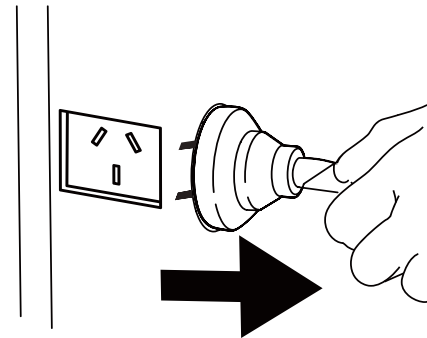

Fig. F

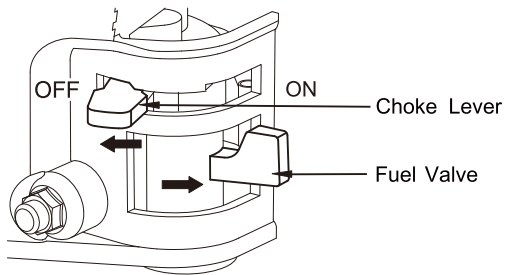

Fig. G

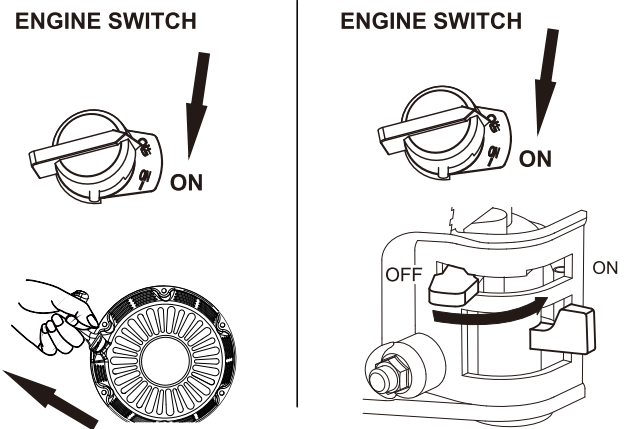

Fig. H

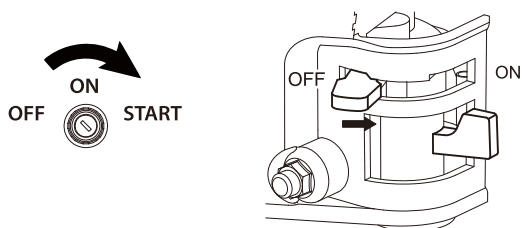

Fig. I

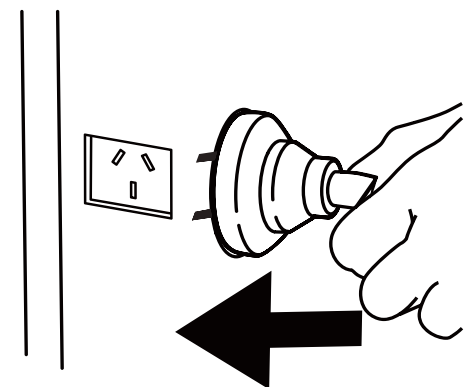

Fig. J

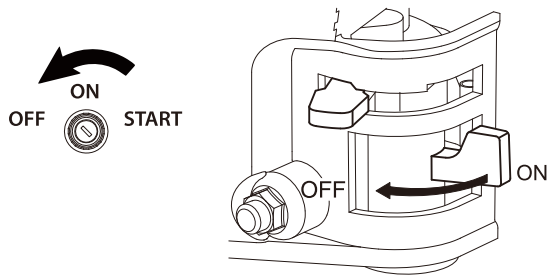

Fig. K

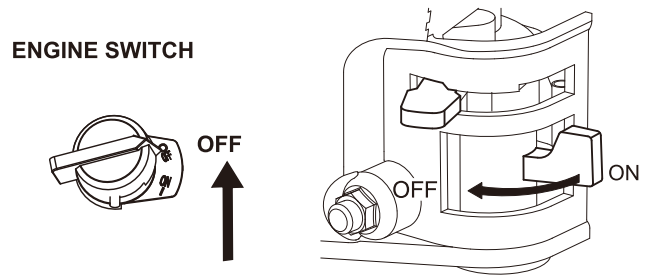

Fig. L

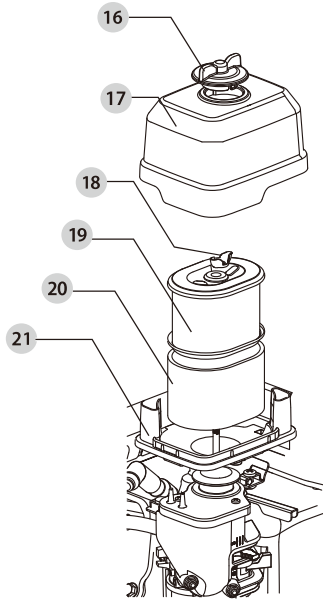

Fig. M

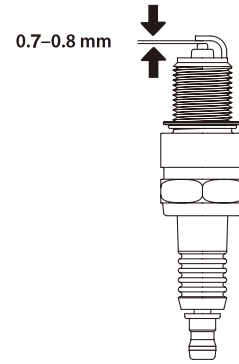
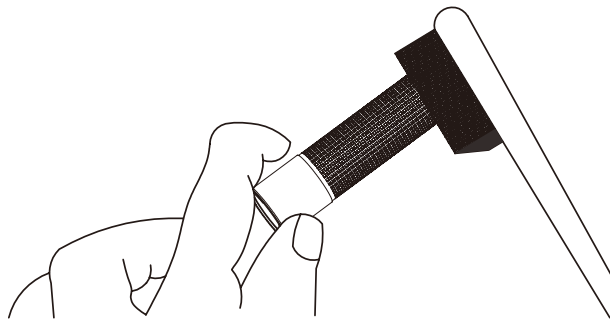

Fig. N



GENERATOR

DXGC4150i, DXGC8250i, DXGC8250Ei

Congratulations!

You have chosen a DeWALT tool. Years of experience, thorough product development and innovation make DeWALT one of the most reliable partners for professional power tool users.

Specification Parameter Table

| | | | DXGC4150i | DXGC8250i | DXGC8250Ei |
|---------------------|----------------------|-----------------|-----------|-----------|------------|
| Generator Parameter | Frequency | Hz | 50 | 50 | 50 |
| | Voltage | V _{AC} | 240V | 240V | 240V |
| | Phase | | Single | Single | Single |
| | Rated Running Power | kW | 3.400 | 6.600 | 6.600 |
| | Rated Starting Power | kW | 4.150 | 8.250 | 8.250 |
| | Power Factor | | 1 | 1 | 1 |
| | Insulation Rate | | F | F | F |
| | Fuel Capacity | L | 3.1 | 6.1 | 6.1 |
| Engine Parameter | Displacement | CC | 196 | 389 | 389 |
| | Start Style | | Recoil | Recoil | Recoil |
| | Oil Capacity | L | 0.6 | 1.1 | 1.1 |

! **WARNING:** This manual contains important instructions for operating the generator. For your safety and that of others, be sure to read this manual thoroughly before operating the generator. Failure to properly follow all instructions and precautions can cause you and others to be seriously hurt or killed. This manual should be considered a permanent part of the generator and should remain with it if resold.

Definitions: Safety Guidelines

The words DANGER, WARNING, CAUTION and NOTICE are used throughout this manual to highlight important information. Be certain that the meanings of these alerts are known to all who work on or near the equipment.

! This safety alert symbol appears with most safety statements. It means attention, become alert, your safety is involved! Please read and abide by the message that follows the safety alert symbol.

The definitions below describe the level of severity for each signal word. Please read the manual and pay attention to these symbols.

! **DANGER:** Indicates an imminently hazardous situation which, if not avoided, **will** result in death or serious injury.

! **WARNING:** Indicates a potentially hazardous situation which, if not avoided, **could** result in death or serious injury.

! **CAUTION:** Indicates a potentially hazardous situation which, if not avoided, **may** result in minor or moderate injury.

! **NOTICE:** Indicates a practice **not related to personal injury** which, if not avoided, **may** result in property damage.

! **NOTE:** Indicates a procedure, practice or condition that should be followed in order for the generator to function in the manner intended.

Safety Symbol Definitions/ Markings on Tool

The following pictograms MAYBE shown on the unit:

| Symbol | Description | Symbol | Description |
|--------|-------------------------------|--------|--|
| | Safety Alert Symbol | | Fire Hazard |
| | Asphyxiation Hazard | | Lifting Hazard |
| | Burn Hazard | | Pinch-Point Hazard |
| | Burst / Pressure Hazard | | Read Manufacturer's Instructions |
| | Don't leave tools in the area | | Wear Personal Protective Equipment (PPE) |
| | Electrical Shock Hazard | | Read Safety Messages Before Proceeding |
| | Explosion Hazard | | |

SAFETY

! **WARNING:** READ THIS MANUAL COMPLETELY BEFORE OPERATING. DO NOT OPERATE THIS GENERATOR UNTIL YOU HAVE READ ALL SAFETY, OPERATION, AND MAINTENANCE INSTRUCTIONS LISTED IN THIS MANUAL. Failure to follow the instructions may result in property damage, INJURY or DEATH.

The warnings and precautions discussed in this manual cannot cover all possible conditions and situations that may occur. It must be understood by the operator that common sense and caution are factors which cannot be built into this product, but must be possessed by the operator.

SAVE ALL WARNINGS AND INSTRUCTIONS FOR FUTURE REFERENCE

! **DANGER:** Using a generator indoors CAN KILL YOU IN MINUTES. Generator exhaust contains carbon monoxide. This is a poison you cannot see or smell. NEVER use inside a home or garage, EVEN IF doors and windows are open. Only use OUTSIDE and far away from windows, doors, and vents.

RISK OF ASPHYXIATION

! **DANGER:** DO NOT OPERATE THIS GENERATOR WITHIN AN ENCLOSED AREA. THE EXHAUST GASES OF THIS GENERATOR EMIT "DEADLY" CARBON MONOXIDE. EXPOSURE TO CARBON MONOXIDE CAN CAUSE CARBON MONOXIDE POISONING, HEADACHES, NAUSEA, SEVERE SICKNESS OR DEATH.

RISK OF ELECTROCUTION OR SHOCK

! **DANGER:** THIS GENERATOR PRODUCES ELECTRICAL CURRENT. THEREFORE, SAFETY GUIDELINES MUST BE FOLLOWED. IMPROPER USE OF THIS GENERATOR CAN RESULT IN ELECTROCUTION, INJURY OR DEATH. DO NOT OPERATE, SERVICE OR REPAIR THIS GENERATOR UNLESS FULLY QUALIFIED TO DO SO.

! **DANGER:** THIS GENERATOR IS DESIGNED TO BE OPERATED IN DRY CONDITIONS AND FOR OUTDOOR AREAS ONLY. NEVER OPERATE THIS GENERATOR INDOORS. NEVER OPERATE THIS GENERATOR IN RAIN, SNOW, SLEET OR GENERALLY WET CONDITIONS. MOISTURE OR ICE CAN CAUSE A SHORT CIRCUIT OR OTHER MALFUNCTION IN THE ELECTRICAL SYSTEM. DAMAGE TO THE GENERATOR, BODILY INJURY, OR DEATH COULD RESULT FROM ELECTROCUTION.

! **DANGER:** IF THIS GENERATOR IS CONNECTED TO A BUILDING, HOME BUSINESS, OR ANY OTHER ELECTRICAL CIRCUIT NORMALLY FED BY UTILITY POWER, STEPS MUST BE TAKEN TO INSURE THE GENERATOR OUTPUT AND THE UTILITY POWER ARE POSITIVELY ISOLATED. THIS IS TYPICALLY ACCOMPLISHED THROUGH THE USE OF A PROPERLY INSTALLED TRANSFER SWITCH. FAILURE TO ISOLATE THE UTILITY AND GENERATOR ELECTRICAL SYSTEMS WILL RESULT IN GENERATOR DAMAGE AND COULD RESULT IN INJURY OR DEATH TO UTILITY WORKERS DUE TO THE BACKFEED OF ELECTRICITY.

! **DANGER:** TO AVOID BACKFEEDING INTO UTILITY SYSTEMS, ISOLATION OF THE RESIDENCE ELECTRICAL SYSTEM IS REQUIRED. BEFORE CONNECTION OF A GENERATOR TO THE RESIDENCE ELECTRICAL SYSTEM TURN OFF THE MAIN SWITCH. BEFORE MAKING PERMANENT CONNECTIONS, A DOUBLE THROW TRANSFER SWITCH MUST BE INSTALLED. TO AVOID ELECTROCUTION OR PROPERTY DAMAGE, ONLY A TRAINED ELECTRICIAN SHOULD CONNECT GENERATOR TO RESIDENCE ELECTRICAL SYSTEM. TEMPORARY CONNECTION IS NOT RECOMMENDED DUE TO BACKFEEDING. ALWAYS FOLLOW LOCAL CODES AND REGULATIONS THAT APPLY TO THE INSTALLATION OF ANY ITEM THAT CONCERNS THIS PRODUCT.

! **DANGER:** Voltage produced by the generator could result in death or serious injury.

- Never operate the generator in rain or a floodplain unless proper precautions are taken to avoid being subject to rain or flood.
- Never use worn or damaged extension cords.
- Always have a licensed electrician connect the generator to any fixed electrical installation.
- Never touch an operating generator if the generator is wet or if you have wet hands.
- Never operate the generator in highly conductive areas such as around metal decking or steel works.

- Always use earthed extension cords. Always use three-wire or double-insulated power tools.
- Never touch live terminals or bare wires while the generator is operating.
- Keep animals and children away from the generator at all times.

 **DANGER:** DO NOT MODIFY OR MISAPPLY YOUR GENERATOR. OPERATION OF THE GENERATOR OTHER THAN INTENDED COULD RESULT IN GENERATOR DAMAGE, BODILY INJURY OR EVEN DEATH FROM ELECTROCUTION

 **DANGER:** NEVER TOUCH A RECEPTACLE OR BARE WIRE. ELECTROCUTION OR SHOCK COULD RESULT.

 **DANGER:** NEVER OPERATE THE GENERATOR IF: POWERED ITEMS OVERHEAT; ELECTRICAL OUTPUT DROPS; THERE ARE SPARKS, FLAMES OR SMOKE COMING FROM THE GENERATOR; OR IF THE RECEPTACLES ARE DAMAGED.

 **DANGER:** NEVER ATTEMPT TO CONNECT MORE THAN ONE GENERATOR TO THE SAME ELECTRICAL DEVICE, EXTENSION CORD OR FIXED ELECTRICAL INSTALLATION.

RISK OF FIRE OR EXPLOSION

 **WARNING:** ALWAYS INSURE THAT AT LEAST 1.8 M OF CLEARANCE ON ALL SIDES OF THE GENERATOR ARE MAINTAINED DURING OPERATION. FAILURE TO MAINTAIN PROPER CLEARANCE COULD DAMAGE YOUR GENERATOR AND POTENTIALLY LEAD TO FIRES.

 **WARNING:** PETROL IS HIGHLY FLAMMABLE AND ITS VAPOURS ARE EXPLOSIVE. FAILURE TO PROPERLY HANDLE PETROL CAN RESULT IN EXPLOSION OR FIRE. DO NOT PERMIT SMOKING WITHIN 15 M OF THIS GENERATOR SET.

 **WARNING:** DO NOT REFUEL WHILE ENGINE IS RUNNING.

WARNING:

- Always refuel the generator outdoors, in a well-ventilated area.
- Never remove the fuel cap while the engine is running.
- Never refuel the generator while the engine is running. Always turn engine off and allow the generator to cool before refuelling.
- Only fill fuel tank with unleaded petrol.
- Keep away from sparks, open flames or other forms of ignition such as matches, cigarettes, CB radios and mobile phones when refuelling.
- Never overfill the fuel tank. Leave room for fuel to expand. Overfilling the fuel tank can result in a sudden overflow of fuel and result in spilled fuel coming in contact with hot surfaces. Spilled fuel can ignite. If fuel is spilled on the generator, wipe it up immediately and dispose of rags properly. Allow area of spilled fuel to dry before operating the generator.
- Wear eye protection while refuelling.
- Never use fuel as a cleaning agent.
- Store any fuel containers in a well-ventilated area, away from any combustibles or source of ignition.
- Check for fuel leaks after refuelling. Never operate the engine if a fuel leak is discovered.
- Equip the operating area with a Class ABE or BE portable fire extinguisher.

 **WARNING:** DO NOT OPERATE IN A HAZARDOUS LOCATION, E.G. WHERE THERE MAY BE A RISK OF EXPLOSION OF FUMES, LEAKING FUEL OR EXPLOSIVE DUSTS.

 **WARNING:** DO NOT STORE THIS GENERATOR IN ANY LOCATION WHERE PETROL FUMES COULD POTENTIALLY COME INTO CONTACT WITH SPARKS, A PILOT LIGHT OR AN OPEN FLAME. IMPROPER STORAGE OF THIS GENERATOR COULD RESULT IN AN EXPLOSION OR FIRE.

 **WARNING:** INSPECT THE SPARK ARRESTOR PERIODICALLY. SPARK ARRESTORS ARE REQUIRED IN SOME AREAS AND MINIMIZE THE RISK OF FIRE FROM SPARKS EMITTED FROM THE EXHAUST:

- This generator may not be equipped with a spark arresting muffler. If the generator will be used around flammable materials, or on land covered with materials such as agricultural crops, forest, brush, grass, or other similar items, then an approved spark arrester must be installed. In some areas, a spark arrester is required by law. Please contact local fire agencies for laws or regulations relating to fire prevention requirements.

 **WARNING:** DO NOT OPERATE THIS GENERATOR IF THE AMBIENT TEMPERATURE EXCEEDS 40 °C.

 **WARNING:** DO NOT EXCEED THE RATED CAPACITY OF THE GENERATOR. THE TOTAL ELECTRICAL LOADS AT EACH OUTLET MUST BE ADDED TO DETERMINE THE TOTAL ELECTRICAL LOAD. THE TOTAL LOAD MUST NOT EXCEED THE RATED CAPACITY OF THE GENERATOR. IF THE DRIVEN APPARATUS DOES NOT LIST WATTAGE, BUT ONLY AMPERAGE, WATTAGE MAY BE DETERMINED BY MULTIPLYING AMPERAGE TIMES VOLTAGE (WATTS = AMPS X VOLTS).

GENERAL SAFETY

Always follow National and Local electrical codes pertaining to generators. All local and national codes supersede rules or information provided in this manual.

 **WARNING:** REFER TO LOCAL AND NATIONAL ELECTRICAL CODES TO DETERMINE GROUNDING REQUIREMENTS AS THIS CAN VARY PER APPLICATION. THE GENERATOR IS GROUNDED INTERNALLY NEUTRAL TO FRAME. WHERE APPLICATIONS REQUIRE EXTERNAL GROUNDING, A CONNECTION MUST BE MADE FROM THE GENERATOR TO A SOLID EARTH GROUND. A CONTINUOUS LENGTH OF SPLICE FREE COPPER CABLE, NO SMALLER THAN 6 AWG, SHALL BE USED FOR THE CONDUCTOR.

 **WARNING:** NEVER USE THE GENERATOR TO POWER MEDICAL SUPPORT EQUIPMENT.

• When moving or transporting this generator, take proper precautions to avoid fuel spillage. Further, always use common sense when lifting this generator. An adequate number of people and proper lifting methods must be used.

• Do not cover the generator while it is running or immediately after shut down. Always allow time to cool down before covering.

• Do not operate this generator unless it is in good mechanical and electrical condition.

• Always keep hands, body parts, hair and clothing well away from the rotating parts of the generator.

• Do not start this generator with connected devices turned "ON". Always make sure that connected devices are disconnected from the generator or turned "OFF" before starting the generator.

• Generators operating on job or construction sites may be required to have RCD (Residual Current Device) receptacles.

• Use only grounded extension cords in good condition and make sure that the wire size within the extension cords is of sufficient size to safely carry the surge output of the out let the cord is plugged into.

• Never handle extension cords or electrical circuits if standing in water or if standing in a damp area.

• You must take reasonable care for the health and safety both of yourself and any others who may be affected by your actions. You must understand and follow all of the safety rules and working instructions described herein. You must also use your own good judgement and common sense.

 **WARNING:** Always remove any tools or other service equipment used during maintenance before operating the generator.

NOTICE:

- Never modify the generator.
- Never operate the generator if it vibrates at high levels, if the engine speed changes greatly or if the engine misfires often.
- Always disconnect electric tools or appliances from the generator before starting.

RISK OF BODILY INJURY

 **WARNING:** KEEP HANDS, BODY PARTS, HAIR AND CLOTHING AWAY FROM THE HOT PARTS OF THE GENERATOR DURING AND AFTER OPERATION. THE EXHAUST SYSTEM, AND THE GENERATOR IN GENERAL, CAN REMAIN VERY HOT EVEN AFTER BEING SHUT DOWN

 **WARNING:** DO NOT TAMPER WITH THE ENGINE GOVERNED SPEED. THE GENERATOR OPERATES AT A NOMINAL SPEED OF 3600 RPM. INCREASES IN SPEED OVER THE 3600 RPM NOMINAL WILL INCREASE THE CHANCE OF PERSONAL INJURY DUE TO ROTATIONAL STRESSES ON THE ROTATING MEMBERS. OPERATION OF THE GENERATOR AT SPEEDS BELOW THE NOMINAL 3600 RPM COULD CAUSE DAMAGE TO THE GENERATOR OR DRIVEN APPARATUS DUE TO LOW VOLTAGE OUTPUT

BATTERY SAFETY

 **WARNING:** STORAGE BATTERIES PRODUCE AND RELEASE EXPLOSIVE HYDROGEN GAS WHEN CHARGING. THE SLIGHTEST SPARK, FLAME OR BURNING ASH CAN IGNITE THESE GASES CAUSING A SERIOUS EXPLOSION THAT COULD RESULT IN BLINDNESS OR OTHER SERIOUS INJURIES. WEAR EYE PROTECTION, RUBBER APRON AND RUBBER GLOVES WHEN WORKING AROUND A BATTERY OR PERFORMING BATTERY SERVICE. BATTERY FLUID IS AN EXTREMELY CAUSTIC SULPHURIC ACID, WHICH CAN CAUSE SEVERE BURNS. ALWAYS DISCONNECT THE NEGATIVE (-) BATTERY CABLE FROM THE BATTERY BEFORE PERFORMING BATTERY SERVICE OR BEFORE PERFORMING ANY ELECTRICAL SERVICE ON THE GENERATOR OR ENGINE.

ENVIRONMENTAL PROTECTION

 **CAUTION:** INSPECT THE EXHAUST SYSTEM REGULARLY TO ENSURE IT IS FUNCTIONING PROPERLY. LEAKY EXHAUST SYSTEMS WILL INCREASE NOISE LEVELS.

 **CAUTION:** DIRECT THE "LOUD" SIDES OF THE GENERATOR INTO OPEN SPACES AVOIDING REVERBERATION FROM WALLS OR BUILDINGS THUS AMPLIFYING THE SOUND.

NOTICE: NEVER DRAIN OR DISPOSE OF ENGINE OIL INTO THE GROUND OR DOMESTIC WASTE WATER SYSTEMS.

Raising or Suspending Generator

 **WARNING:** Always use cables, chains or straps rated at 900 kg. working load or more to raise or suspend generator.

 **WARNING:** Never operate generator while suspended. This could cause property damage, serious injury or death.

 **WARNING:** Make sure all fasteners in frame and lifting hook are tight.

NOTICE: Make sure the generator is in a level position before raising or suspending to prevent damage

Package Contents

Set the carton on a rigid, flat surface.

Remove everything from carton except generator.

Open carton completely by cutting each corner from top to bottom.

- Check for damage to the tool, parts or accessories which may have occurred during transport.
- Take the time to thoroughly read and understand this manual prior to operation.

Data Decal (Fig. A)

The data decal 7 contains model number, serial number and actual wattage requirements.

Example:

2020 XX XX
Year of Manufacture

Description (Fig. A, B)

WARNING: Never modify the generator or any part of it. Damage or personal injury could result.

Become familiar with locations of all components.

Read the Owner's Manual and Safety Rules before operating this generator. Save this manual for future reference.

- | | |
|-----------------|------------------------------|
| 1 Fuel tank | 7 Back side of control panel |
| 2 Fuel tank cap | 8 Air filter |
| 3 Muffler guard | 9 Recoil starter |
| 4 Control panel | 10 Battery tray (DXGC8250Ei) |
| 5 Frame | |
| 6 Rear cover | |

11 Engine Control Switch:

MANUAL START(DXGC4150i,DXGC8250i):

ON-Place the START switch in the ON position before start.

OFF-To stop the engine,move the switch to the OFF position.

- 12 **E-START(DXGC8250Ei):**-Turn key to START and held in the START position,the electric starter motor engages and starts the engine.Once the engine starts,release the switch.The switch will then automatically return to the ON position.
ON-Once started,the switch will remain in the ON position.
OFF-To stop the engine,move the switch to the OFF position.

- 13 **Residual Current Device (RCD) Safety Switch (if equipped):**Designed to protect the operator against electric shock by disconnecting all AC outlets in the event of a detected current leakage. The switch will automatically move to the OFF position in the event of a fault and must be manually reset when safe to do so after rectifying the electrical fault.

- 14 **240-Volt AC, 15-Amp Outlet(s):**Each outlet is capable of delivering the generator's full output or 15 Amps (2400 Watts), whichever is the lesser.

- 15 **240-Volt AC, 10-Amp Outlet(s):** Each outlet is capable of delivering the generator's full output or 15 Amps (2400 Watts), whichever is the lesser.

Intended Use

This generator is intended for residential consumer use only. DO not modify the engine and do not use the engine for a purpose for which it is not intended.

DO NOT let children come into contact with the tool. Supervision is required when inexperienced operators use this tool.

- **Young children and the infirm.** This appliance is not intended for use by young children or infirm persons without supervision.
- This product is not intended for use by persons (including children) suffering from diminished physical, sensory or mental abilities; lack of experience, knowledge or skills unless they are supervised by a person responsible for their safety. Children should never be left alone with this product.

ASSEMBLY AND ADJUSTMENTS

Unpacking

CAUTION: Always have assistance when lifting the generator. The generator is heavy; lifting it could cause bodily harm.

CAUTION: Avoid cutting on or near staples to prevent personal injury.

- Place the shipping carton on a solid, flat surface.
- Carefully cut each corner of the carton box from top to bottom. Fold each side flat on the ground.
- Remove everything from the carton except the generator.

Battery Cable Connection (Electric Start Only)

The unit has been deliberately shipped with the battery cables disconnected.

To connect the battery, you will need to connect the battery cables. 10 :

WARNING: To avoid electric shock:

- ALWAYS connect the positive (+) battery cable (red boot) first when connecting battery cables.
- ALWAYS disconnect the negative (-) battery cable (black boot) first when disconnecting battery cables.
- NEVER connect the negative (-) battery cable (black boot) to the positive (+) terminal on the battery.
- NEVER connect the positive (+) battery cable (red boot) to the negative (-) terminal on the battery.
- NEVER touch both battery terminals simultaneously.
- NEVER place a tool or other metal object across both battery terminals.
- NEVER place a tool or other metal object between either of the battery terminals and any part of the generator.
- ALWAYS use insulated or non-conducting tools when installing the battery.

1. Cut off cable ties securing battery cables and remove red covers from battery terminals.
2. First, connect the red cable to the positive (+) battery terminal with the bolt and nut.
3. Make sure connections are secure and slide rubber boot over the positive (+) battery terminal and connection hardware.
4. Connect the black cable to the negative (-) battery terminal with the bolt and nut supplied and slide rubber boot over the negative (-) battery terminal and connection hardware.
5. Make sure all connections are secure.

NOTE: If the battery is unable to start the engine, charge it with the 12V charger (see the **Charging a Battery** section for details).

Grounding Generator if Used as Portable

The generator's equipotential bonding system including the frame ground terminal should not be connected to the general mass of earth through a separate earth electrode. For more information, refer to AS/NZS 3010:2005 Electrical Installations – Generating Sets or consult a licensed electrician.

DANGER: Electrical shock. Failure to properly ground the generator can result in electric shock.

Special Requirements

- There may be Australian Workplace Health and Safety laws that apply to the intended use of the generator*.
- There may be rules under New Zealand Health and Safety law that apply to the intended use of the generator.

Consult a qualified electrician, electrical inspector, or the local agency having jurisdiction:

- In some areas, generators are required to be registered with local utility companies.
- If the generator is used at a construction site, there may be additional regulations which must be observed

Connecting the Generator to a Building's Electrical System

When connecting directly to a building's electrical system, it is recommended that a manual transfer switch is used. Connections for a portable generator to a building's electrical system must be made by a qualified electrician and in strict compliance with all national and local electrical codes and laws.

Know Generator Limits

Overloading a generator in excess of its rated wattage capacity can result in damage to the generator and to connected electrical devices. Observe the following rules to avoid overloading:

- Add up the total wattage of all electrical devices to be connected at one time. The total should NOT be greater than the wattage capacity of the generator.
- The rated wattage of lights can be taken from light bulbs. The rated wattage of tools, appliances and motors can usually be found on a data label or decal affixed to the device.
- If the appliance, tool or motor does not give wattage, multiply volts times ampere rating to determine watts (volts x amps = watts).
- Some electric motors, such as induction types, require about three times more watts of power for starting than for running. This power surge lasts only a few seconds. To allow for high starting wattage when selecting electrical devices to connect to the generator, proceed as follows:

1. Figure the watts needed to start the largest motor.
2. Add to that figure the running watts of all other connected loads.
3. See **Wattage Reference Guide** for help in determining how many items the generator can operate at one time.

NOTICE: All figures are approximate. See data label 7 on appliance for actual wattage requirements.

Wattage Reference Guide

| Device | Running Watts |
|--------------------------------------|---------------|
| *Air Conditioner (12,000 Btu) | 1700 |
| *Air Conditioner (24,000 Btu) | 3800 |
| *Air Conditioner (40,000 Btu) | 6000 |
| Battery Charger (20 Amp). | 500 |
| Belt Sander (3") | 1000 |
| Chain Saw | 1200 |
| Circular Saw (6-1/2") | 800 to 1000 |
| *Clothes Dryer (Electric) | 5750 |
| *Clothes Dryer (Gas) | 700 |
| *Clothes Washer | 1150 |
| Coffee Maker | 1750 |
| *Compressor (1 HP) | 2000 |
| *Compressor (3/4 HP) | 1800 |
| *Compressor (1/2 HP) | 1400 |
| Curling Iron. | 700 |
| *Dehumidifier | 650 |
| Disc Sander (9") | 1200 |
| Edge Trimmer | 500 |
| Electric Blanket | 400 |
| Electric Nail Gun | 1200 |
| Electric Range (per element) | 1500 |
| Electric Skillet | 1250 |
| *Freezer | 700 |
| *Furnace Fan (3/5 HP) | 875 |
| *Garage Door Opener | 500 to 750 |
| Hair Dryer | 1200 |
| Hand Drill | 250 to 1100 |
| Hedge Trimmer | 450 |
| Impact Wrench | 500 |
| Iron. | 1200 |
| *Jet Pump | 800 |
| Lawn Mower | 1200 |
| Light Bulb | 100 |
| Microwave Oven | 700 to 1000 |
| *Milk Cooler | 1100 |
| Oil Burner on Furnace | 300 |
| Oil Fired Space Heater (140,000 Btu) | 400 |
| Oil Fired Space Heater (85,000 Btu) | 225 |
| Oil Fired Space Heater (30,000 Btu) | 150 |
| *Paint Sprayer, Airless (1/3 HP) | 600 |
| Paint Sprayer, Airless (handheld). | 150 |
| Radio | 50 to 200 |
| *Refrigerator | 700 |
| Slow Cooker | 200 |
| *Submersible Pump (1-1/2 HP) | 2800 |
| *Submersible Pump (1 HP) | 2000 |
| *Submersible Pump (1/2 HP) | 1500 |
| *Sump Pump | 800 to 1050 |
| *Table Saw (10") | 1750 to 2000 |
| Television | 200 to 500 |
| Toaster | 1000 to 1650 |
| Weed Trimmer | 500 |

*Allow 3 times the listed watts for starting these devices.

OPERATION

Instructions for Use



WARNING: Always observe the safety instructions and applicable regulations.



DANGER: Never operate in an enclosed area or indoors! NEVER use in the home, in a vehicle, or in partly enclosed areas such as garages, EVEN IF doors and windows are open! ONLY use out doors and far from open windows, doors, vents, and in an area that will not accumulate deadly exhaust.



DANGER: The engine exhaust fumes contain carbon monoxide, which cannot be seen or smelled. The gas is poisonous, and if breathed in sufficient concentrations, can cause unconsciousness or even death.



DANGER: Adequate, unobstructed flow of cooling and ventilating air is critical to generator operation. Do not alter the installation or permit even partial blockage of ventilation provisions, as this can seriously affect safe operation of the generator. The generator MUST be operated outdoors.



DANGER: The exhaust system must be properly maintained. Do nothing that might render the exhaust system unsafe or in non-compliance with any local codes and/or standards.



DANGER: Always use a battery operated carbon monoxide alarm indoors. Be sure it is properly installed according to the manufacturer's instructions.

Operating Checklist

Operating Location

- Only use OUTSIDE and place the generator in a well-ventilated area and carefully consider wind and air currents. Never operate your generator outdoors during rain, snow or any combination of weather conditions that could lead to moisture collecting on, in or around the generator.
- Place the generating set on a level surface before any operation. Always operate the generator on a dry surface free of any moisture.
- Allow at least 1.8 m away from any building, other equipment or combustible material. If the generator is located close to a building, it is not located near any windows, doors and/or vents.

High Altitude



CAUTION: Operation of the engine with a high-altitude carburettor kit at an altitude below 1524 meters may cause the engine to overheat and result in serious engine damage.

This engine will have proper engine performance and emission control when it is operated at or below an altitude of 1524 meters. This engine requires a high-altitude carburettor kit to ensure proper engine performance and emission control when it is operated at altitudes above 1524 meters. Operating the engine with the wrong engine configuration above 1524 meters may increase its emissions and decrease fuel efficiency and performance. To obtain a high-altitude carburettor kit, contact an authorised DeWALT repair agent.

Operating Condition

- Check for loose or damaged parts, signs of oil or fuel leaks, and any other condition that may affect proper operation.
- Repair or replace all damaged or defective parts immediately.
- **WARNING:** Failing to correct problem(s) before operation could result in property damage, serious injury or DEATH.
- Check the air filter. A dirty air filter will restrict air flow to the carburettor, reducing engine performance.
- Remove any excessive dirt or debris, especially around the muffler and recoil starter.
- DO NOT move or tip the generator during operation.
- Use generator only for intended uses. If you have questions about intended use contact an authorised DeWALT repair agent.

Before Starting Generator



Be sure the generator is properly installed before operating to reduce the possibility of electric shock. Generators equipped with a RCD Safety Switch offer much better protection against electric shock as mandated by Australian Workplace Health and Safety Regulations. Any connection to an electrical installation such as in a building, for example, must be carried out by a licensed electrician.

Before starting the generator, always check the engine oil and fuel levels.

After starting the generator, it is not safe to add fuel to the fuel tank or engine oil to the engine while the engine is running or immediately after stopping while the engine and muffler are still hot.

Add Engine Oil (Fig. F)



DANGER: Internal pressure can build up in the engine crankcase while the engine is running. Removing the oil fill plug/ dipstick while the engine is hot can cause extremely hot oil to spray out of the crankcase and can severely burn skin. Allow engine oil to cool for several minutes before removing the oil fill plug/dipstick.

NOTICE: The engine IS NOT filled with oil at the factory. Any attempt to crank or start the engine before it has been properly filled with the recommended type and amount of oil may result in engine damage and may affect your ability to make a claim under any express warranty, [including the Limited Warranty and Emission Control System Warranty], or any warranty implied by operation of law.

NOTICE: Oil is a major factor affecting performance and service life. Use 4-stroke automotive detergent oil recommended in the **Maintenance** section of this manual.

NOTICE: Operate generator only on level surfaces. The low oil sensor (if equipped) will automatically stop the engine when the oil level falls below the safe limit. To avoid the inconvenience of an unexpected shut-down, fill to the upper limit and check the oil level regularly.

Engine damage could result from insufficient lubrication. Refer to **Add Oil** instructions under **Maintenance** section for information.

NOTE: See **Specification Parameter Table** for oil capacity.

To Check Oil Level

1. Place generator on a level surface.
2. Remove dipstick and wipe it clean.
3. Reinstall dipstick into tube: rest on oil fill neck. DO NOT thread dipstick into tube.
4. Remove the dipstick again and check the oil level should be at top of indicator on dipstick as shown in Figure F.
5. Add recommended oil to the upper limit of the dipstick, if needed. Use premium quality 4-stroke engine oil with an API Service Classification of at least SG. A SAE multigrade viscosity of 5W-30 or 10W-30 is recommended for general, all-temperature use. Other viscosities shown in the chart (Figure C) may be used when the average temperature in your area is within the indicated range. See **Specification Parameter Table** for oil capacity (rated). NEVER use 2-stroke engine oil either directly in the engine or mixed with the fuel.

Fuel (Fig. D)

DANGER: Never fill fuel tank indoors. Never fill fuel tank when engine is running hot. Do not spill petrol on a hot engine. Allow engine to cool before filling fuel tank.

DANGER: Do not overfill fuel tank. Always leave room for fuel expansion. If fuel tank is overfilled, fuel can overflow onto a hot engine causing FIRE or EXPLOSION. Wipe up any spilled fuel immediately.

DANGER: Petrol is highly FLAMMABLE and its vapours are EXPLOSIVE. Never permit smoking, open flames, sparks or heat in the vicinity while handling petrol.

DANGER: Avoid prolonged skin contact with fuel. Avoid prolonged inhalation of fuel vapours.

CAUTION: Pressure can build in the fuel tank. Allow the engine to cool for at least two minutes before removing fuel cap. Loosen the fuel cap slowly to relieve any pressure in the tanks.

- With the engine stopped, check the fuel level gauge. Refill the fuel tank if necessary.
- Use clean, fresh, unleaded petrol with a minimum octane rating of 87. DO NOT mix oil with petrol or use petrol older than 30 days. DO NOT use petrol that contains more than the 10% ethyl alcohol. E15, E20 and E85 are NOT approved fuels and should NOT be used.
- DO NOT modify engine to run on alternate fuels. Stabilize fuel prior to storage.

1. Verify unit is OFF and cooled for a minimum of two minutes prior to fuelling.
2. Place unit on level ground in a well-ventilated area.
3. Clean area around fuel cap and remove cap slowly.
4. Slowly add recommended fuel. Be sure not to fill the fuel tank about the upper limit mark. Always allow room for fuel expansion. See **Specification Parameter Table** for fuel capacity (rated).
5. Install fuel cap

NOTICE: Allow spilled fuel to evaporate before starting unit.

IMPORTANT: It is important to prevent gum deposits from forming in fuel system parts such as the carburettor, fuel hose or tank during storage. Alcohol blended fuels (called gasohol, ethanol or methanol) can attract moisture, which leads to separation and formation of acids during storage. Acidic gas can damage the fuel system of an engine while in storage. To avoid engine problems, the fuel system should be emptied before storage of 30 days or longer. See the **Storage** section. Never use engine or carburettor cleaner products in the fuel tank as permanent damage may occur.

Electrical Devices (Fig. E)

- Disconnect all electrical devices from the generator and switch off RCD Safety Switch before start the engine.
- The generator may be hard to start with electrical devices connected.

Starting the Engine

CAUTION: Equipment and property damage. Disconnect electrical loads prior to starting or stopping unit. Failure to do so could result in equipment and property damage.

1. Perform **Operating Checklist**.
2. Turn fuel valve to the "ON" position (Fig. F).
3. Turn OFF the RCD 13.
4. Move the choke lever to "CLOSED" position (Fig. F).

CAUTION: Choke position for starting may vary depending upon temperature and other factors. If re-starting a warm engine, the choke should be left in the HALF or CLOSED position.

5. Start:

- a. **Electric start (Fig. H) (DXGC8250Ei):** Turn key to START and held in the START position, the electric starter motor engages and starts the engine. Once the engine starts, release the switch. The switch will then automatically return to the ON position.

NOTICE: Failure to release the engine control switch once the engine starts can result in damage to the generator. Never push the engine control switch to the START position while the engine is running; this can damage the generator.

NOTE: If the engine fails to start after 5 seconds, release the engine control switch. Let the generator rest for 15 seconds and then try to start again. If the cranking speed

drops after each unsuccessful attempt, the battery may not be adequately charged; manually start the generator as instructed in **Manually Start**.

NOTE: The electric start generator is equipped with a battery charging feature. Once the engine is running, a small charge is supplied to the battery via the battery cables and will slowly recharge the battery.

- b. **Manual start (Fig. G):** Push the engine control switch into the ON position.

WARNING: KICKBACK. Rapid retraction of the starter cord will pull your hand and arm toward the engine faster than you can let go. Accidental starts can result in entanglement, traumatic amputation or lacerations. Broken bones, fractures, bruises or sprains could result.

6. If the starter fails to start the engine, immediately turn off the starter. Don't attempt to restart the engine before the failure cause is identified. Don't restart the engine by replacement of other storage battery without authorization.

WARNING:

- If the engine fails to start after attempt for 3 times or flames out after starting, inspect and ensure that the generator is placed in horizontal surface and enough engine oil is included.
- During starting, don't keep the starting switch to "START" position for more than 5 seconds, otherwise it is possible to damage the starter motor. If the unit fails to start within first time, restart after about 10 seconds. After the unit is used for a period, if the starting speed of the motor falls, please replace the storage battery.
- During the operation of the unit, the storage battery supplies power for the solenoid valve of the carburettor. For this, when the unit is turned off, make sure that the starting switch is in "OFF" position and otherwise the storage battery voltage is reduced due to the operating solenoid valve of the carburettor, impacting on starting for next time.
- If the engine is equipped with an engine oil alarm, it is possible to prevent engine start when the engine oil in the crankcase is lower than minimum level.
- During running-in, routinely inspect the engine oil. See **Maintenance** section for recommended maintenance period.

7. After the engine is running, move the choke valve to "OPEN" position (Fig. G,H).

WARNING: Connect the output terminal of the generating set with the electrical equipment. Don't start or stop the engine when the electrical equipment is in "ON" status.

Connect to Electrical Devices (Fig. I)

DANGER: Electric Shock

- To reduce the risk of electrical shock, DO NOT use electrical cords that are worn, frayed, bare or otherwise damaged.
- DO NOT touch bare wires of receptacles.
- DO NOT handle generating set or electrical cords while standing in water, while barefoot, while hand or feet are wet.

- Inspect power cord for damage before using. There is a hazard of electric shock from crushing, cutting or heat damage.
- Allow the engine to stabilize and warm up for a few minutes after starting.
- Make sure the electrical devices are in the "OFF" position and the load current is not higher than the maximum capacity current of single socket.

CAUTION: If the current of single load is higher than the maximum capacity current of single socket, please disconnect the load.

CAUTION: If connected devices overheat, turn them off and disconnect them from generator.

Bearing Capacity (Fig. J)

WARNING:

- DO NOT overload the generating set.
- Exceeding the capacity of generator can damage the generator and/or electrical devices connected to it.

You must make sure your generator can supply enough rated (running) and surge (starting) watts for the electrical devices you will power at the same time. Follow these simple steps to calculate the running and starting watts necessary for your purposes.

1. Select the electrical devices you will power at the same time.
2. The amount of power you need to run all the devices is the total rated (running) watts of these items.
3. Identify how may surge (starting) watts you will need. Surge wattage is the short burst of power needed to start electric motor-driven tools or appliances such as a circular saw or refrigerator. Because not all motors start at the same time, total surge watts can be estimated by adding only the electrical device(s) with the highest additional surge watts to the total rated watts from step 2.

WARNING: You must isolate the generator from electric utility by opening the electrical system's main circuit breaker or main switch if the generator is used for backup power. Failure to isolate the generator from the power utility may result in injury or death to electric utility workers and damage to the generator due to back-feed of electrical energy.

Extension Cords

NOTICE: DO NOT use standard 10 A extension cords fitted with standard domestic 10 A plugs and sockets. These do not have sufficient current carrying capacity, which will result in excessive voltage drop. 10 A extension cords may overheat and possibly catch fire if overloaded when connected to the generator's outlets.

NOTICE: DO NOT use extension cords with only 2-pin (active and neutral) plugs and sockets. These extension cords lack the earth connection that is provided by a 3-pin plug and socket joined with a 3-core cable; the vertical pin is the earth connection.

Wherever possible, it is recommended to connect AC devices directly to the generator's AC outlet(s). This ensures that the device is supplied with the best quality electricity. In those instances where it's not practicable or safe to directly plug an electrical device into the generator, the use of an electrical extension cord is necessary.

1. Use only the shortest possible extension cord for the task. Voltage drop increases proportionately with the length of an extension cord and may result in damage to the powered device.
2. Use only a single extension cord and not multiple cords joined together. This will minimise voltage drop and prevent any hazard or inconvenience arising from the joint(s) becoming disconnected.
3. Use only extra heavy duty 15 A extension cords made from 3-core cable of at least 1.5 mm² conductor size and fitted with 15 A plugs and sockets. A 15 A plug cannot be inserted into a standard domestic 10 A socket.
4. Extension cords with conductor size of 1.5 mm² or 2.5 mm² should not exceed 25 m or 40 m in length, respectively, in accordance with AS/NZS 3199:2007.
5. The extra heavy duty AC 15 A outlets (if equipped) can be used with extension cords fitted with Clipsal 56-Series (or equivalent) plugs to achieve a weatherproof IP66 and thread-secured electrical connection.
6. DO NOT use extension cords with any visible signs of damage to the plug, socket or cable.
7. DO NOT use extension cords that are rolled up or knotted as they may overheat.

Stopping the Engine

CAUTION: Equipment and property damage. Disconnect electrical loads prior to starting or stopping unit. Failure to do so could result in equipment and property damage.

WARNING: NEVER stop the engine with electrical devices connected".

1. Unplug any electrical cords or devices (Fig. E).
2. Allow the generator to run at no load for a few minutes to stabilize internal temperatures of the engine and generator.
3. **Electric Start (Fig. J):** Push the engine control switch to the OFF position.
4. **Recoil Start (Fig. K):** Push the engine control switch to the OFF position.
5. Turn the fuel valve to "OFF" position.

During an Emergency

If there is an emergency and the generator must be stopped quickly, push the engine control switch to the OFF position immediately.

Charging the Battery (electric start units only)

WARNING: Storage batteries give off explosive hydrogen gas while recharging. An explosive mixture will remain around then battery for a long time after it has been charged. The slightest spark can ignite the hydrogen and cause an explosion, resulting in blindness or other serious injury.

WARNING: DO NOT allow smoking, open flame, sparks or any other source of heat around a battery. Wear protective goggles, rubber apron and rubber gloves when working around a battery. Battery electrolyte fluid is an extremely caustic sulphuric acid solution that can cause severe burns. If spill occurs flush area with clear water immediately.

NOTE: The electric start generator is equipped with a battery charging feature. Once the engine is running, a small charge is supplied to the battery via the battery cables and will slowly recharge the battery.

Charge the battery using a 12V battery Charger and keep the full charge of the battery for use at any time. Charge the battery in dry environment.

To Recharge Batteries, Proceed as Follows:

1. Check fluid level in all battery cells. If necessary, add ONLY distilled water to cover separators in battery cells.
2. DO NOT use tap water.
3. If the battery is equipped with vent caps, make sure they are installed and are tight.
4. If necessary, clean battery terminals.
5. Connect battery charge cable clamp, on a 12V battery charger, with red handle to the positive (+) battery terminal.
6. Connect battery charge cable clamp on a 12V battery charger, with black handle to the negative (-) battery terminal.
7. Start engine. Let the engine run while battery recharges. When battery has charged, shut down engine

NOTICE: Use an automotive hydrometer to test battery state of recharge and condition. Follow the hydrometer manufacturer's instructions carefully. Generally, a battery is considered to be at 100% state of charge when specific gravity of its fluid (as measured by hydrometer) is 1.260 or higher.

MAINTENANCE

Regular maintenance will improve performance and extend generator life. See a qualified dealer for service. Generator warranty does not cover items subjected to operator abuse or negligence. To receive full warranty value, operator must maintain generator as instructed in this manual, including proper storage as detailed in **Storage and Transportation**.

WARNING: Improper maintenance or failure to correct a problem before operation can cause a malfunction and result in property damage, serious injury or DEATH. Improper maintenance may affect your ability to make a claim under any express warranty, [including the Limited Warranty and Emission Control System Warranty], or any warranty implied by operation of law.

WARNING: Accidental starts can cause severe injury or death. Avoid accidentally starting the generator during maintenance by removing the spark plug boot from the spark

plug. For electric start generators, also disconnect the battery cables from the battery (disconnect the black negative (-) cable first) and place the wires away from the terminals to avoid arcing.



DANGER: The filter element may contain polyaromatic hydrocarbons (PAHs) PAHs are harmful to your health. Please wear gloves for protection during air filter maintenance.



DANGER: Always perform maintenance in a well-ventilated area. Fuel and fuel vapours are extremely flammable and can ignite under certain conditions.



DANGER: Internal pressure can build up in the engine crankcase while the engine is running. Removing the oil fill plug/ dipstick while the engine is hot can cause extremely hot oil to spray out of the crankcase and can severely burn skin. Allow engine oil to cool for several minutes before removing the oil fill plug/dipstick.



WARNING: Allow hot components to cool to the touch prior to performing any maintenance procedure.



WARNING: Avoid skin contact with engine oil or fuel. Prolonged skin contact with engine oil or fuel can be harmful. Frequent and prolonged contact with engine oil may cause skin cancer. Take protective measures and wear protective clothing and equipment. Wash all exposed skin with soap and water.



WARNING: Failure to perform periodic maintenance or not following maintenance procedures can cause the generator to malfunction and could result in death or serious injury.

Maintenance Schedule

Follow the service intervals indicated in the **Maintenance Chart**. Your generating set may need to be serviced more frequently when operation in adverse conditions, such as excessive dust or airborne debris, high vibrations intense heat or sunlight.

Maintenance Chart

| | | Each time before use | The first month or 10 hours (2) | Every three months or 50 hours (2) | Every six months or 100 hours (2) | Every year or 300 hours (2) |
|---------------------------------|---------------------------|----------------------|---------------------------------|------------------------------------|-----------------------------------|-----------------------------|
| Engine oil | Inspection | √ | | | | |
| | Replacement | | √ | √ | | |
| Air cleaner | Inspection | √ | | | | |
| | Cleaning | | | √ (3) | | |
| Spark plug | Inspection and adjustment | | | | √ | |
| | Replacement | | | | | √ |
| Spark extinguisher (1) | Cleaning | | | | √ | |
| Idle speed | Inspection and adjustment | | | | | √ (4) |
| Valve clearance | Inspection and adjustment | | | | | √ (5) |
| Carbon canister (1) | Inspection | | | Every two years (4) | | |
| Low permeability oil tube (1) | Inspection | | | Every two years (4) | | |
| Oil tube | Inspection | | | Every two years (4) | | |
| RCD Safety Switch (if equipped) | Test | √ | | | | |

Note 1: Applicable types.

Note 2: Before each season and after then (whichever comes first).

Note 3: Service more frequently under severe, dusty, dirty conditions.

Note 4: To be performed by knowledgeable, experienced owners or the authorised dealer.

Note 5: To be performed by knowledgeable, experienced owners or the authorised dealer, but not necessary to keep the emission control warranty valid.

Generator Maintenance



WARNING:

- DO NOT modify the generator in any way.
- DO NOT tamper with governed speed. Generating set supplies correct rated frequency and voltage when running at factory. Tampering with the factory set governor may affect your ability to make a claim under any express warranty, [including the Limited Warranty and Emission Control System Warranty], or any warranty implied by operation of law.

Cleaning

- Make certain that the generator is kept clean and stored properly. Use a damp cloth to clean exterior surfaces of the generator.
- Use an air compressor (25 PSI) to clear dirt and debris from the generator.
- Inspect all air vents and cooling slots to ensure that they are clean and unobstructed.



WARNING: DO NOT use water to clean the generator. Water can enter the generator through the cooling slots and damage the generator windings.



WARNING: Use a cloth dampened with a mixture of household detergent and warm water. Wipe the exterior surfaces of the generator clean and then repeat with a cloth dampened with clean water. Finish by wiping off all moisture with a dry cloth. Do not use abrasive or solvent cleaners. A soft, non-metallic bristle brush and/or a vacuum cleaner may be used to loosen and remove any built-up dirt, mud or other debris. Low pressure compressed air may also be used to blow off any dirt or dust.

Engine Maintenance

Engine Oil (Fig. C)

NOTICE: The engine is not filled with oil at the factory. Any operation before it is properly filled with the recommended type and amount of oil may result in engine damage and may affect your ability to make a claim under any express warranty, [including the Limited Warranty and Emission Control System Warranty], or any warranty implied by operation of law.

Use premium quality 4-stroke engine oil with an API Service Classification of at least SG. A SAE multigrade viscosity of 5W-30 or 10W-30 is recommended for general, all-temperature use. Other viscosities shown in the chart (Figure C) may be used when the average temperature in your area is within the indicated range. See **Specification Parameter Table** for oil capacity (rated).

NEVER use 2-stroke engine oil either directly in the engine or mixed with the fuel.

Mineral based, semi-synthetic or fully synthetic oils may be used, but different types of oils should not be mixed together. The engine oil supplied originally with the generator is a mineral type with SAE 10W-30 viscosity.

NOTICE:

- Always maintain proper engine oil level. Failure to maintain proper engine oil level can result in severe damage to the engine and/or shorten the life of the engine.
- Always use the specified engine oil. Failure to use the specified engine oil can cause accelerated wear and/or shorten the life of the engine.

Add Oil

1. Place the generator on a level surface.
2. Stop engine if running.
3. Let engine sit and cool for several minutes (allow crankcase pressure to equalize).
4. Clean around the oil fill plug/ dipstick.
5. Remove the dipstick and wipe it clean.
6. Slowly recommended oil to the upper limit (See Figure C). Stop frequently to check the level to avoid overfilling.
7. Replace the dipstick and fully tighten.
8. Properly dispose of any used oil at an approved waste management facility.

Change Oil

 **CAUTION:** Change oil when the engine is warm from operation.

1. Place generator on a level surface.
2. Stop engine if running.
3. Let engine sit and cool for several minutes (allow crankcase pressure to equalize).
4. Clean around the oil fill plug/ dipstick.
5. Remove oil dipstick.
6. Remove the oil drain plug and allow the oil to drain completely.
7. Reinstall and fully tighten the drain plug.
8. Slowly recommended oil to the upper limit (See Figure C). Stop frequently to check the level to avoid overfilling. Reinstall and fully tighten the dipstick.
9. Dispose of used oil at an approved waste management facility.

NOTICE: Never dispose of used engine oil by dumping the oil into a sewer, on the ground, or into groundwater or waterways. Always be environmentally responsible. Follow the guidelines of the governmental agencies for proper disposal of hazardous materials. Consult local authorities or reclamation facility.

Air Filter (Fig. L)

Never use fuel or other flammable solvents to clean the air filter. Use only household detergent and warm water or alternatively a non-flammable solvent.

 **NOTICE:** DO NOT run the generator without the air filter. Serious damage to the engine can result without the air filter.

1. Unscrew the nut **16** and remove the cover of the air cleaner **17**.
2. Unscrew the wing nut **18** and remove the filter element **19 20**.
Paper filter element **19** :
Tap the hard surface of the filter element for several times to make the dirt fall off or aerate the filter element with compressed air from the inside out to blow off the dirt. Do not brush off the dirt with a brush as doing so will make the dirt fall into the filter paper. Replace the filter element if it is too dirty.
Foam filter element **20** :
Place and wash the foam filter element in liquid detergent and warm water, wrap it in a clean cloth and squeeze it to dry it completely. Then soak it in clean engine oil, take it out wrapping with a clean absorbent cloth and squeeze redundant engine oil.
3. Put back the filter **20 19** element in its assembly.
4. Put the air cleaner cover **17** in place and fix it with nuts **16**.

Spark Plug (Fig. M)

1. Clean any dirt from the spark plug cap and spark plug base.
2. Remove and inspect spark plug.
3. Inspect the spark plug and spark plug washer. If they are damaged or worn, replace. Clean the spark plug with a wire brush if it can be reused.

NOTICE: Replace spark plug if electrodes are pitted, burned or porcelain is cracked. Use only the recommended spark plug (Champion RN9YC or equivalent). The use of a nonrecommended spark plug can result in damage to the engine.

4. Check spark plug gap. Reset spark plug gap to 0.70–0.80 mm.
5. Install spark plug finger tight and tighten an additional 3/8 to 1/2 turn using spark plug wrench. Torque to: 15–20 N.m
6. Attach the spark plug cap to the plug.

Spark Arrestor (Applicable types) (Fig.N)

Your engine is not factory-equipped with a spark arrestor. In some areas, it is illegal to operate an engine without a spark arrestor. Check local laws and regulations. A spark arrestor is available from authorised servicing dealers.

1. Allow the generator to cool completely before servicing the spark arrestor.
2. Remove the two screws holding the cover plate which retains the end of the spark arrestor to the muffler.
3. Remove the spark arrestor screen.
4. Carefully remove the carbon deposits from the spark arrestor screen with a wire brush.
5. Replace the spark arrestor if it is damaged.
6. Reinstall the spark arrestor in the muffler and attach with two screws.

Idle Speed

The idle speed has been pre-set at the factory and should rarely require adjustment.

NOTICE: Improper adjustment of idle speed will damage your engine and may affect your ability to make a claim under any express warranty, [including the Limited Warranty and Emission Control System Warranty], or any warranty implied by operation of law.

Adjustment

Except as described in this manual, there is no additional maintenance or adjustment required for your generator.

Improper adjustments or tampering can damage your engine and your equipment and may affect your ability to make a claim under any express warranty, [including the Limited Warranty and Emission Control System Warranty], or any warranty implied by operation of law.

 **WARNING:** Tampering with the factory set governor will damage your engine and may affect your ability to make a claim under any express warranty, [including the Limited Warranty and Emission Control System Warranty], or any warranty implied by operation of law.

RCD Safety Switch Testing (if Equipped) (Fig. B)

 **WARNING:** If the RCD safety switch fails the TEST function, either by the circuit breaker not moving to the OFF position at all or by doing so in a slow or delayed manner, the generator should not be used. Stop the generator as described in **Stopping the Generator** and take it to your nearest authorised service dealer.

1. Start the generator as described in **Starting the Generator**, but do not connect any electrical cords or devices.
2. Turn the locking screw on the RCD safety switch **13** cover anti-clockwise by hand until the cover is released.
3. Pull forward on the bottom of the RCD safety switch cover and pivot it upwards to open.
4. Check the RCD safety switch circuit breaker is in the upwards ON position.
5. Push TEST button momentarily. The RCD safety switch circuit breaker should instantly flick downwards to the OFF position; this indicates that the RCD safety switch is functioning correctly.
6. If the RCD safety switch passes the TEST function, push the circuit breaker switch back upwards to the ON position. Close the cover and secure it in place by turning the locking screw clockwise by hand. The generator is now ready for use.

Storage and Transportation

 **DANGER:** Gasoline is highly flammable and extremely explosive. Empty the fuel tank before storing or transporting the generator

Storage

The generator should be started at least once every two weeks and allowed to run for at least 20 minutes. Follow the instructions below for longer term storage if the generating set will be out of service for 2 months or more.

1. Allow the generator to cool completely before storage.
2. Clean the generator according to the instructions in the **Maintenance** section.
3. Drain all fuel completely from the fuel hose and carburettor to prevent gum from forming.
4. Turn off the fuel supply at the fuel valve.
5. Change the oil.
6. Reattach the spark plug.
7. Remove the spark plug and pour about 15 ml of oil into the cylinder. Crank the engine slowly to distribute the oil and lubricate the cylinder.
8. Store the unit in a clean, dry area out of direct sunlight.

Transportation

To prevent fuel spillage when transporting or during temporary storage, the generating set should be secured upright in its normal operating position, with the engine switch OFF. The fuel valve lever should be turned OFF.

 **WARNING: When transporting:**

- DO NOT overfill the tank.
- DO NOT operate the generator while it is on vehicle. Take the generator off the vehicle and use it in a well-ventilated place. Avoid a place exposed to direct sunlight when putting the generator on a vehicle. If the generator is left in an enclosed vehicle for many hours, high temperature inside the vehicle could cause fuel to vaporize resulting in a possible explosion.
- DO NOT drive on a rough road for an extended period with the generator on board. If you must transport the generator on a rough road, drain the fuel from the generator beforehand.

Optional Accessories

WARNING: Since accessories, other than those offered by DeWALT, have not been tested with this product, use of such accessories with this generator could be hazardous. To reduce the risk of injury or product malfunction, only DeWALT recommended accessories should be used with this product. Consult your dealer for further information on the appropriate accessories. If you need assistance in locating any accessory for your generator, please contact the FNA Group at, please contact the FNA Group at AUST 1800 841 749 / NZ 0800 467 813.

Protecting the Environment

Separate collection. Products and batteries marked with this symbol must not be disposed of with normal household waste.

Products and batteries contain materials that can be recovered or recycled reducing the demand for raw materials. Please recycle electrical products and batteries according to local provisions. Further information is available at www.2helpU.com.

TROUBLESHOOTING

WARNING: Before attempting to service or troubleshoot the generator, the owner or service technician must first read and understand the instruction manual and comply with all safety instructions. Failure to follow all instructions may result in conditions leading to voiding of the product warranty, serious personal injury, property damage or even death.

| PROBLEM | CAUSE | CORRECTION |
|---|---|--|
| Engine is running, but AC output is not available. | Circuit breaker OPEN. | Reset circuit breaker. |
| | Poor connection or defective cord set. | Check and repair. |
| | Connected device is bad. | Connect another device that is in good condition. |
| | Fault in generator. | Contact an authorised DeWALT repair agent. |
| | RCD safety switch circuit breaker (if equipped) is in the OFF position. | Move RCD safety switch circuit breaker (if equipped) to the ON position. |
| Engine runs well at no load, but bogs when load is applied. | Short circuit in a connected load. | Disconnect shorted electrical load. |
| | Generator is overloaded. | See Know Generator Limits . |
| | Engine speed is too slow. | Contact an authorised DeWALT repair agent. |
| | Shorted generator circuit. | Contact an authorised DeWALT repair agent. |
| | Dirty fuel filter. | Replace fuel filter. |
| Engine will not start; or starts and runs rough. | Fuel shutoff is OFF. | Turn fuel shutoff ON. |
| | Dirty air filter. | Clean or replace air filter. |
| | Out of fuel. | Fill fuel tank. |
| | Stale fuel. | Drain fuel tank and fill with fresh fuel. |
| | Spark plug wire not connected to spark plug. | Connect wire to spark plug. |
| | Bad spark plug. | Replace spark plug. |
| | Water in fuel. | Drain fuel tank; fill with fresh fuel. |
| | Over choking. | Set choke to no choke position. |
| | Low oil level. | Fill crankcase to correct level. |
| | Excessive rich fuel mixture. | Contact an authorised DeWALT repair agent. |
| | Intake valve stuck open or closed. | Contact an authorised DeWALT repair agent. |
| | Engine lost compression. | Contact an authorised DeWALT repair agent. |
| Engine shuts down during operation. | Out of fuel. | Fill fuel tank. |
| | Low oil level. | Fill crankcase to correct level. |
| | Fault in engine. | Contact an authorised DeWALT repair agent. |
| Engine lacks power. | Load is too high. | Reduce load (see Know Generator Limits). |
| | Dirty air filter. | Clean or replace air filter. |
| | Engine needs to be serviced. | Contact an authorised DeWALT repair agent. |
| | Choke is partially closed. | Set choke lever to no choke position. |
| | Dirty fuel filter. | Replace fuel filter. |
| Engine surges or stumbles. | Choke is opened too soon. | Set choke to halfway position until engine runs smoothly. |
| | Carburetor is running too rich or too lean. | Contact an authorised DeWALT repair agent. |
| | Dirty fuel filter. | Replace fuel filter. |

| PROBLEM | CAUSE | CORRECTION |
|---|---|--|
| RCD safety switch turns itself OFF (if equipped). | Electrical fault in connected cord(s) or device(s). | Disconnect all electrical cords and devices from generator and switch all AC circuit breakers OFF. Reset RCD safety switch to ON position. Reconnect and test run loads individually. Any faulty cord or device that trips the RCD safety switch again must not be used further until checked and approved by a licensed electrician |
| | Generator is connected to a fixed multiple earthed neutral (MEN) electrical installation. | Disconnect the generator from the MEN electrical installation and instead power the electrical device(s) by detachable plug and socket-outlet connection. |
| | If above possible causes are checked and eliminated, generator may be faulty | Contact an authorised DeWALT repair agent. |

LIMITED WARRANTY

Where the purchaser of this product is in Australia and is a consumer under Australian Consumer Law, the warranty provisions herein are to be read in addition and subject to the consumer guarantees provided in Australian Consumer Law unless excluded in accordance with that Law.

Where the purchaser of this product is in New Zealand, the warranty provisions herein are to be read subject to the terms of the NZ Consumer Guarantees Act 1993 unless excluded in accordance with that Act.

The manufacturer warrants to the original retail purchaser that this outdoor product is free from defect in material and workmanship and agrees to repair or replace, at the manufacturer's discretion, any defective product free of charge within the following time periods from the date of purchase:

- 1) Three (3) years, if the product is used for personal, family or household use; and
- 2) Six (6) months, if used for any other purpose, such as commercial or rental use.

This warranty extends to the original retail purchaser only and commences on the date of the original retail purchase.

This warranty does not cover any product that has been subject to abuse, misuse, neglect, negligence, accident, the effects of corrosion or erosion, or that has been operated in any way contrary to the operating instructions as specified in this operator's manual. This warranty does not apply to any damage to the product that is the result of improper maintenance or to any product that has been altered or modified. The warranty does not extend to repairs made necessary by normal wear or by the use of parts or accessories which are either incompatible with the outdoor product or adversely affect its operation, performance, or durability.

In addition, this warranty does not cover:

Tune-ups - Spark Plugs, Carburetor Adjustments, Ignition, Filters, Oil Change
Wear items-Recoil Starter Rope, Motor Brushes, Alternator Brushes.

TO THE EXTENT PERMITTED BY LAW, ALL IMPLIED WARRANTIES ARE LIMITED IN DURATION TO THE STATED WARRANTY PERIOD. ACCORDINGLY, ANY SUCH IMPLIED WARRANTIES INCLUDING MERCHANTABILITY, FITNESS FOR A PARTICULAR PURPOSE, OR OTHERWISE, ARE DISCLAIMED IN THEIR ENTIRETY AFTER THE EXPIRATION OF THE APPROPRIATE THREE-YEAR OR SIX-MONTH WARRANTY PERIOD.

THE MANUFACTURER'S OBLIGATION UNDER THIS WARRANTY IS STRICTLY AND EXCLUSIVELY LIMITED TO THE REPAIR OR REPLACEMENT OF DEFECTIVE PARTS AND THE MANUFACTURER DOES NOT ASSUME OR AUTHORIZE ANYONE TO ASSUME FOR THEM ANY OTHER OBLIGATION.

TO THE EXTENT PERMITTED BY LAW, THE MANUFACTURER ASSUMES NO RESPONSIBILITY FOR, AND THE ORIGINAL RETAIL PURCHASER MUST BEAR THE EXPENSES OF, INCIDENTAL, CONSEQUENTIAL, OR OTHER DAMAGES INCLUDING, BUT NOT LIMITED TO, EXPENSE OF RETURNING THE PRODUCT TO AN AUTHORIZED SERVICE CENTER AND EXPENSE OF DELIVERING IT BACK TO THE OWNER, MECHANIC'S TRAVEL TIME, TELEPHONE OR TELEGRAM CHARGES, RENTAL OF A LIKE PRODUCT DURING THE TIME WARRANTY SERVICE IS BEING PERFORMED, TRAVEL, LOSS OR DAMAGE TO PERSONAL PROPERTY, LOSS OF REVENUE, LOSS OF USE OF THE PRODUCT, LOSS OF TIME, OR INCONVENIENCE.

Our products come with guarantees that cannot be excluded under either:

- 1) The NZ Consumer Guarantees Act 1993; or
- 2) Australian Consumer Law.

In New Zealand, you are entitled to repair or replacement, or damages for any reduction in the value of the goods resulting from any failure to meet the guarantees in that Act and for any other reasonably foreseeable loss or damage arising. In Australia, you are entitled to a replacement or refund for a major failure and for compensation for any reasonably foreseeable loss or damage. You are also entitled to have the goods repaired or replaced if the goods fail to be of acceptable quality and the failure does not amount to a major failure. The manufacturer will honor the terms of all component warranties and satisfy claims of the appropriate warranty provisions through a network of factory authorized and trained Warranty Service Centers. To make a claim under the terms of the warranty, all parts said to be defective must be retained and available for return upon request to a designated Warranty Service Center for warranty inspection. The judgments and decisions of the manufacturer concerning the validity of warranty claims, under this Limited Warranty, are final.

For any product subject to a warranty claim, please call the phone numbers listed below for specific warranty instructions, procedures, and information regarding the Warranty Service Centers.

You must present proof of purchase when making a warranty claim.

Australia Phone : 1800 841 749

New Zealand Phone : 0800 467 813

FNA Group, Inc. / Mayo Hardware PTY LTD

4 Secombe Place Moorebank NSW 2170

Australia

Circuit Diagrams

DXGC4150i

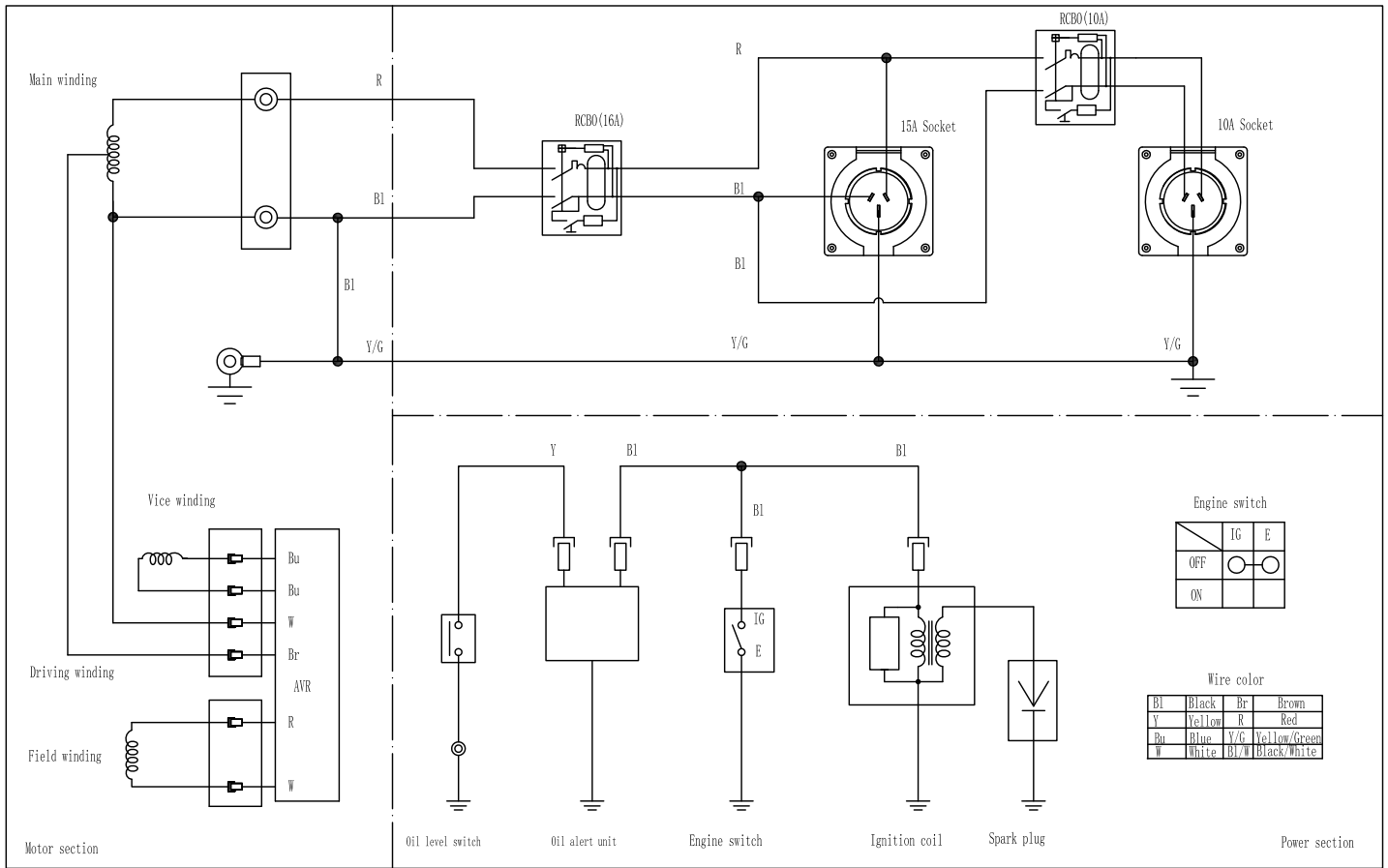

DXGC8250i

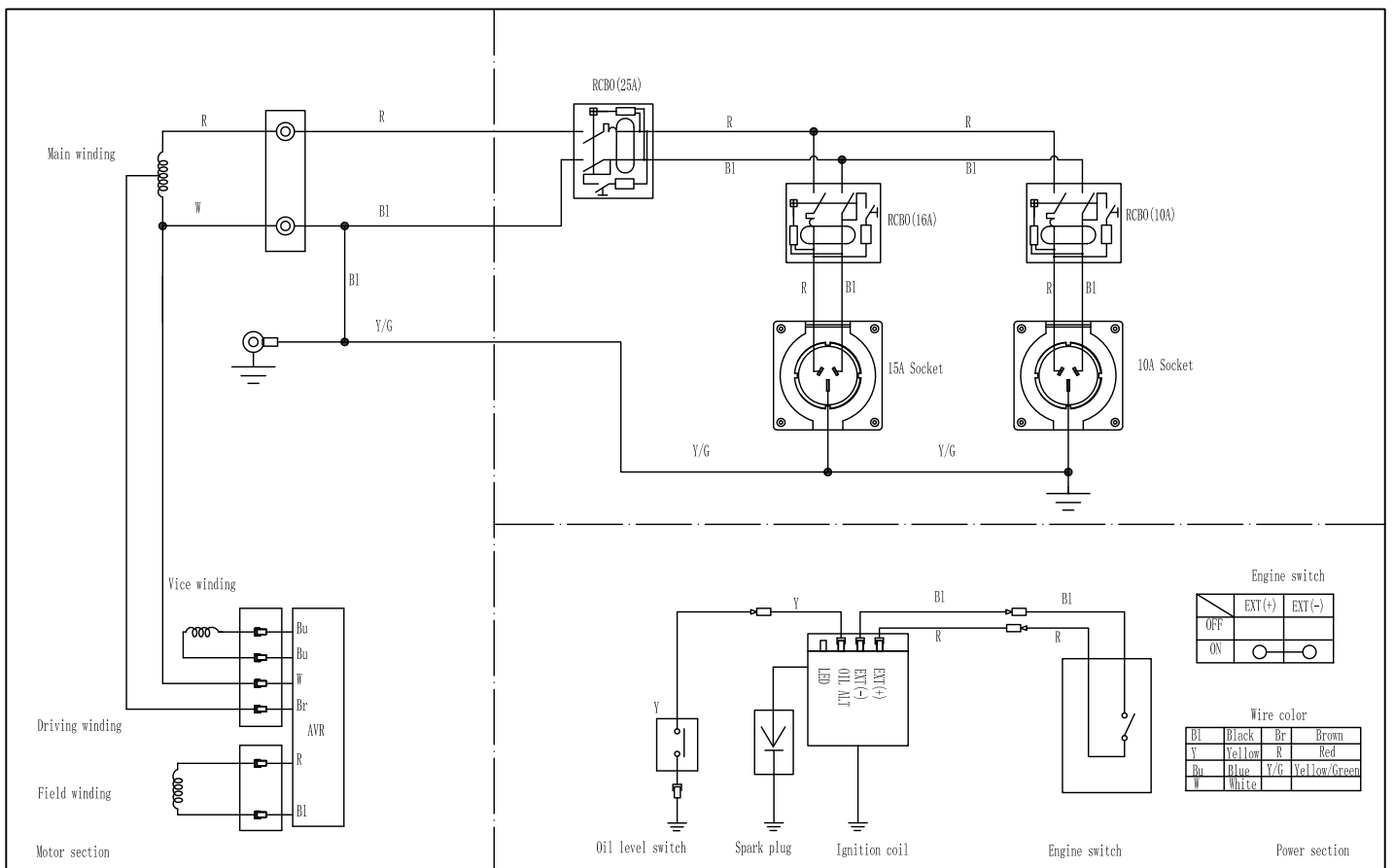

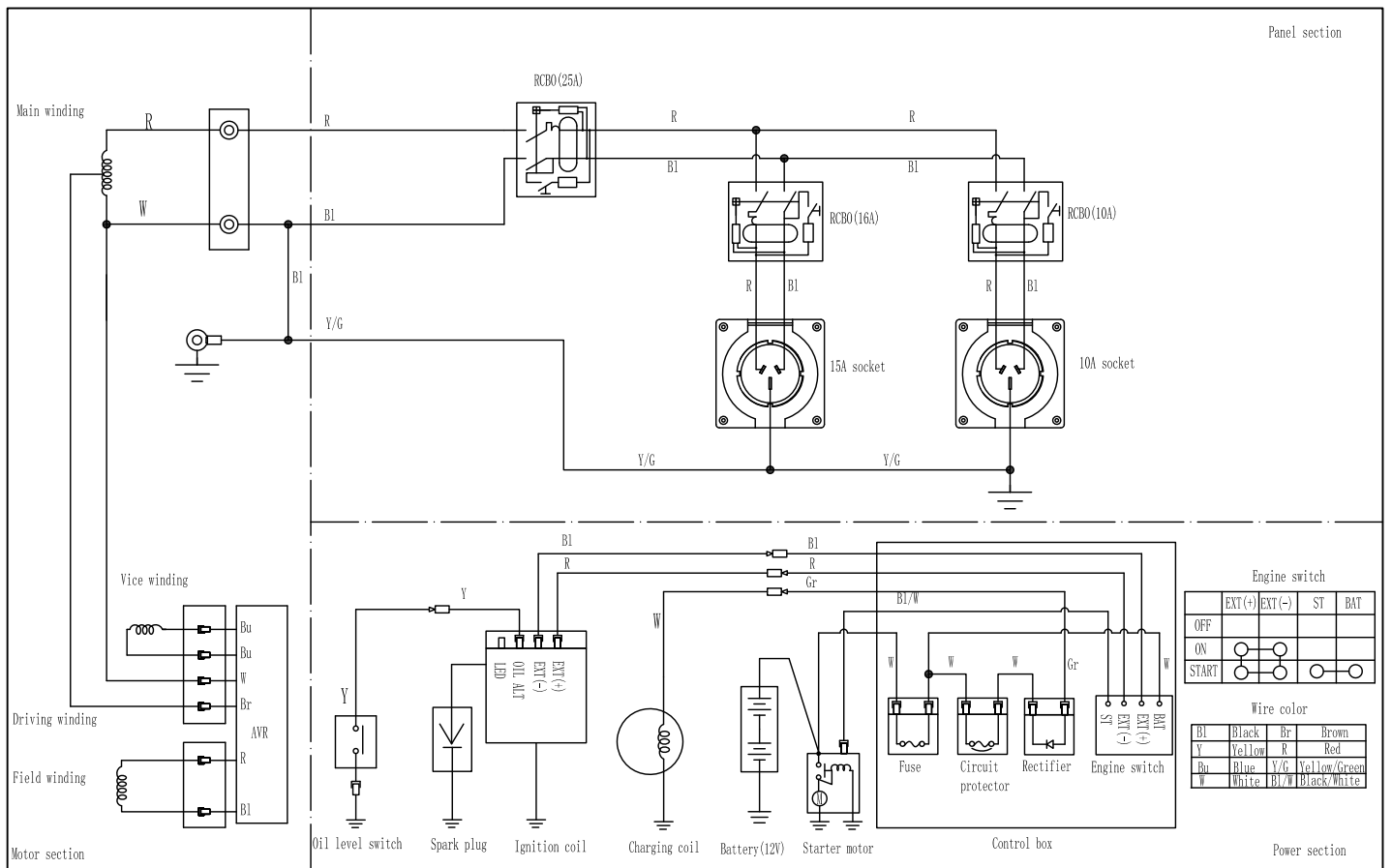

Panel section

Motor section

Engine switch

| | EXT(+) | EXT(-) | ST | BAT |
|-------|--------|--------|----|-----|
| OFF | | | | |
| ON | ○ | ○ | ○ | ○ |
| START | ○ | ○ | ○ | ○ |

Wire color

| | | | |
|----|--------|------|--------------|
| Bl | Black | Br | Brown |
| Y | Yellow | R | Red |
| Br | Blue | Y/G | Yellow/Green |
| W | White | Bl/W | Black/White |

Power section