

88DU

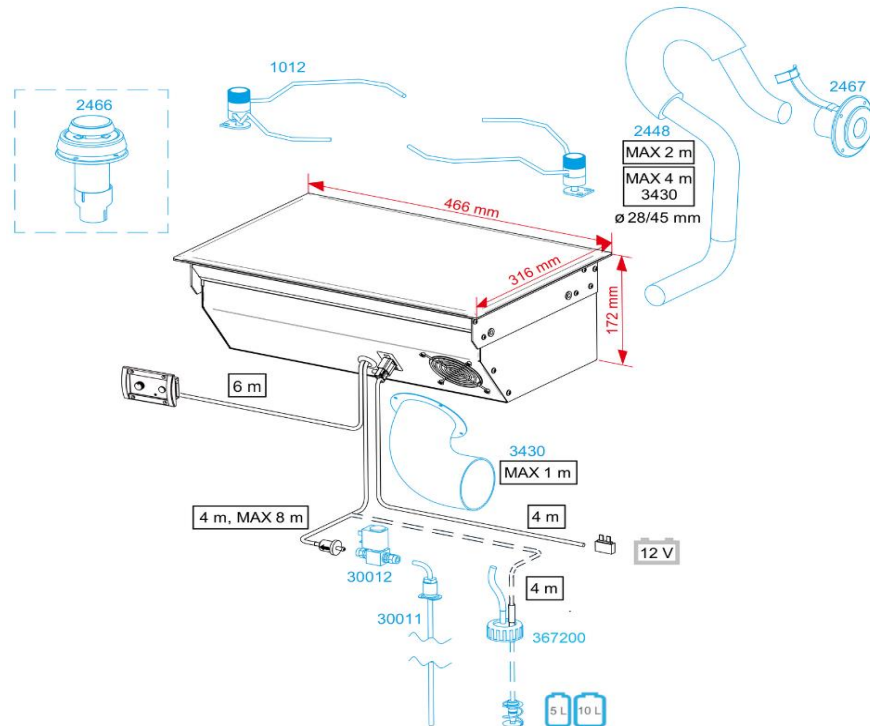

Installation, operation and maintenance instructions

Technical information



Package contents

88DU

1 pcs		Stove 88DU (fuel hose and control panel cable installed)
1 pcs	①	Control panel
1 pcs	②	Power cord with connector (4 m)
2 pcs	③	Iron fastener
1 pcs		Accessory bag
	2 pcs	④ Control panel fastening screws 3.5 x 13 (black)
	4 pcs	⑤ Screw for iron fastener M6 x 12 (hexagonal socket 4 mm)
	4 pcs	⑥ Fastening screw M6 x 30 (hexagonal socket 4 mm)
	4 pcs	⑦ Locking nut M6
	4 pcs	⑧ Cover plug
	1 pcs	⑨ Hose binder 20 – 32 mm
	1 pcs	⑩ Fuse box
	1 pcs	⑪ Fuse 15 A (blue)
	2 pcs	⑫ Push on contact 6.3 x 0.8 (yellow)
1 pcs		Pipe connection box kit
	1 pcs	⑬ Pipe connection box
	1 pcs	⑭ Hose binder 32 – 50 mm
	1 pcs	⑮ Tightening screw M4 x 8
1 pcs		Fuel filter package
	1 pcs	⑯ Fuel filter
	4 pcs	⑰ Hose binder 8 mm
	2 pcs	⑱ Hose binder 10 mm
	2 pcs	⑲ Rubber hose ø 5 mm
	1 pcs	⑳ Rubber hose ø 6 mm
1 pcs		Installation, operation and maintenance instructions

Technical information

Stove operation

The 88DU is a safe diesel stove with no open flame. The stove is equipped with a single burner which burns either diesel oil or light furnace oil. The stove takes the air needed for the burning process from the boat and discharges the resultant smoke with a combustion air blower. This means that, when the stove is being used, the air in the boat circulates and stays fresh and dry. The steam in the flue gas does not remain in the boat and increase interior humidity.

The fuel pump in the stove dispenses fuel, and the electronics control the combustion air and the amount of fuel automatically to keep the flame of the burner clean. When the stove is switched on, the glow plug in the burner ignites the fuel that has been pumped into the burner. The glow time is fixed: it begins and ends automatically.

The heat sensor in the stove detects the heat of the flame and lights the red LED light to signal that the flame has been ignited.

The heat which is released as the fuel burns is transferred into the ceramic stove top. The left side of the stove top is hotter, as the burner is located under it. The power of the stove can be adjusted steplessly. The control adjusts both sides of the stove simultaneously.

When the stove is switched off, it cools down automatically. The cooling function ventilates the burner and discharges the flue gases generated during the switch-off outside the boat.

The stove lends itself extremely well to cooking and warming up all kinds of foods. It has been manufactured entirely from stainless materials.

Technical information

Fuel	Diesel oil, light furnace oil
Operating voltage	12 V DC
Consumption	0,09 - 0,19 l/h
Heating power	900 - 1900 W
Power consumption	0.3 A (when ignited ca. 4 min. 8 A)
Measurements	466 x 316 x 172 mm
Weight	ca. 9 kg
Max. permissible length of the flue gas pipe	2 m (4 m, Intake connection set 3430)
Max. permissible length of the fuel hose	8 m
Minimum size of the replacement air opening	100 cm ²
Suitable flue gas lead-throughs	2467 , and 2460
Accessories	1012 Kettle holder set 1150 Toasting grill 3430 Intake connection set

Things to note when selecting the installation location

When installing the device, bear in mind that the device must be detached for maintenance. Therefore, it is advisable to make the connections easy to open and disconnect.

The stove should be installed level. The inclination must not exceed 5°. While the device might not break if it is temporarily tilted to a steep angle (even for some hours), the burner will not yield optimal performance if it is constantly inclined. Also consider where you will place the control panel, as the length of the control panel's cable may pose some limitations.

Avoid installing the control panel in the immediate vicinity of a water outlet.

If possible, install the control panel on a vertical surface.

Moreover, the stove should not be installed on top of a refrigerator. The stove will heat its surroundings and thus decrease the power of the refrigerator.

We recommend that the device be installed by an authorised Wallas service shop.

Things to note when installing pipes, hoses and cables

Power cables and fuel hoses must be protected in locations where they are susceptible to mechanical damage due to sharp edges or heat.



In a metal-hulled boat, you must ensure that the device, the flue gas lead-through, the fuel connection, the control panel, and all other parts are insulated from the boat's hull. This must be done to:

- prevent electrochemical corrosion
- prevent voltage from being transmitted from the hull to the device or vice versa during electrical faults.



Always use original Wallas accessories and parts with Wallas equipment.

Stove installation

Saw a cut-out (see picture) for the stove and the control panel in your chosen location.

The length of the control panel cable is 2 m.

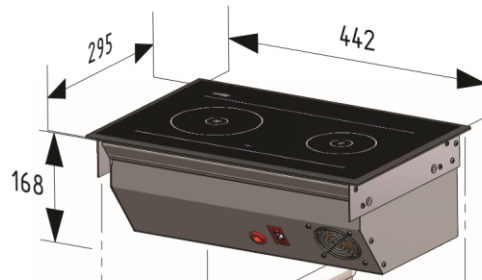

The stove requires a replacement air opening of at least 100 cm². Ensure that the air circulation under the stove is sufficient

You can also fabricate a detachable panel to go in front of the stove. This will facilitate installation and maintenance.

Ensure that there is sufficient space under the stove for cables and hoses.

The control panel should be installed on a vertical surface.

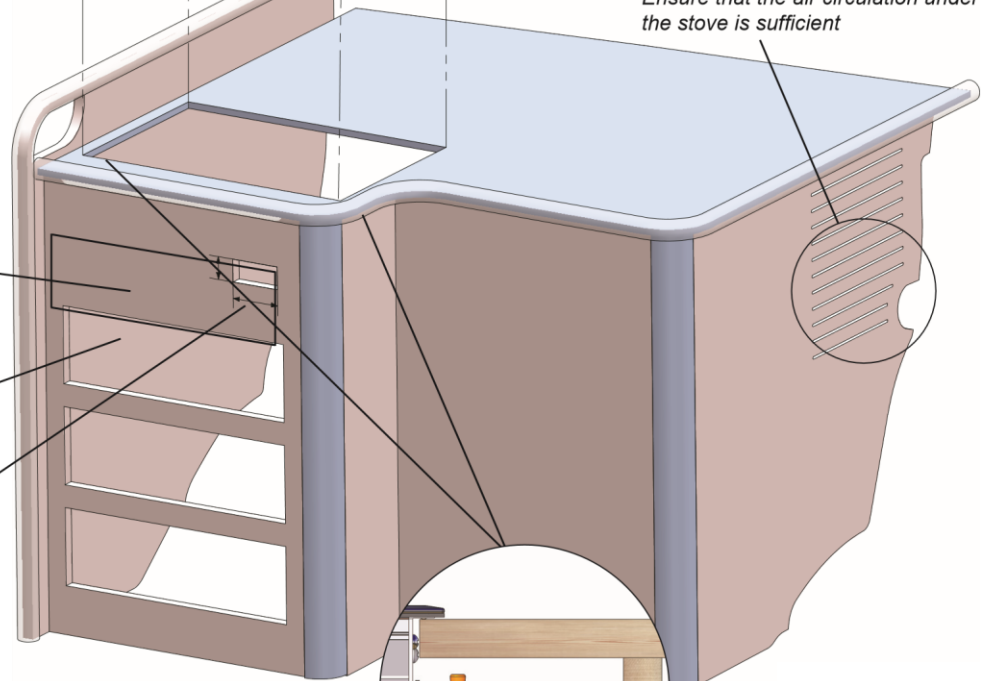

Ensure that there is sufficient space between the stove and the vertical surface to facilitate installing and detaching the device.

Measurements of the control panel cut-out hole:

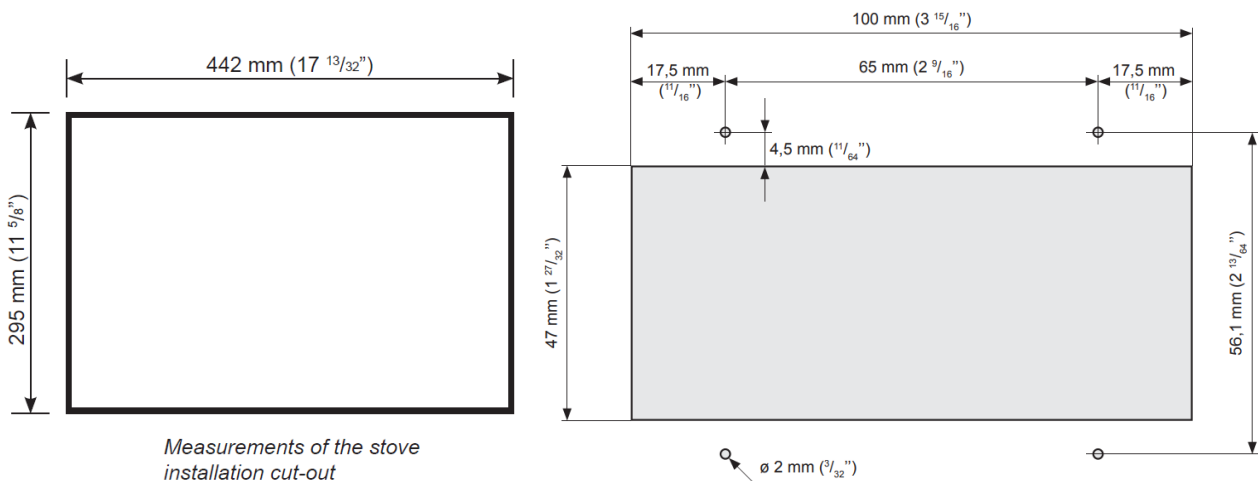

Installing in demanding conditions

If the device is installed or will be used in demanding conditions, e.g.

- the flue gas hose is 2 to 4 meters long, the stove
- is surrounded by thick thermal insulation,
- there is another heat source under the stove (e.g. a Wallas oven 86D or a refrigerator),
- the climate is particularly warm, the intake connection set

3430 must be installed on the stove.

Install the set in front of the blower in the stove's cooling case.

Lead the \varnothing 75 mm hose (max length 1 m) to a location with fresh air. Ensure that the air flows freely into the hose. Do not crimp the hose.

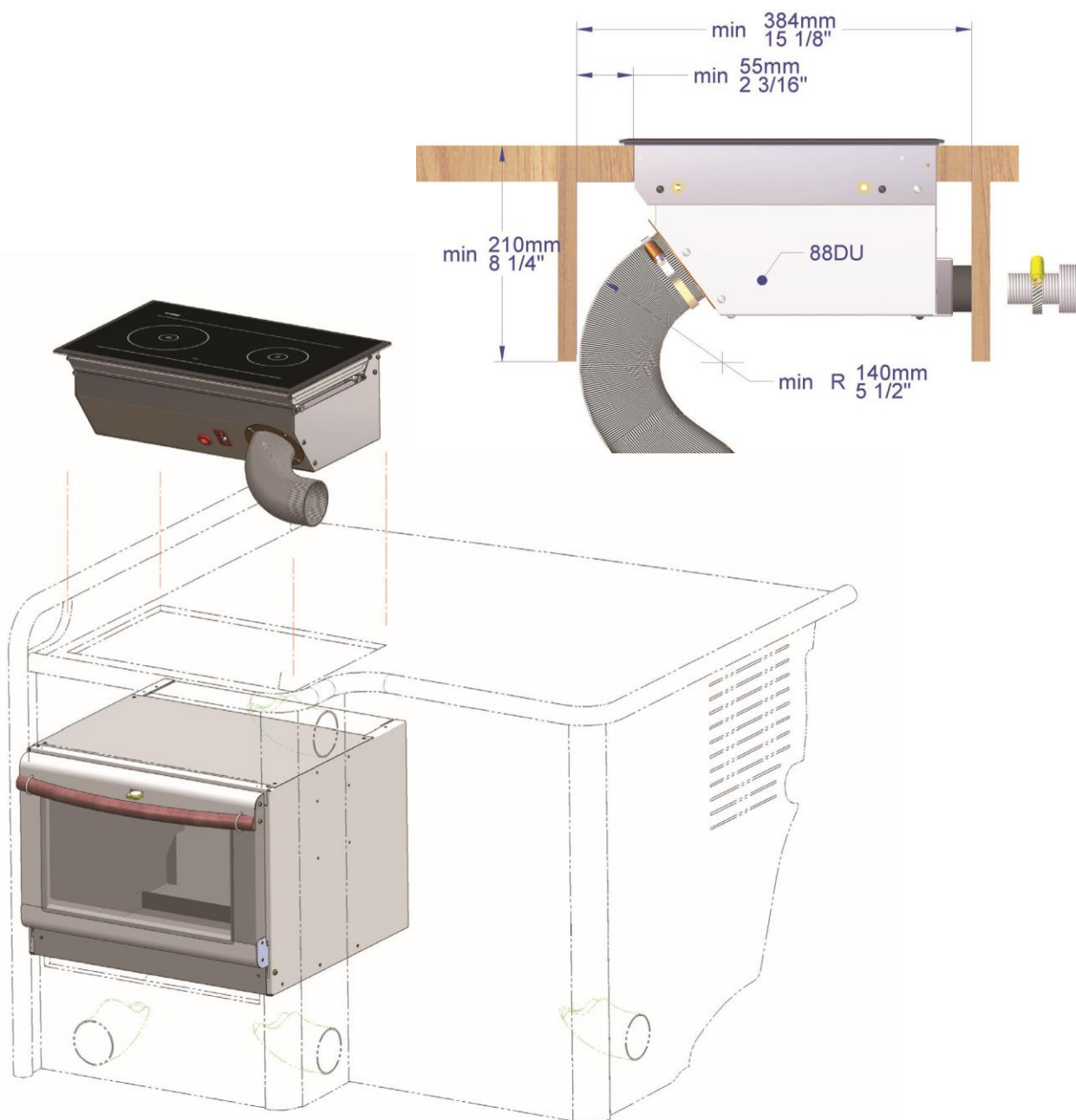

Fastening the device

Place the stove in the installation cut-out and attach the iron fasteners (3) with the screws (5) to the rivet nuts at the ends. After this, install the cover plug (8) on the end of the screw and tighten the iron fasteners against the table with the screw (6). Remember the locking nuts (7).

Use the screws (4) in the accessory bag to fasten the control panel to the table.

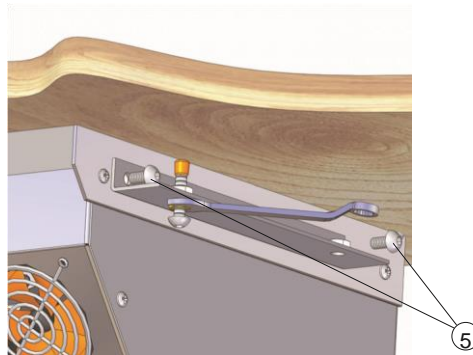
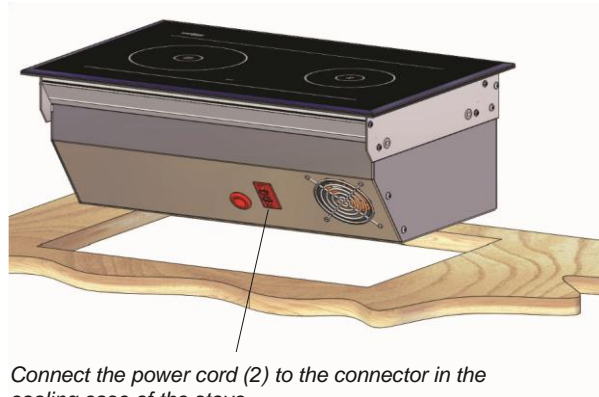

Attach the iron fasteners to the stove (3) with screws (5).

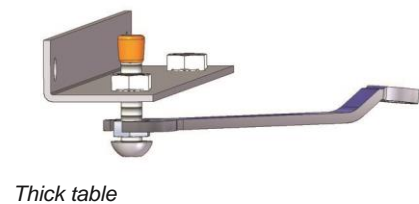
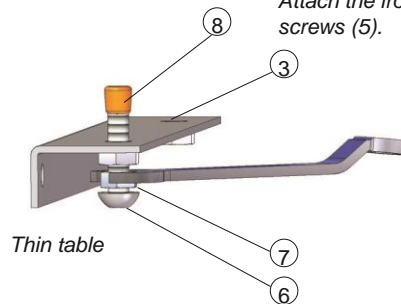

The iron fasteners can be installed in two ways depending on the thickness of the table board.

Push the cover plug (8) on the screw.

Tighten the screw (6) firmly against the table board and then tighten the locking nut (7).

Installation of the flue gas pipe

Measure the length of the flue gas and exhaust pipe from the device to the gas lead-through. Remember to add the required length for the swan neck section. Cut the flue gas pipe 30–50 mm longer than the exhaust pipe. This way the pipe will stay in place in the gas lead-through more firmly.

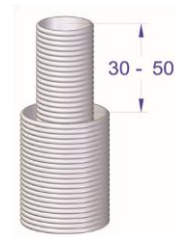
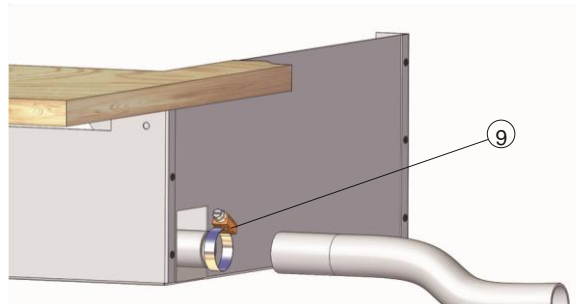

Connect the flue gas pipe (\varnothing 28 mm) to the device using the hose binder (9) in the accessory bag.

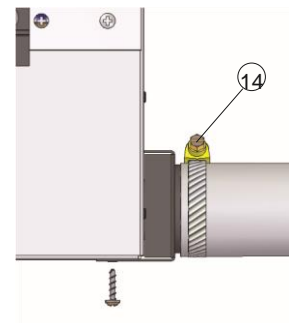
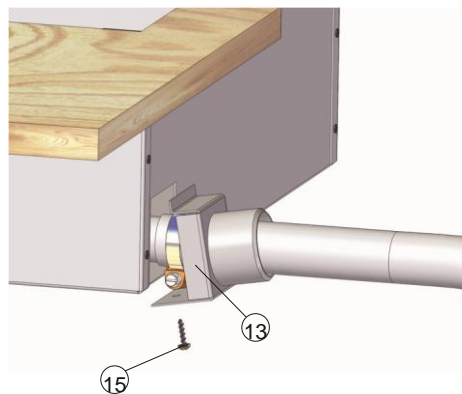

Attach the connection box of the exhaust pipe (13) cooling case of the stove with a screw (15). binder (14).

Connect the exhaust (\varnothing 45 mm) to the connection box with a hose

ELECTRICAL CONNECTIONS

Things to note about the connections

The device uses 12V direct current voltage. To minimize current losses, make the power cable as short as possible and avoid jointing. The cross-sectional area of the cable is dependent on the length of the power cord. See table 1. The cross-sectional area of the cable must be consistent all the way from the stove to the battery. The maximum length of the power cord is 10 m.

Total length of the power cord (m)	Cross-sectional are of the cable (mm ²)
0 - 4	4
4 - 6	6
6 - 10	10

Table 1.

If a thicker cable is required, make a separate joint in the power cord. See picture 1 on the next page.

Main switch

A main switch (accessory) must be installed on the device's plus cord. Always cut the power at the main switch, if the device is going to be left unused for a longer period of time.



Never use the main switch to cut the power before the cooling phase, which starts after stove is turned off, is completed.

Electrical connections of the device

12V direct current system

Connect the red wire of the power cord to the plus terminal of the battery and the black or blue wire to the minus terminal. A 15 A main fuse must be installed near the battery on the red plus wire of the power cord. See picture 1.

24V direct current system

If the device is to receive power from a 24V system, always connect a charging voltage reducer and a 12V battery before connecting the device. Without the battery the voltage reducer will not be enough on its own as it cannot generate the large amount of current the glow plug requires. After the 12V battery, the connection is the same as in a 12 V system.

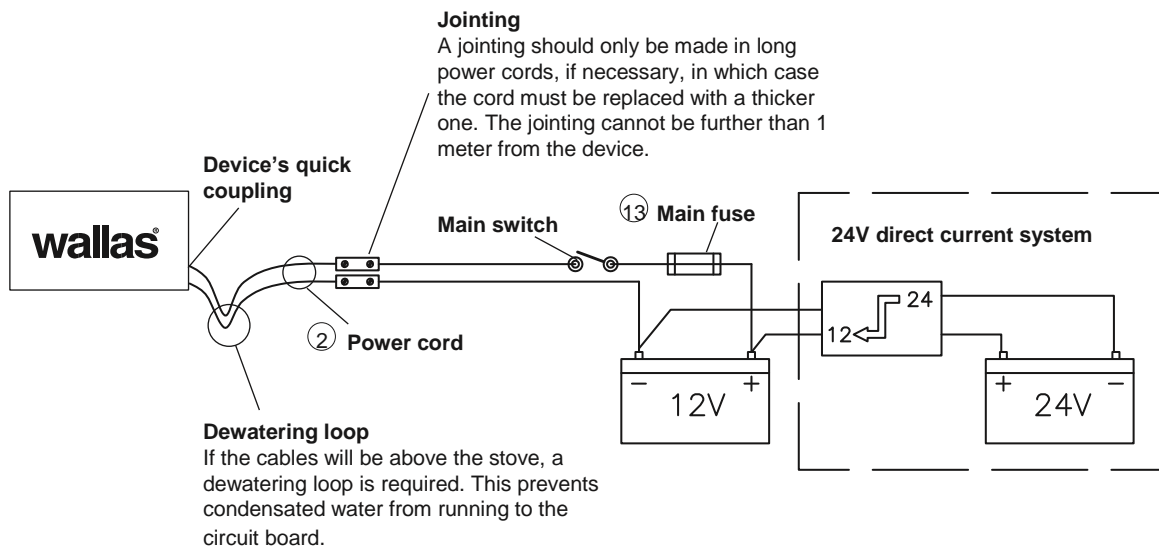

Picture 1.

Checking the connection

The device consumes most power when it is started up (glowing). At this point voltage losses are also at their highest. During the glowing phase, the voltage must be at least 10.7 V measured at the quick coupling. See picture 1. If the voltage is lower than this, the device may not start.



If you handle an electronics card detached from the device, take care to avoid damage due to static electricity.

FUEL CONNECTIONS

Things to note about the connections

The standard length of the fuel hose is 4 m (max 8 m). Cut the fuel hose to a length suitable for installation.

The lift height of the pump should be less than 2 m; preferably 0.5 – 1 m. The fuel pipe must always have a filter. The fuel filter can be installed either near the device, near the tank, or in another location where it can be easily checked and replaced, when necessary.

All connections should be made with rubber or silicone hose which is resistant to diesel.

Country-specific requirements

The standard fuel hose is plastic. Please observe country-specific requirements with regard to the material of the fuel hose/pipe and the fuel filter. The inner diameter of a new replacement hose must be equal to the inner diameter of the plastic hose.

Copper pipe and metal filters are available as accessories.

Fuel feed

If the lift height is outside the recommended 0.5 – 1 m, the fuel feed must be checked and, if necessary, adjusted. The fuel feed must also always be checked, if parts of the fuel system, such as the pump or the electronics card, have been replaced.

Fuel system adjustments are device specific. We recommend that the adjustment be carried out by an authorised service shop.

Optimal fuel tank location

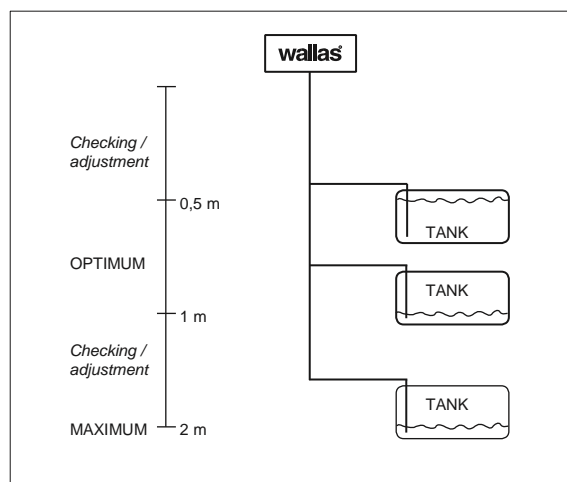



The fuel connections must be tightened firmly so as to not allow air to leak into the hose. Always check the cleanliness of the connection surfaces before tightening.

Air will cause the device to malfunction.

Connection to a fixed tank

If the boat's fixed tank is used for the stove, the stove must not be fed through the same connection as the engine. The stove must have a separate connection as well as a fuel filter outside the tank. If necessary, the fuel line can be branched off with a T piece to the Wallas diesel-operated device.

Installation instructions for Tank connection 30011 (accessory)

1. Make a \varnothing 25 mm hole in the upper surface of the fuel tank.

Choose the location of the hole so that when the boat tilts the end of the intake pipe will stay in the fuel even if the tank is not full. If the end of the intake pipe does not reach the fuel, the device will quickly choke on the air in the fuel system.

2. Cut the fuel intake pipe (\varnothing 6 mm) to the appropriate length. The end of the pipe must not touch the bottom of the tank in order to keep water and sediment from the system. It is recommended to cut the pipe short enough to leave the engine intake pipe at a lower level. This way the stove cannot empty the tank.

3. Push the cover plug (16) in place.

4. Connect the fuel hose to the heater.

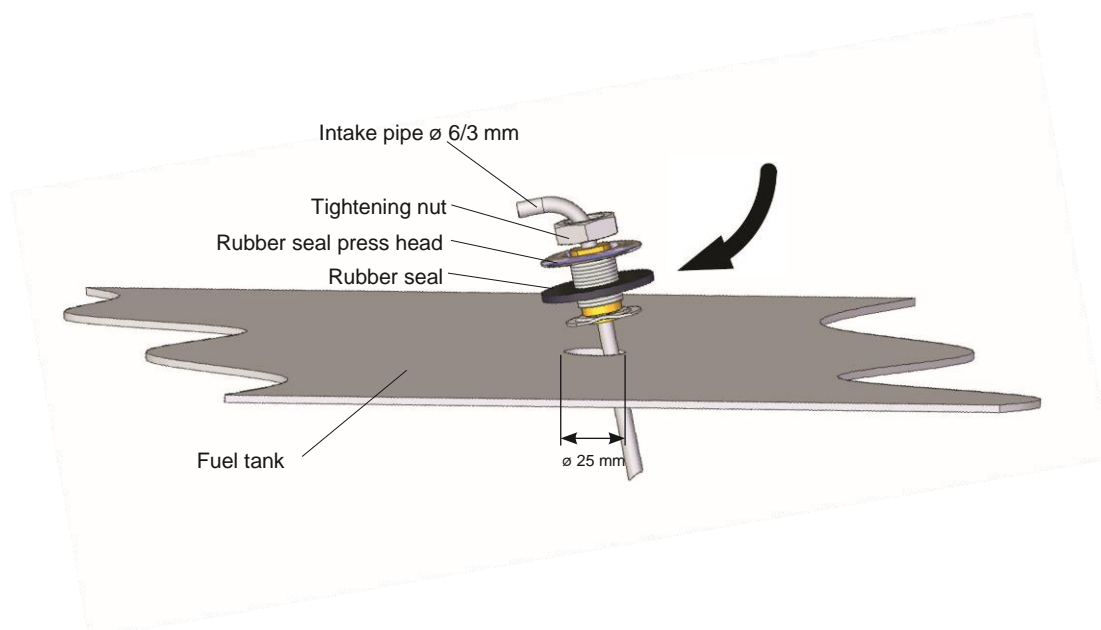

Connection to a separate tank

Cap run-throughs and sinter filters are used on plastic tanks.

Volume	length x height x width	Order code	
5 l	200 x 300 x 130	2024	(accessory)
10 l	380 x 195 x 210	2027	(accessory)
30 l	590 x 200 x 300	4030	(accessory)
130 l	800 x 400 x 600	4130	(accessory)

Wallas fuel tanks

Installation instructions for Tank connection 367215 (accessory)

If the fuel will be taken from a separate tank, you must install a tank connection **367215**.

There are two methods to install the tank connection to the stove.
The recommended way is to use the stove's own fuel hose.

1. Detach the sinter bronze filter from the tank connection hose and pull the fuel hose from the cap.
2. Thread the stove's fuel hose through the connector in the tank cap. This is easier, if you use, for instance, soapy water to lubricate the hose.
3. Install the filter at the end of the hose.
4. Install the tank connection in the tank.

This installation method does not involve opening the cooling box of the stove or the factory connection to the fuel pump.

An alternative way to install the tank connection:

1. Open the cooling case of stove and detach the stove's standard fuel hose from the fuel pump.
2. Thread the tank connection hose through the hole in the cooling case lid.

3. Install the tank connection hose by first threading the barrel nut to the hose, after which the support sleeve should be placed inside the hose and the olive at the end of the hose.
4. Tighten the barrel nut tightly to the fuel pump connector. Keep the parts and the hose clean and ensure that the connection is tight, because an air leak in the connector will stop the device from functioning.
5. Install the cooling case back to the stove.

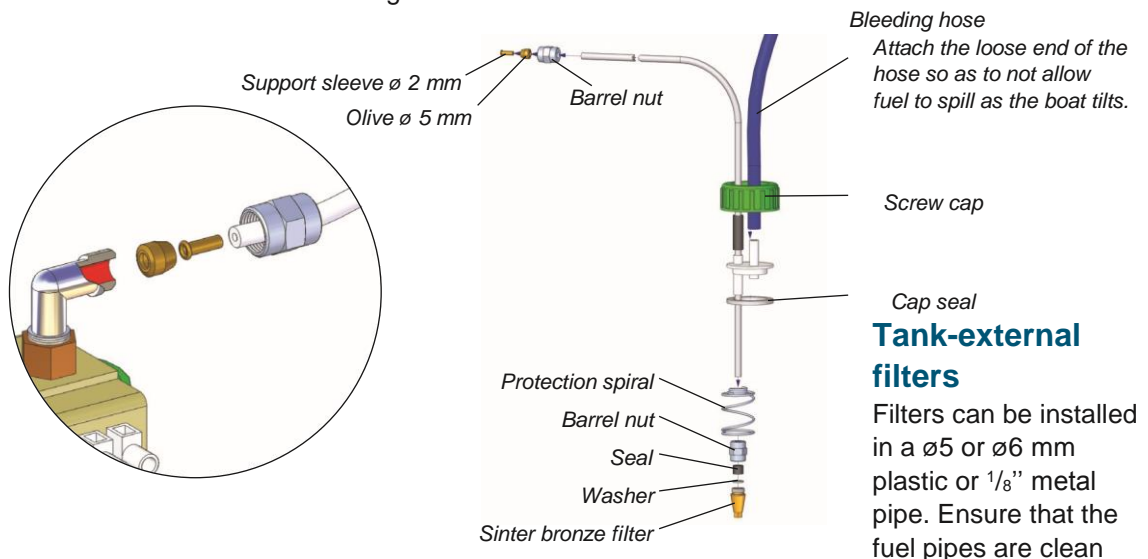

before installing the filter. There must be no debris or impurities between the pump and the filter as they will clog the pump. The filter type must be selected according to the operating conditions and country-specific requirements.

Fuel filter 30015

The filter is supplied with the stove.

The filter can be installed directly in the **30011** tank connection by using a \varnothing 6 mm rubber hose (20) and 10 mm hose binders (18).

Alternatively, the filter can be installed between two \varnothing 5 mm fuel hoses with \varnothing 5 mm rubber hose (19) and \varnothing 8 mm hose binders (17).

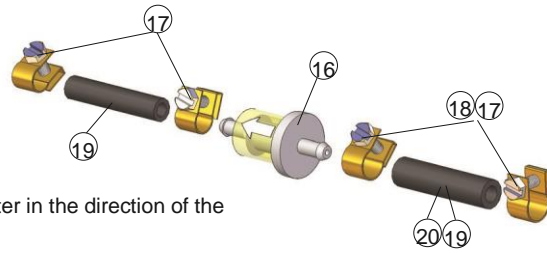
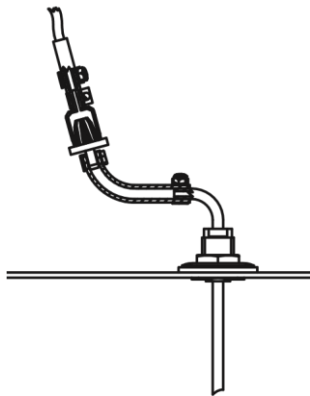
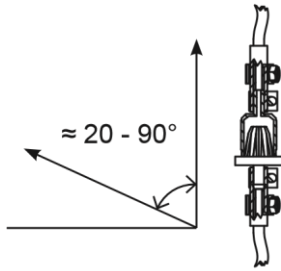
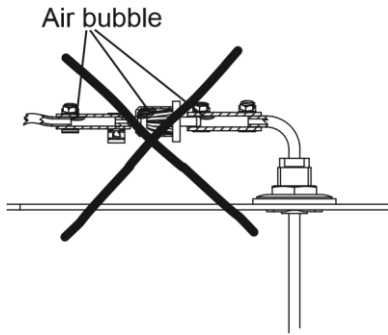

Fuel filter
30014

Install the filter in the direction of the arrow on it.

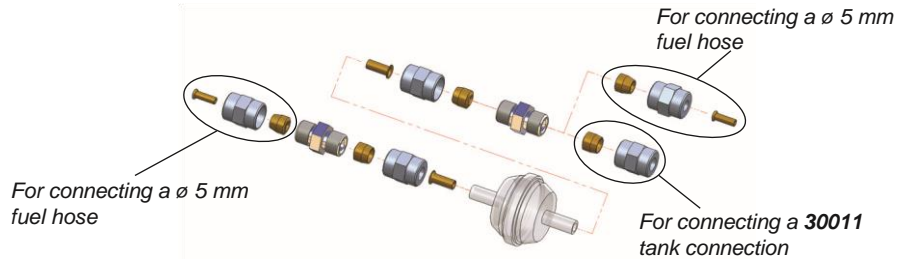

(accessory)

This filter is intended for cold conditions.

The filter can be installed directly in the 30011 tank connection by using a \varnothing 6 mm barrel nut and 6 mm olive.

Alternatively, the filter can be installed between two \varnothing 5 mm fuel hoses with \varnothing 5 mm barrel nut, \varnothing 5 mm olive and \varnothing 2 mm support sleeve.

Fuel filter 30016 (accessory)

Used in countries where a metallic fuel transfer system is required. A 1/8" metal pipe is used for the installation.

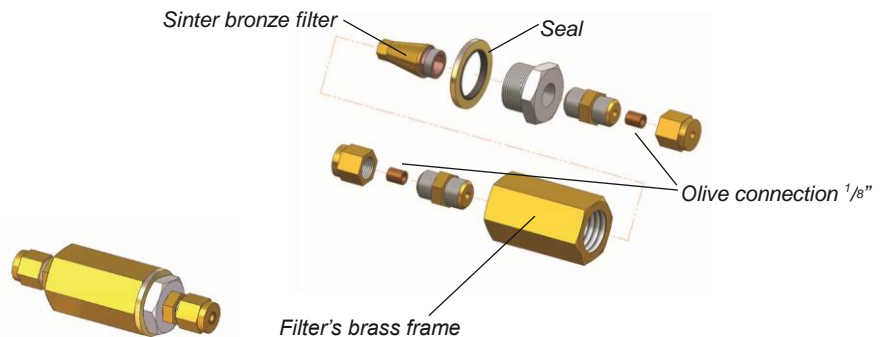

Installation instructions for Solenoid valve 30012 (accessory)

The solenoid valve (30012) prevents the tank from emptying in case the fuel line breaks.

The fuel filter should be installed before the solenoid valve.

In a fuel hose with a T branch, the solenoid valve must function with both connected devices. Connect the solenoid valve to a relay group (accessory) and the relay group to the devices.

Two devices can also be installed to the fuel system by connecting both devices through their own tank connections and solenoid valves. This way the relay group is not required.

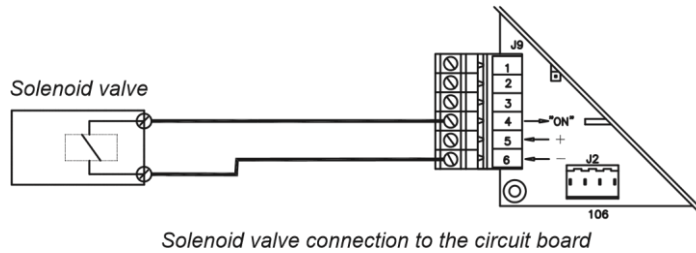

Our recommendations in the following installation scenarios:

1. Fuel level is below the heater/stove.
Picture 1.

- Recommended installation scenario
- No special accessories required

2. Fuel level may temporarily rise above the heater/stove (e.g. in the fuel tank filler pipe or when the boat tilts). Picture 2.

- No special accessories required

3. Fuel level is above the heater/stove.
Picture 3.

- Non-recommended installation scenario
- Solenoid valve (**30012**) must be installed in the fuel hose near the tank

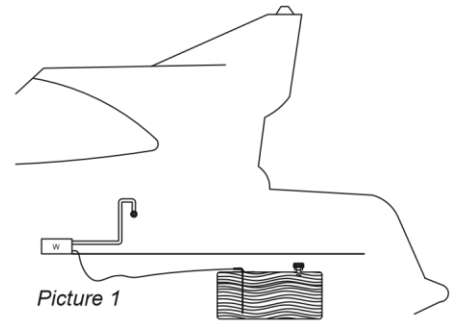

Picture 1

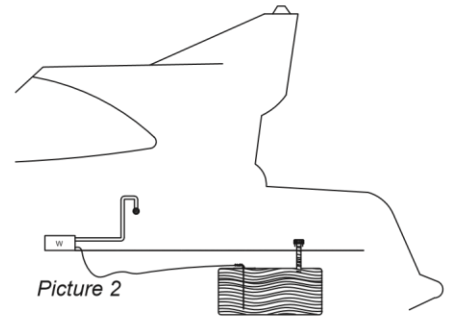

Picture 2

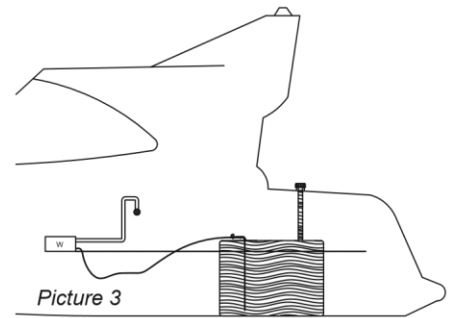

Picture 3



If the fuel level in the tank is above the device, a solenoid valve **30012** must be installed in the fuel line immediately after the tank lead-through.

Selecting the fuel

When selecting the fuel type, take note of the temperature limits of each particular fuel. The limit values provided here are to be treated as guidelines. Confirm the actual temperature limits from the fuel supplier.

- light furnace oil / diesel, summer grade, temperature must not fall below -5 °C.
- light furnace oil / diesel, winter grade, temperature must not fall below -24 °C.
- light furnace oil / diesel, arctic winter grade, temperature must not fall below -40 °C.

If the temperature drops lower than the minimum level, paraffin may form in the fuel. This may result in the fuel filter and pump being clogged. The clog will dissolve only if the fuel temperature rises clearly over 0 °C.

The less aromatic substances the fuel contains, the less deposits will be formed. Normal furnace oils contain 35–40 % of aromatic substances. In city diesels and green furnace oils the concentration is 20 %.



Confirm the actual temperature limits for the fuel you are using from the fuel supplier.

FLUE GAS CONNECTIONS

Flue gas lead-throughs

Flue gas lead-throughs **2467**, and the closable model **2460** are suitable for this device.

All flue gas lead-throughs are stainless steel. The \varnothing 28/45 mm lead-throughs fit the flue gas pipe **2448**.

General instructions for flue gas connections

LOCATION

Air must always flow freely past the lead-through. Install the lead-through on a FUEL straight surface. Avoid corners or recessions where wind pressure can disturb the functioning of the device.

The minimum distance of the lead-through from the fuel tank's filler hole is 400 mm.

The minimum distance of the side lead-through from the surface of the water is 300 mm. Especially in sail boats it should be noted that the lead-through must never be submerged.

It is recommended to place the lead-through in the side as far back as possible or directly in the transom.

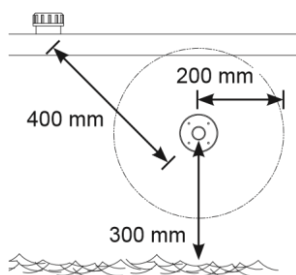

Safety distances

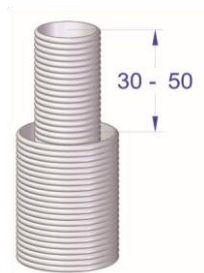

INSTALLATION

When preparing the installation cut-out for the lead-through, it is a good idea to use the lead-through as a model for the cut-out; especially if the lead-through is circular. If necessary, seal the installation cut-out with silicone in addition to the leadthrough seal. Note! Do not use silicone on a wooden boat.

The flue gas pipe must be 30–50 mm longer than the exhaust pipe. This way the flue gas pipe will stay in place in the lead-through more firmly. The measurement depends on the overall length of the piping.

The side lead-through must always be equipped with a so-called swan neck section.

The swan neck will effectively prevent splash water from getting to the device.

The highest point of the swan neck must always be above the surface of the water.

The stove will go out, if the flue gas lead through is submerged.

OTHER THINGS TO NOTE

Flue gas is hot. Always ensure that there is nothing that is susceptible to heat damage within 200 mm of the effective area of the flue gases (e.g. ropes, fenders or the side of another boat).

All lead-throughs raise the temperature of their surroundings. A wooden deck, in particular, may dry due to the heat. Remember that the surface of the lead-through is hot during use.

The flue gas pipe must be made of stainless steel **2448**.

If necessary, seal the connections between the flue gas pipe and the lead-through with heat-resistant silicone.

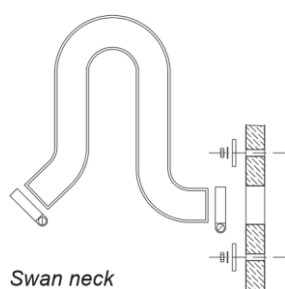

Swan neck



When washing the boat with a pressure washer, never aim the water jet at the lead-through as the device may get wet.

SPECIFIC INSTRUCTIONS FOR INDIVIDUAL LEAD-THROUGHS

2467 Side lead-through

A side lead-through is installed in the side of the boat or in the transom. In sail boats it is recommended to install it in the transom. The installation always requires a so-called swan neck piece.

Make the necessary installation cut-outs and spread a suitable sealing agent on both sides of the seal and on the screw holes. This will ensure that the connection is waterproof.

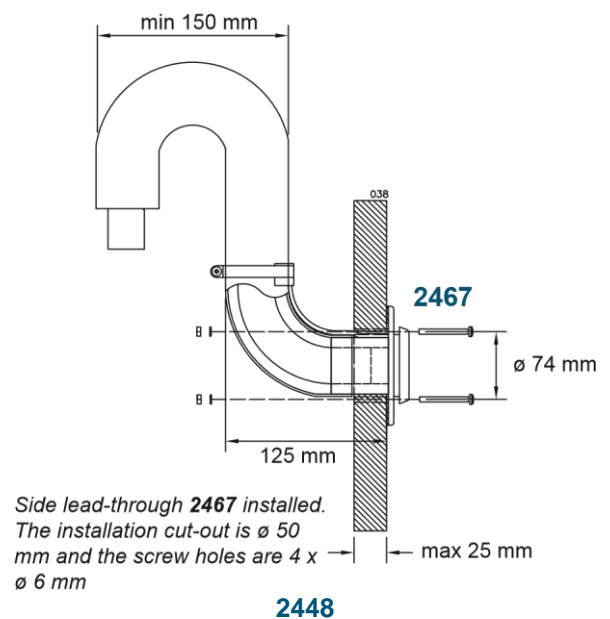
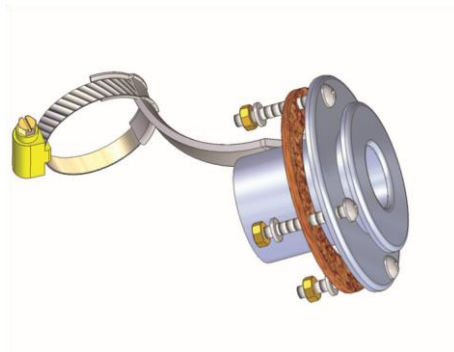

2460 Closable lead-through

The cap of the closable lead-through must be detached for installation and seal maintenance by pressing the spring indicated by the arrow in with, for instance, a screwdriver. Take care not to let the screwdriver slip as the spring is very stiff. Hold the cap with your other hand when pressing in the spring. When the spring is down, pull the cap gently out of the frame. When assembling the lead-through, ensure that the order of the parts is correct. Also make sure that the spring goes in the correct hole in the cap. Otherwise, the lead-through cannot be closed.

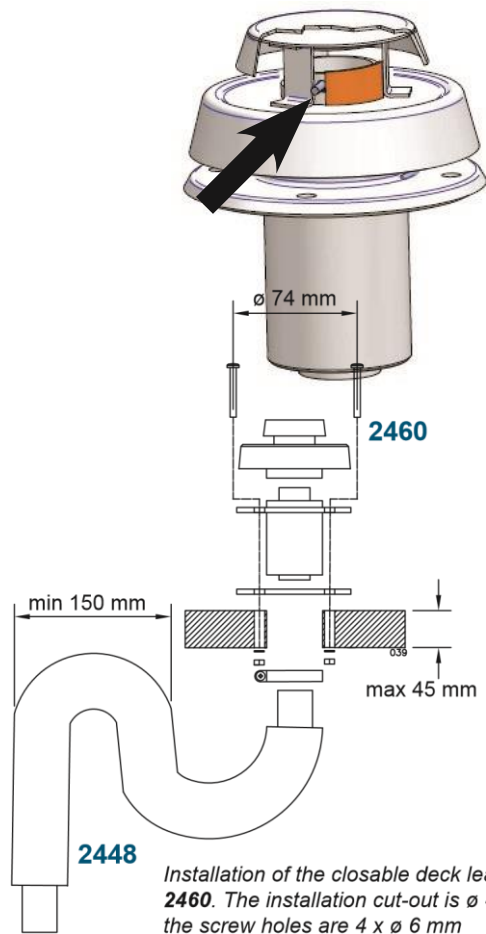

Installation of the closable deck lead-through **2460**. The installation cut-out is $\varnothing 45$ mm and the screw holes are 4 x $\varnothing 6$ mm

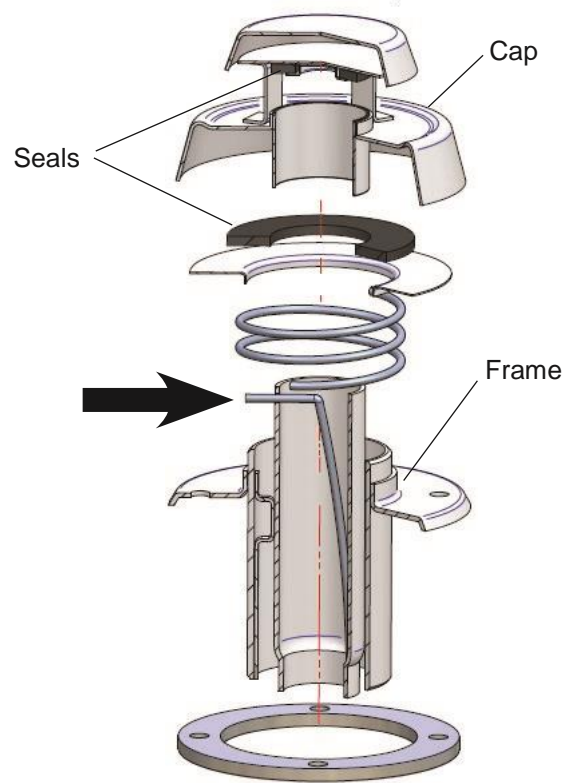

Closable deck lead-through **2460** and lead-through elevation **2069** for particularly demanding conditions.

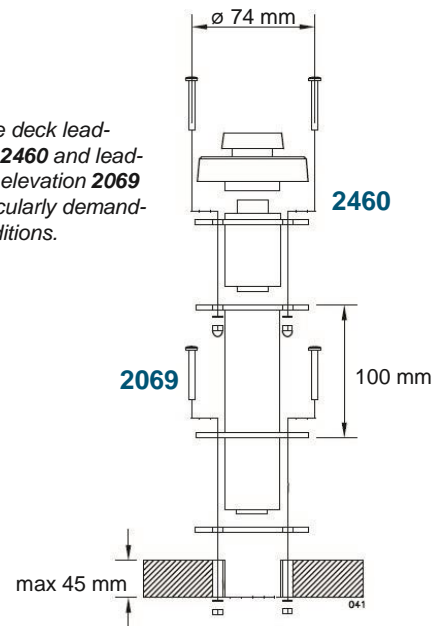

Insulation kit for a metal-hulled boat

An insulation kit must be used to insulate the lead-through from the boat's metal hull.

The insulation kit insulates the flue gas lead-through and the device from each other.

In fault situations the electric circuit runs between the metal hull and the device. This can result in the oxidation or malfunctioning of the device's circuit board, and, in the worst case scenario, the circuit board may be damaged.

Insulation kit 2461 for circular coaxial lead-throughs (2467 and 2460)

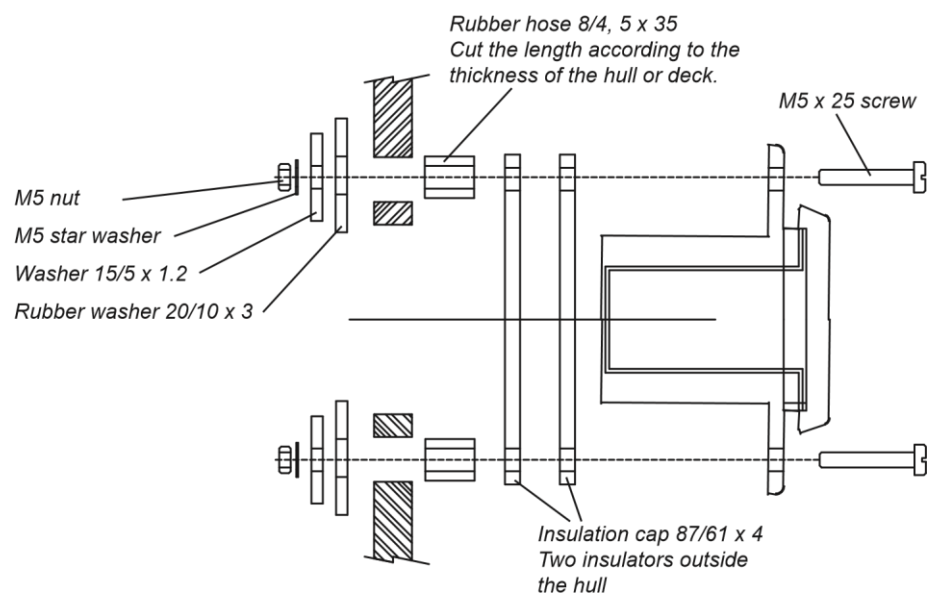

Use of the stove

The stove starts to heat up automatically when the power switch is turned to the ON position. The yellow current indicator LED will light as soon as the electricity is switched on. The red combustion indicator LED will be lit, when the burner flame has been lit and the burning has stabilised after roughly 2.5 – 4 min after the stove has been turned on.

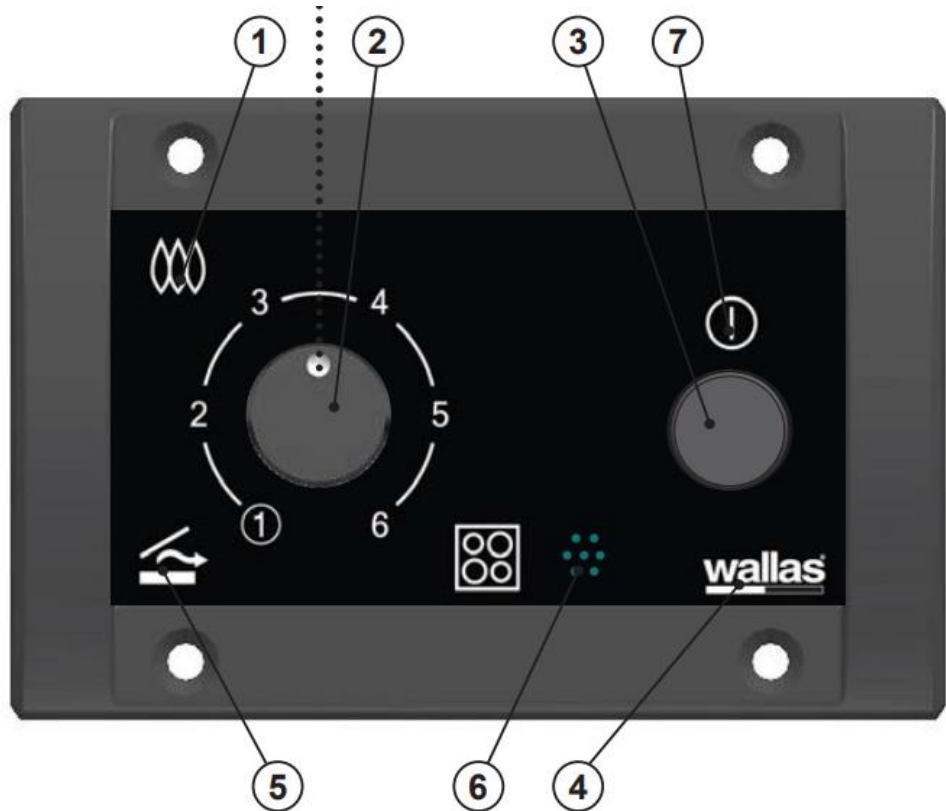

- | | |
|---|-------------------------|
| 1. Combustion indicator | 5. Thermostat indicator |
| 2. Temperature adjustment / Power control | 6. Thermostat sensor |
| 3. Heating switch | 7. Heating indicator |
| 4. Power indicator | |



After the stove has been started up, the power can be adjusted steplessly with the power adjustment knob. Avoid turning the adjustment knob back and forth rapidly, as this can cause the burner to become sooty.

To switch off the oven, turn the power switch to the OFF position. The yellow current LED will go out immediately. The red combustion LED will keep blinking for ca. five minutes while the device is cooling down. You cannot restart the stove until the combustion LED has stopped blinking.

The orange indicator light at the lower edge of the stove top will light when the stove is switched on.

After the stove is switched off, a timer will keep the light lit for roughly 50 minutes.

The orange indicator light will warn you of a hot cooking plate.

Colour	Blink interval	Function
Yellow		Power on
Red		Combustion indicator when the combustion has begun normally
Red		Aftercooling

FIRST START-UP



After installation or maintenance, if the fuel line is empty, the stove will not necessarily start up on the first try. If this is the case, the red combustion LED will begin to blink roughly 4.5 minutes after start-up.

Turn the power switch to the OFF position. The stove cannot be restarted until the cooling phase is complete.

When the cooling is finished, switch the stove on again.

If the stove does not start after two tries, it cannot be started again: the stove will lock down (lights blink to indicate this).

Release the lock (instructions in the maintenance section)

Depending on the length of the fuel hose, the device may have to be started up several times. Keep an eye on how the fuel travels in the fuel hose while starting up the stove.

ACCESSORIES

Toasting grill 1150

The toasting grill is a handy accessory for toasting bread for breakfast while making tea on the other cooking plate.

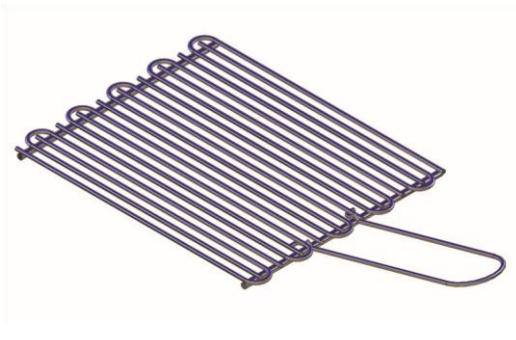

Kettle holder set 1012

Kettle holders keep cooking vessels in place on the stove when the boat tilts.



Intake connection set 3430

In demanding conditions, the intake connection set **3430** must be installed on the stove. The set prevents the stove from overheating.

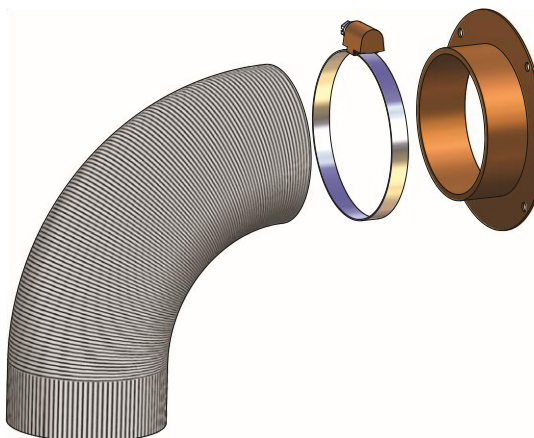

Things to note about the use of the cooking plate

Only use dishes with a smooth bottom so as to not damage the stove top. If you use the cold stove top for other work or chores, be sure to wipe it clean thoroughly after you are done. Even a small crumb, if hard enough, can scratch the surface when a kettle is placed on the stove top. These small scratches, which are to some extent inevitable, will in no way affect the heating power of the stove. The bottom of the cooking vessel should be slightly concave when cold so that when it expands due to the heat, it will sit evenly on the stove top and the heat energy will be distributed optimally.

The ideal bottom thickness for steel enamel vessels is 2–3 mm and for steel kettles with a sandwich bottom 4–6 mm.

Cleaning and maintaining the stove top

In order to keep the stove top in good condition both aesthetically and performance-wise, it should be cleaned regularly; preferably after each time of use. First scrape of the clearly noticeable dirt and food scraps with a cleaning spatula. Put a few drops of a cleaning agent for ceramic surfaces on the stove top and wipe it with a piece of kitchen paper. Then wipe the stove top with a moist cloth and dry it with another cloth. Do not use abrasive cleaning sponges or agents. Additionally, avoid using chemically strong cleaning agents, such as an oven cleaning spray or stain remover.

Immediately clean off aluminum foil, plastic, sugar or other sugary substances that have melted on the stove top. This prevents the surface from getting damaged.







Before cooking particularly sugary foods, the surface should be treated with a protective agent. This prevents possible damage due to the food boiling over.

Observe the general maintenance recommendations for Wallas equipment when servicing the electronic and mechanical parts of the stove.

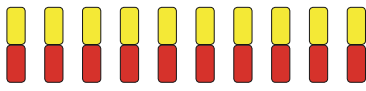

Never keep the stove on without a kettle.

Fault signals and releasing the lock

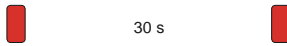
Colour	Blink interval	Fault description
Yellow	 2 s 2 s	Glow failure
Yellow	 2 s 2 s	Combustion air blower fault
Yellow	 2 s 2 s	Cooling blower fault
Yellow	 2 s 2 s	Undervoltage
Yellow Red	 2 s 2 s	Locking; the device locks itself after 2 unsuccessful starts *)
Red	 2 s 2 s	Overheat
Red	 30 s 30 s	5 minutes after fault indication



If the device has locked itself, you must determine the cause for the locking before releasing it.



***) RELEASING THE LOCK:**

1. Leave the operating switch of the device in the ON position (lights blink to indicate lockdown).
2. Detach the power cord (2) from the device and remove the fuse (13) which is in the power cord.
3. Reconnect the power cord and reinstall the fuse (yellow LED will be lit for 1–3 seconds).
4. When the yellow LED goes out, turn the operating switch to the OFF position.
5. You can now restart the device.

MAINTENANCE RECOMMENDATIONS

Basic maintenance of diesel-operated devices:

Maintenance measure	Maintenance interval	Carried out by
First inspection of basic functions	Inspection after first 500 hours of use or the first season of use	Authorised Wallas service shop
Cleaning the burner	The service shop recommends a suitable maintenance interval after performing the inspection of basic functions.	Authorised Wallas service shop

Winter storage

If the device uses the same tank as the engine:

Change the fuel filter. Perform measures recommended by the boat/engine manufacturer to be performed before winter storage.

If the device has a separate tank: Drain the fuel tank in the autumn. Clean the tank and change the fuel filter. Fill the fuel tank with fresh and clean fuel in the spring.

Special recommendations

If the device uses the same tank as the engine:

Observe the engine manufacturer's recommendation with regard to the fuel type and moisture removal. Only diesel or light furnace oil can be used in Wallas diesel-operated products.

If the device has a separate tank:

When selecting the fuel type, take note of the temperature limits of each particular fuel. Only diesel or light furnace oil can be used in Wallas diesel-operated products. During the season of use, isopropyl alcohol-based anti-freezing agent for petrol vehicles is added to the fuel to absorb the water in the fuel. For the dosage, observe the recommendations given by the manufacturer of the agent.

Opening the cooling case for maintenance measures

Various maintenance measures or inspection require you to open the cooling case. For minor work only the front hatch needs to be opened, but more extensive maintenance requires the removal of the entire cooling case.

If the device has been installed so as to leave sufficient space in front of the stove or if the fixture in which the stove has been installed has a detachable panel, the maintenance measures carried out by opening the front hatch do not require you to remove the entire device. Picture 1.



An anti-freezing agent for diesel vehicles may increase the forming of scale at the bottom of the burner and therefore shorten the maintenance interval.

To perform maintenance work on the stove, disconnect the flue gas pipe, the exhaust pipe and the power cord from the stove. Then, detach the stove from the table board and turn it upside down on the table. Place some padding on the table board to protect the ceramic surface. Open the screws in the front panel, open the cooling case screws and lift off the case. Pictures 2 - 5.

If you deliver the stove for maintenance, also disconnect the fuel hose and the control panel cable.

It is advisable to block the end of the fuel hose or otherwise ensure that no impurities enter the hose or that no fuel leaks into the boat during the maintenance. Deliver the stove for maintenance with the cooling case in place.

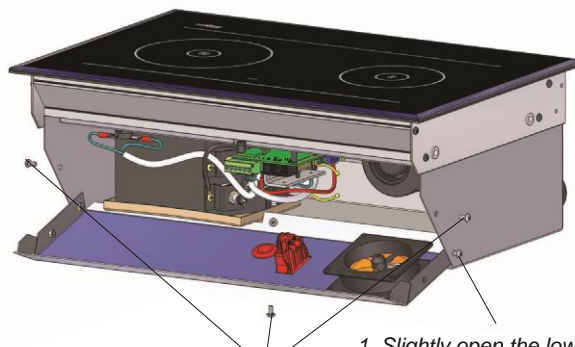

Picture 1

1. Slightly open the lower screws on the sides
2. Remove the upper three screws on the sides and one screw from the base.

3. The cover can be opened

3. The cover can be opened

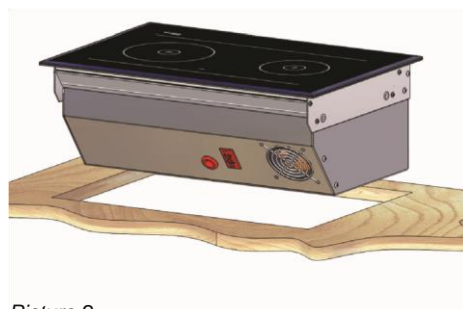

Picture 2

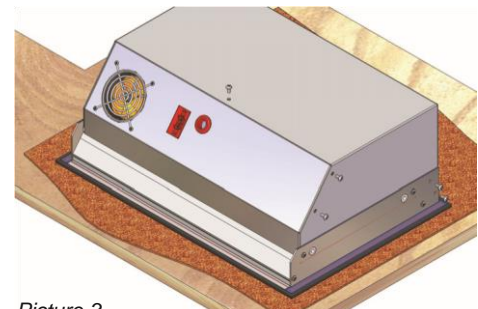

Picture 3

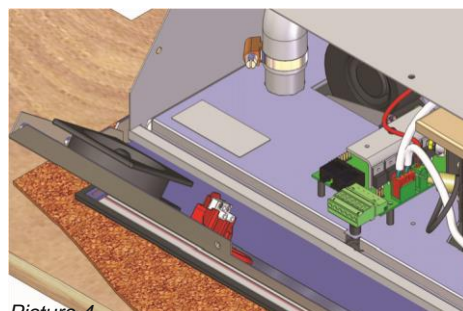

Picture 4

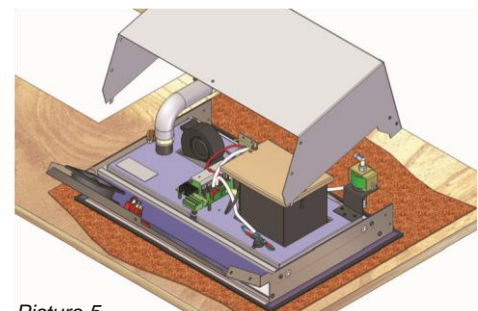

Picture 5

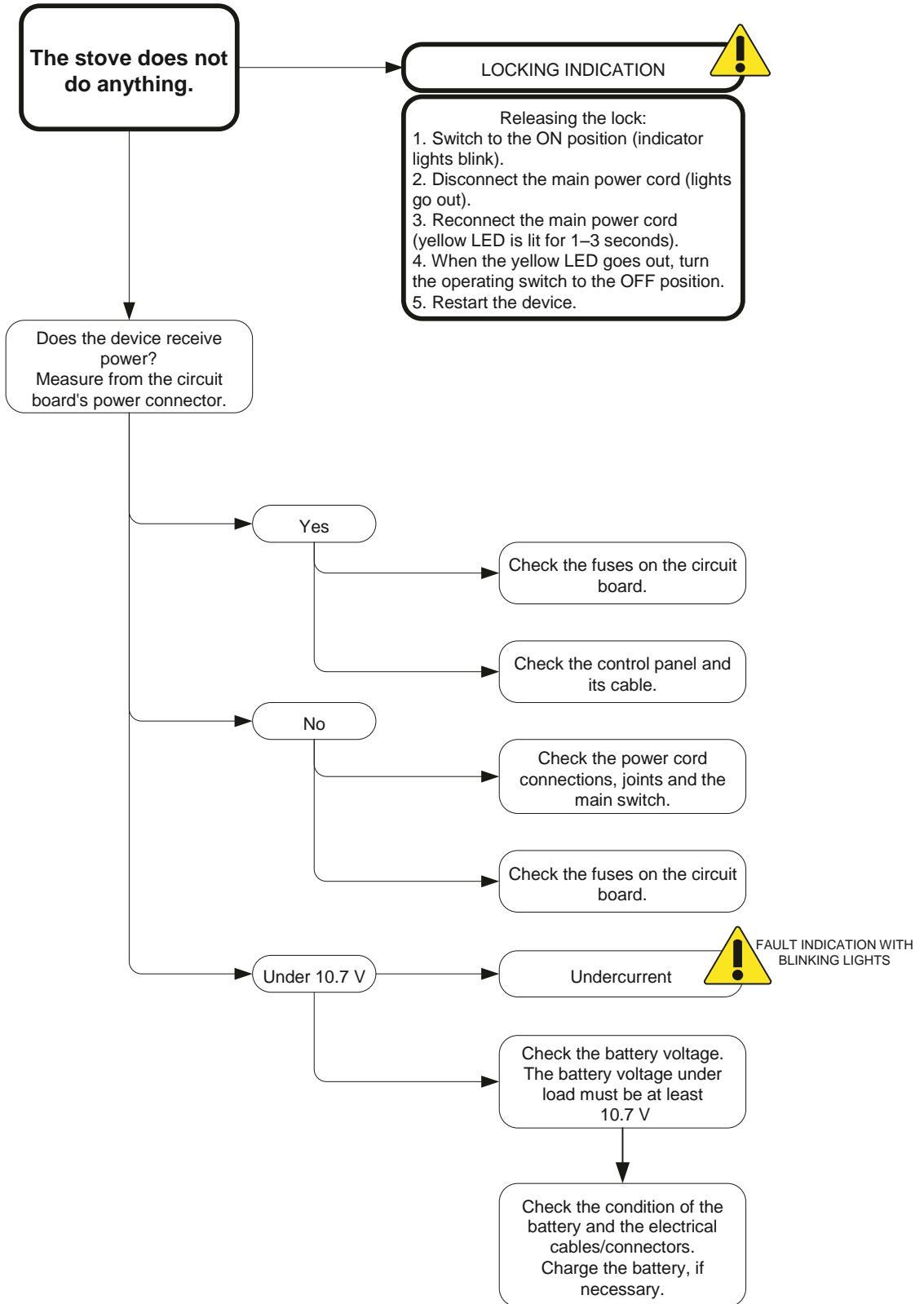

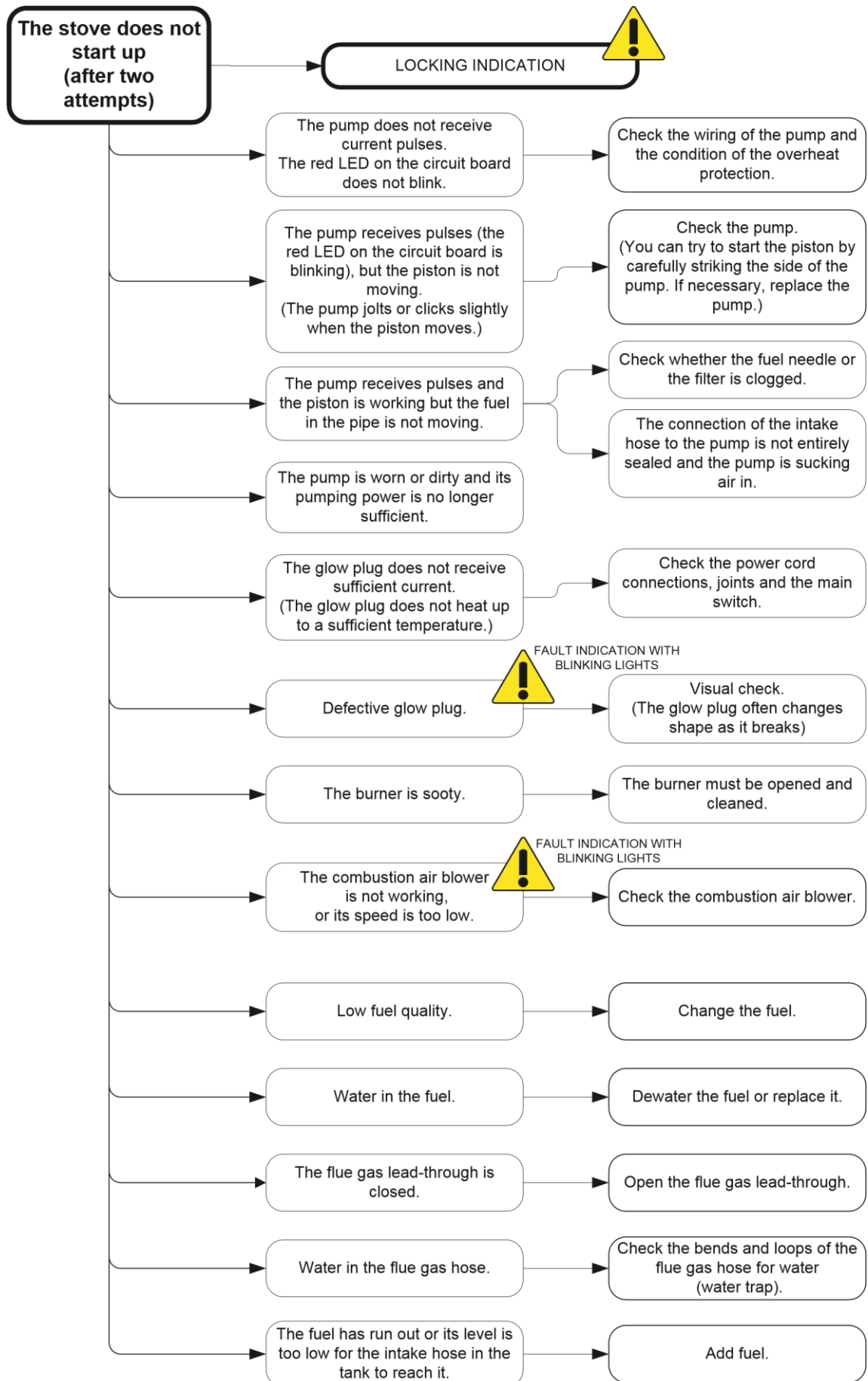

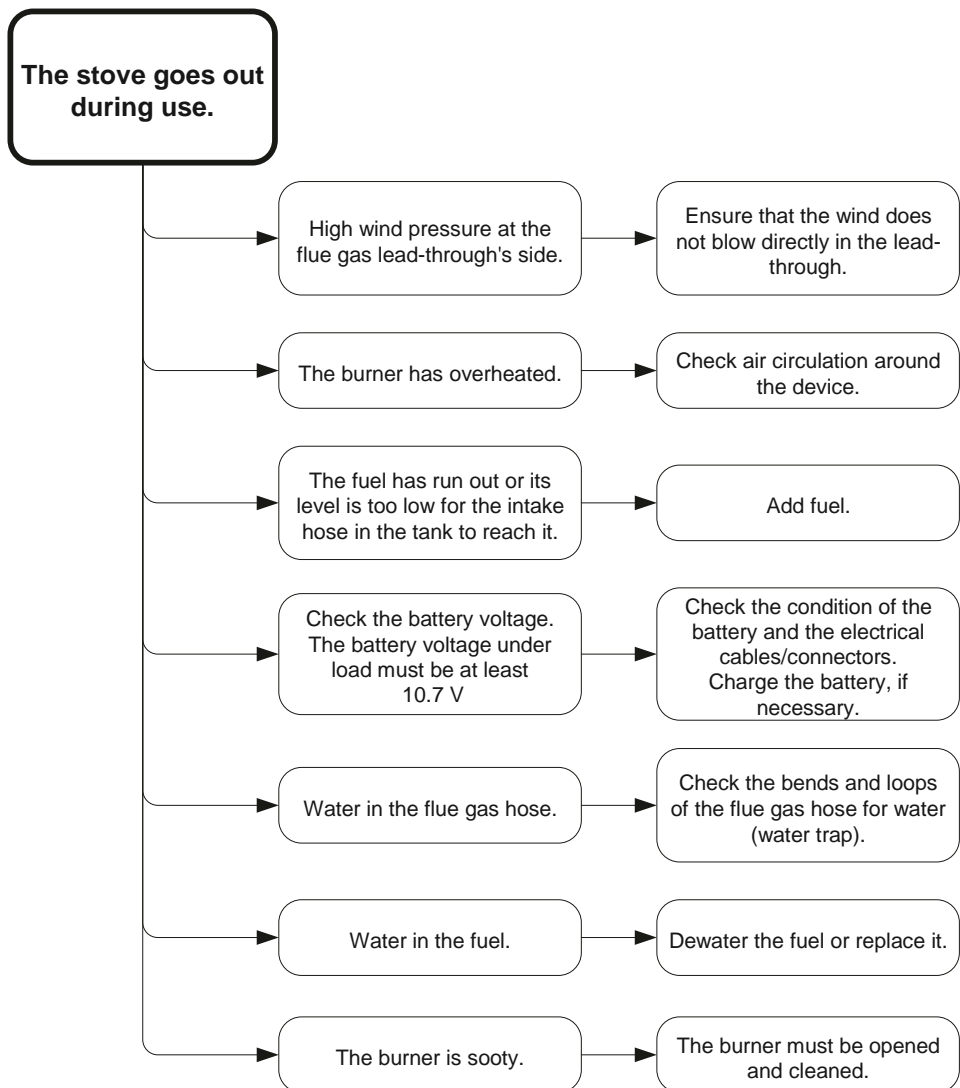
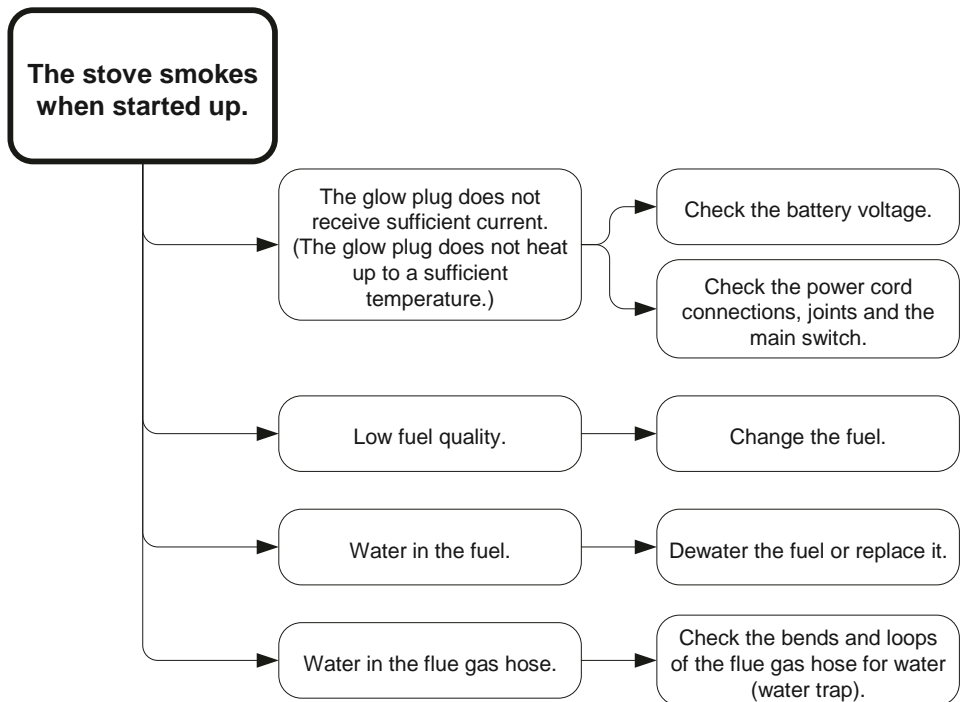

GENERAL GUARANTEE TERMS

Wallas-Marin Oy (the manufacturer) shall be liable for eventual defects in the raw material or manufacture of the products and items sold by the importer for 12 months from the day of sale on the following conditions.

1. Measures to take in the event of a defect:

- a) Look on the check list on the website (www.wallas.com) to make sure the defect in question is not related to use, i.e. a simple problem not covered by the warranty.
- b) Notification of the defect must be given in writing immediately if possible and no later than 2 months after the appearance of the defect. After the warranty period ends, a referral back to a notification at the time of the warranty period is not valid unless the notification was made in writing. A valid receipt or an other reliable official document of the time of purchase is required for the warranty.
- c) For repairs under warranty, the customer takes the product to the place of purchase (the seller is responsible for warranty issues) or to an authorized repair shop. Warranty service is not to take place outdoors or on a boat. The warranty does not cover costs for the removal and securing of the device or for damage caused by the incorrect packing of a device that has been sent for repair. d) The customer must provide the following information in writing for warranty service:
 - Description of the problem
 - A description of where and how the device was installed
 - Product type and serial number

2. The warranty is not valid in the following cases when:

- components which are not approved by the manufacturer have been added to the device and/or if its structure has been modified without the consent of the manufacturer.
- the instructions for installation, operation or maintenance have not been followed.
- storage or transport has been inappropriate.
- a problem has resulted from an accident or damage, which Wallas has had no control over (force majeure).
- problems arise from normal wear and tear. The fan motors of the heaters (and ventilation hood assembly 85D+270) have a natural wear limit of 1500 hours. Exceeding this limit within the warranty period means the customer is no longer entitled to replace the motors under warranty.
- the product has suffered from improper handling, unsuitable fuel, low voltage, excess voltage, damage due to dirt or water.
- the device has been opened without the explicit permission of the importer
- components other than Wallas' spare part components have been used in the repair of the device.

3. Repairs carried out during the warranty period do not renew or alter the original warranty period.

4. Indirect damages arising from a defective product are not covered by this warranty.

5. The warranty is only valid for boat products that have been installed in boats and for cottage products that have been installed in cottages. The warranty does not cover installation in vehicles or other areas.

6. To enable us to offer a high standard of service, the seller must keep a buyer register to inform buyers, if necessary, of eventual matters concerning the warranty period or technical information, modifications or the updating of the device after the warranty period has expired.

7. This warranty does not limit rights written down in the consumer protection laws.



When making a warranty claim, the customer must provide proof that the maintenance and safety instructions have been thoroughly followed. This warranty does not apply to defects which have arisen due to carelessness in following installation, operation and maintenance instructions.

Handwriting practice area consisting of 20 horizontal dotted lines.

88DU

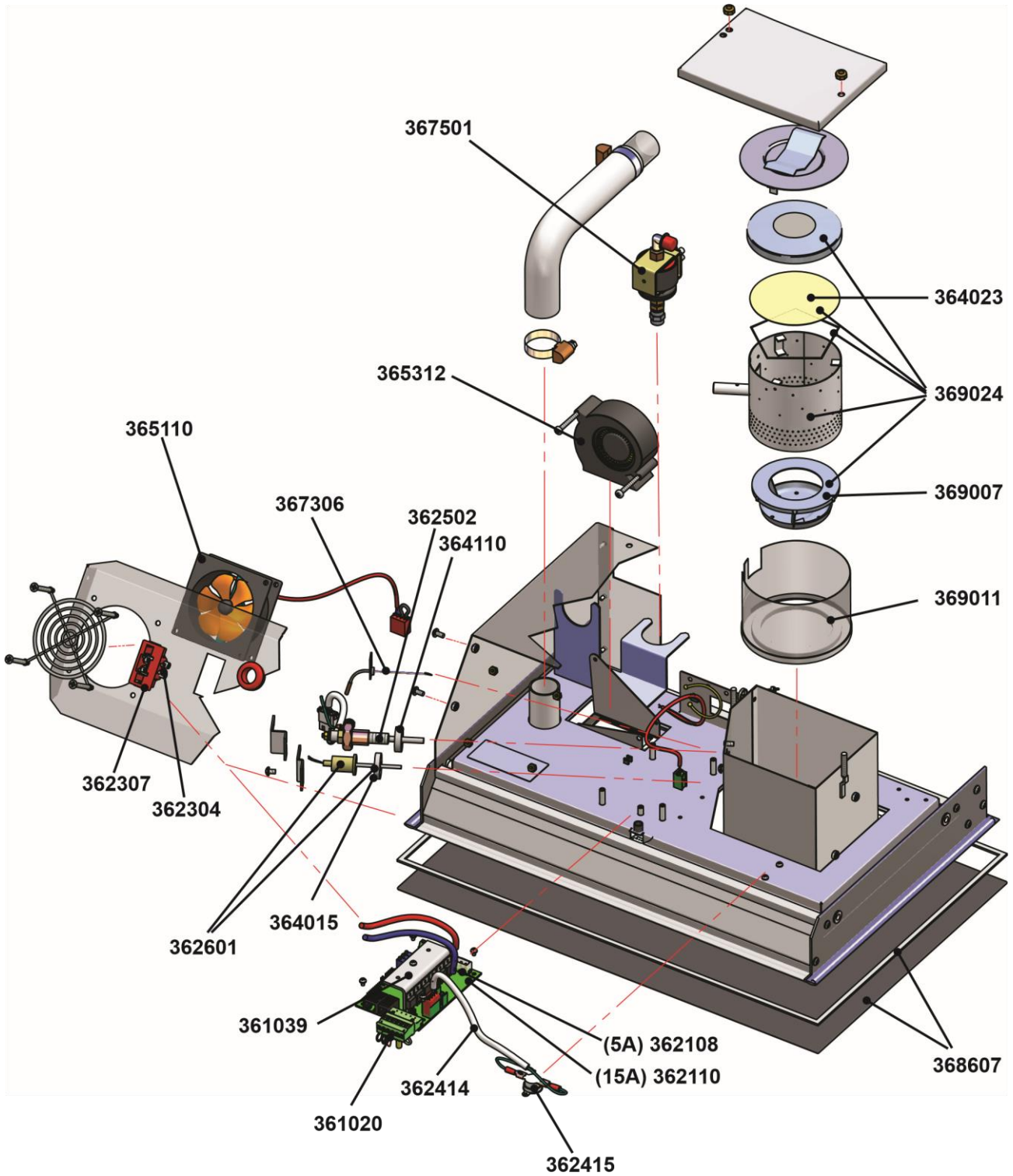

Wallas-Marin Oy
Kärrykatu 4
20780 Kaarina Finland www.wallas.com

We reserve the right to changes.

490070AGB
