

Orbital Sander
OBS-18DC HDTR
Operator's Manual



READ THIS BOOK

This book has important information for the use and safe operation of this machine. Failure to read this book prior to operating or attempting any service or maintenance procedure to your American Sanders machine could result in injury to you or to other personnel; damage to the machine or to other property could occur as well. You must have training in the operation of this machine before using it. If your operator(s) cannot read this manual, have it explained fully before attempting to operate this machine.

All directions given in this book are as seen from the operator's position at the rear of the machine.

Section A - Contents

Operator Safety Instructions.....	2
General Power Tool Safety Warnings.....	3
Introduction.....	6
Machine Specifications.....	6
Machine Transportation.....	6
Machine Setup.....	7
Safety Instructions.....	7
Dust Collection.....	8
Operating Instructions.....	9
Sanding Cuts & Sandpaper.....	9
Troubleshooting.....	10

Section D - Parts Manual

Notes.....	26
Electrical Schematic.....	27
Base Assembly.....	28
Motor Assembly.....	30
Handle Assembly.....	32

WARNING!

The Products sold with this Manual contain or may contain chemicals that are known to certain governments (such as the State of California, as identified in its Proposition 65 Regulatory Warning Law) to cause cancer, birth defects or other reproductive harm. In certain locations (including the State of California) purchasers of these Products that place them in service at an employment job site or a publicly accessible space are required by regulation to make certain notices, warnings or disclosures regarding the chemicals that are or may be contained in the Products at or about such work sites. It is the purchaser's responsibility to know the content of, and to comply with, any laws and regulations relating to the use of these Products in such environments. The Manufacturer disclaims any responsibility to advise purchasers of any specific requirements that may be applicable to the use of the Products in such environments.

*****This product is intended for commercial use only*****













Operator Safety Instructions

In this Operation Manual you will find three statements that you must read and observe to ensure safe operation of this machine.

DANGER means: Severe bodily injury or death can occur to you or other personnel if the **DANGER** statements found on this machine or in this Operation Manual are ignored or are not adhered to. Read and observe all **DANGER** statements found in this Operation Manual and on your machine.

WARNING means: Injury can occur to you or to other personnel if the **WARNING** statements found on your machine or in the Operation Manual are ignored or are not adhered to. Read and observe all **WARNING** statements found in this Operation Manual and on your machine.

CAUTION means: Damage can occur to the machine or to other property if the **CAUTION** statements found on your machine or in this Operation Manual are ignored or are not adhered to. Read and observe all **CAUTION** statements found in this Operation Manual and on your machine.

-  **DANGER:** Failure to read the Owner's Manual prior to operating or servicing your American Sanders machine could result in injury to you or to other personnel; damage to the machine or to other property could occur as well. You must have training in the operation of this machine before using it. If you or your operator(s) cannot read English, have this manual explained fully before attempting to operate this machine.
-  **DANGER:**  A. Sanding/finishing wood floors can create an explosive or combustible environment. Do not operate this machine around solvents, thinners, alcohol, fuels, floor finishes, wood dust or any other flammable materials. Cigarette lighters, pilot lights, electrical sparks and all other sources of ignition should be extinguished or avoided. Keep work area well ventilated.
B. Dust generated from sanding wood floors can spontaneously ignite or explode. Promptly dispose of any sanding dust in a metal container clear of any combustibles. Do not dispose in a fire.
-  **DANGER:**  A. Electrocutation could occur if the machine is being serviced while the machine is connected to a power source. Disconnect the power supply before servicing.
B. Electrocutation or fire could occur if the machine is being operated with a damaged power cord. Keep the power cord clear of the pad. Always lift the cord over the machine. Do not move the machine by the power cord.
C. Shock hazard. Do not use the machine if it has been rained on or sprayed with water.
-  **DANGER:**  To avoid injury keep hands, feet, and loose clothing away from all moving parts on the machine. Disconnect the power cord before replacing the pad, changing the abrasive, or when servicing. Do not operate the machine unless all guards are in place. Never leave the machine unattended while connected to a power source.
-  **WARNING:**  Injury can occur if protective clothing or equipment is not used while sanding. Always wear safety goggles, protective clothing, and dust mask while sanding.
-  **WARNING:**  This sander is not to be used on pressure treated wood. Some pressure treated woods contain arsenic and sanding pressure treated wood produces hazardous dust. Inhaling hazardous dust from pressure treated wood can cause serious injury or death. Sanding pressure treated wood decks or uneven surfaces can damage the sander which is not covered under warranty or damage waiver.
-  **WARNING:** Any alterations or modifications of this machine could result in damage to the machine or injury to the operator or other bystanders. Alterations or modifications not authorized by the manufacturer voids any and all warranties and liabilities.
-  **WARNING:** Risk of explosion. Floor sanding can result in an explosive mixture of fine dust and air. Use floor sanding machine only in a well-ventilated area free from any flame or match.

General Power Tool Safety Warnings

WARNING: Read all safety warnings and instructions. Failure to follow warnings and instructions may result in electric shock, fire and or serious injury.

Save all warnings and instructions for future use.

The term "power tool" in the warnings refers to your main-operated (corded) power tool or battery operated (cordless) power tool.

1) Work area safety

- Keep work area clean and well lit.** Clutter or dark areas invite accidents.
- Do not operate power tools in explosive atmospheres, such as in the presence of flammable liquids, gasses, or dust.** Power tools create sparks which may ignite the dust or fumes.
- Keep children and bystanders away while operating a power tool.** Distractions can cause you to lose control.

2) Electrical safety

- Power tool plugs must match the outlet. Never modify the plug in any way. Do not use any adapter plugs with earthed (grounded) power tools.** Unmodified plugs and matching outlets will reduce risk of electric shock.
- Avoid body contact with earthed or grounded surfaces such as pipes, radiators, ranges, and refrigerators.** There is an increased risk of electric shock if your body is earthed or grounded.
- Do not expose power tools to rain or wet conditions.** Water entering a power tool will increase the risk of electric shock.
- Do not abuse the cord. Never use the cord for carrying, pulling or unplugging the power tool. Keep cord away from heat, oil, sharp edges or moving parts.** Damaged or entangled cords increase the risk of electric shock.
- When operating a power tool outdoors, use an extension cord suitable for outdoor use.** Use of cord suitable for outdoor use reduces the risk of electric shock.

- f) **If operating a power tool in a damp location is unavoidable, use a residual current device (RCD) or ground fault circuit interrupter (GFCI) protected supply.** Use of a RCD or GFCI reduces the risk of electric shock.

3) Personal safety

- a) **Stay alert, watch what you are doing and use common sense when operating a power tool. Do not use a power tool while you are tired or under the influence of drugs, alcohol, or medication.** A moment of inattention while operating power tools may result in serious personal injury.
- b) **Use personal protective equipment. Always wear eye protection.** Protective equipment such as dust mask, non-skid safety shoes, hard hat, or hearing protection used for appropriate conditions will reduce personal injury.
- c) **Prevent unintentional starting. Ensure switch is in off-position before connecting to power source and/or battery pack, picking up, or carrying the tool.** Carrying power tools with your finger on the switch or energizing power tools that have the switch on invites accidents.
- d) **Remove any adjustment wrench or key before turning the power tool on.** A wrench or key left attached to a rotating part of the power tool may result in personal injury.
- e) **Do not overreach. Keep proper footing and balance at all times.** This enables better control of the power tool in unexpected situations.
- f) **Dress properly. Do not wear loose clothing or jewelry. Keep your hair, clothing and gloves away from moving parts.** Loose clothes, jewelry, or long hair can be caught in moving parts.
- g) **If devices are provided for the connection of dust extraction and collection facilities, ensure these are connected and properly used.** Use of dust collection can reduce dust related hazards. It is recommendation that the tool always be supplied via a residual current device with a rated residual current of 30mA or less.

4) Power tool use and care

- a) **Do not force the power tool. Use the correct power tool for your application.** The correct power tool will do the job better and safer at the rate for which it was designed.
- b) **Do not use the power tool if the switch does not turn it on and off.** Any power tool that cannot be controlled with the switch is dangerous and must be repaired.
- c) **Disconnect the plug from the power source and/or the battery pack from the power tool before making any adjustments, changing accessories or storing power tools.** Such preventative safety measures reduce the risk of starting the power tool accidentally.
- d) **Store idle power tools out of the reach of children and do not allow persons unfamiliar with the power tool or these instructions to operate the power tool.** Power tools are dangerous in the hands of untrained users.
- e) **Maintain power tools. Check for misalignment or binding of moving parts, breakage of parts and any other condition that may affect the power tool's operation. If damaged, have the power tool repaired before use.** Many accidents are caused by poorly maintained power tools.
- f) **Keep cutting tools sharp and clean.** Properly maintained cutting tools with sharp cutting edges are less likely to bind and are easier to control.
- g) **Use the power tool, accessories and tool bits ect. in accordance with these instructions, taking into account the working conditions and the work to be performed.** Use of the power tool for operations different from those intended could result in a hazardous situation.

5) Service

- a) **Have the power tool serviced by a qualified repair person using only identical replacement parts.** This will ensure that the safety of the power tool is maintained. If the supply cord is damaged, it must be replaced by the manufacturer, its service agent or similarly qualified persons in order to avoid a hazard.

Safety Warnings For Sanding Operations

1. This power tool is intended to function as a sander. Read all safety warnings, instructions and specifications provided with this power tool. Failure to follow all instructions listed below may result in electric shock, fire, or personal injury.
2. Operations such as grinding, wire brushing, polishing or cutting-off, are not recommended to be performed with this power tool. Operations for which the tool was not designed may create a hazard and cause personal injury.
3. Do not use accessories which are not specifically designed and recommended by the tool manufacturer. Just because the accessory can be attached to your power tool, it does not assure safe operation.
4. The rated speed of the accessory must be at least equal to the maximum speed marked on the power tool. Accessories running faster than their rated speed can break and fly apart.
5. The outside diameter and thickness of your accessory must be within the capacity rating of your power tool. Incorrectly sized accessories cannot be adequately guard or controlled.
6. The arbor size of wheels, flanges, backing pads or any other accessory must fit the spindle of the power tool. Accessories with arbor holes that do not match the mounting hardware of the power tool will run out of balance, vibrate excessively and may cause loss of control.
7. Do not use damaged accessory. Before each use inspect the accessory such as abrasive wheel for chips or cracks, backing pad for cracks, tear or excess wear, wire brush for loose or cracked wires. If power tool or accessory is dropped, inspect for damage or install an undamaged accessory. After inspecting or installing an accessory, position yourself or bystanders away from the plane of the rotating accessory and run the power tool at maximum no-load speed for one minute. Damaged accessories will normally break apart during this time.

8. Wear personal protective equipment. Depending on application, use face shield, safety goggles or safety glasses. As appropriate, wear dust mask, hearing protectors, gloves and workshop apron capable of stopping flying debris generated by various operations. The eye protection must be capable of stopping flying debris generated by various operations. The dust mask or respirator must be capable of filtering particles generated by your operations. Prolonged exposure to high intensity noise may cause hearing loss.
9. Keep bystanders a safe distance away from work area. Anyone entering the work area must wear personal protective equipment. Fragments of work piece or a broken accessory may fly away and cause injury beyond immediate area of operation.
10. Hold power tool by gripping insulated surfaces (handle) only, when performing an operation where the cutting accessory may contact hidden wiring or its own cord. Cutting accessory contacting a "live" wire may make exposed metal parts of the power tool "live" and shock the operator.
11. Position the cord clear of the spinning accessory. If you lose control, the cord may be cut or snagged and your arm or hand may be pulled into the spinning accessory.
12. Never lay the power tool down until the accessory has come to a complete stop. The spinning accessory may grab the surface and pull the power tool out of your control.
13. Do not run the power tool while carrying it at your side. Accidental contact with the spinning accessory could snag your clothing, pulling the accessory into your body.
14. Regularly clean the power tools air vents. The motor's fan will draw the dust inside the housing and excessive accumulation may cause electrical hazards.
15. Do not operate the power tool near flammable materials. Sparks could ignite these materials.
16. Do not use excessively oversized sanding disc paper. Follow manufacturer's recommendations when selecting sanding paper. Larger sanding paper extending beyond the sanding pad presents a laceration hazard and may cause snagging, tearing of the disc or kickback.
17. Risk of explosion. Floor sanding can result in an explosive mixture of fine dust and air. Use floor sanding machine only in a well-ventilated area free from any flame or match.

Kickback and Related Warnings

Kickback is a sudden reaction to a pinched or snagged rotating wheel, backing pad, brush or any other accessory. Pinching or snagging causes rapid stalling of the rotating backing pad which in turn causes uncontrolled power tool to be forced in the opposite direction of the backing pad's rotation at the point of the binding.

For example, if an abrasive wheel is snagged or pinched by the work piece, the edge of the wheel that is entering into the pinch point can dig into the surface of the material causing the wheel to climb out or kick out. The wheel may either jump toward or away from the operator, depending on direction of the wheel's movement at the point of pinching. Abrasive wheels may also break under these conditions.

Kickback is the result of power tool misuse and incorrect operating procedures or conditions and can be avoided by taking proper precautions as given below.

1. Maintain a firm grip on the power tool and position your body and arms to allow you to resist kickback forces. Always use auxiliary handles, if provided for maximum control over kickback or torque reactions during start up. The operator can control torque reactions or kickback forces, if proper precautions are taken.
2. Never place your hand near the rotating accessory. Accessory may kickback over your hand.
3. Do not position your body in the area where power tool will move if kickback occurs. Kickback will propel the tool in the direction opposite to the wheel's movement at the point of the snagging.
4. Use special care when working corners, sharp edges etc. Avoid bouncing and snagging the accessory. Corners, sharp edges or bouncing have a tendency to snag the rotating accessory and cause loss of control or kickback.

Additional Rules For Safe Operation

1. Empty the dust bag or dust collection receiver frequently. Do not leave residue in dust bag or dust collection receiver unattended. Always empty in a non-combustible metal container. Sanding wood or varnish produces dust that can self ignite and cause injury or damage. Follow this precaution for storage.
2. Set all exposed nails. Sweep loose abrasive away from work area. Do not strike metal pipes, ect., with sanding paper. Striking metal or abrasive particles with sanding paper produces sparks that could ignite the sanding dust which can cause injury or damage.
3. Do not operate a partially assembled power tool. Keep all adjustments within manufacturer's specifications. Keep all fasteners tight. Operating a partially assembled power tool could result in injury to the operator or bystander and could cause damage to the equipment or surroundings.
4. Do not attempt to change the sanding paper while the power tool is running. The sanding pad can snag clothing and cause injury to limbs and moving sanding paper can cause abrasions.
5. The power tool should only be used on an electrical system (mains) that is rated for the electrical requirements of the power tool as shown on the nameplate. Use only on an earthing (grounded) system. Do not service the power tool if it is energized or connected to an electrical circuit. Improper use could cause fire or electric shock.

Introduction

The OBS-18 or OBS-18DC can be used on a variety of surfaces. It is an ideal tool for wood flooring maintenance and restoration work. It is also suitable for cleaning hard surfaces such as tile or Terrazzo.

Machine Specifications

Model	OBS-18DC
Model Number	07014A
Voltage / Frequency	115V / 60Hz
Amperage (A)	10
Motor	1 hp 750 Watts
Pad Size	12" X 18" (305mm X 457mm)
Power Cable	40ft 12-3 Ga Gray Rubber Jacketed
Orbits Per Minute	3600
Orbit Diameter	1/4" (6.4mm)
Shipping Weight	125 lbs (57 kg)
Noise (dBA)	74
Vibration (m/s/s)	11.2

Machine Transportation

To transport the machine, follow this procedure:

1. Unplug machine cord from the wall outlet and wrap the cord around the handle.
2. Raise and lock the handle in the upright position. To lock the handle, pull up on the Handle Release Compression Lever (see *Figure 1*).
3. Grasp the machine at the lift points (see *Figure 2*) and place in cargo area.

WARNING: The machine is heavy (125 lbs / 57 kg). To avoid injury or damage to the machine use a firm grip and proper lifting technique. Get assistance if necessary.

4. Secure machine to prevent movement in cargo area.

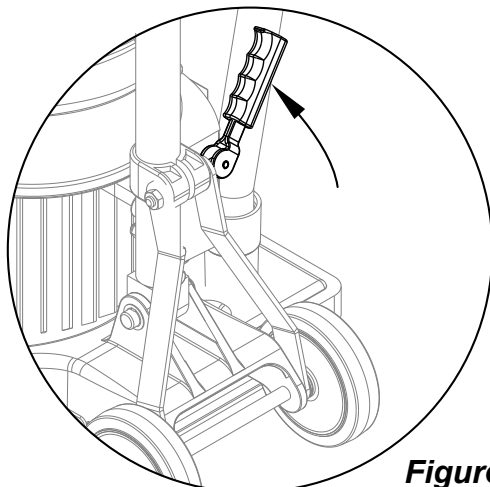
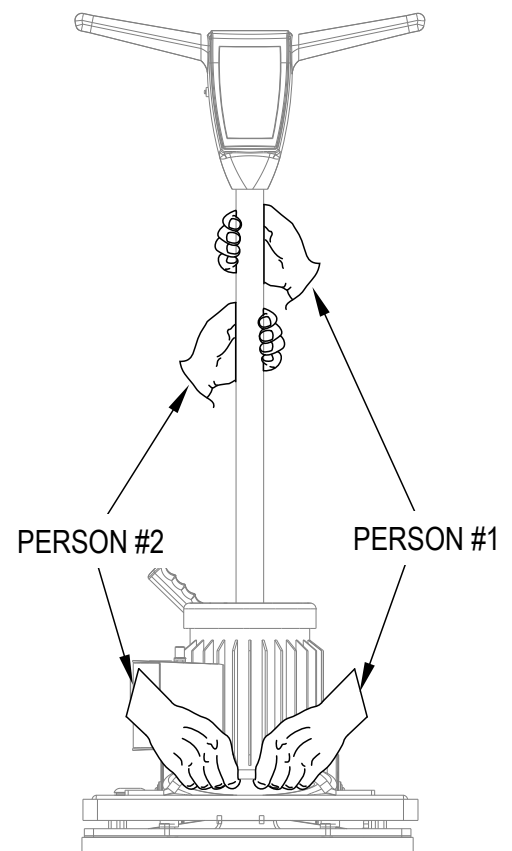

Figure 1

Figure 2





Machine Setup

To prepare the machine for use follow this procedure:

1. Familiarize yourself with the machine. Read all danger, warning, and caution statements and the Operation and Parts Manual before operating the machine. If you or the operator are unable to read English, have this manual fully explained before attempting to operate this machine.
2. Install or replace pad. The pad should be replaced if it has become matted down to a thickness of 3/8" (9,5 mm) or less. To install or replace the pad, follow these instructions:
 - A. Lock handle in the upright position.
 - B. Tilt the machine back until it fully rests on the handle.
 - C. Standing over the machine, remove existing pad then center new pad over grip face.
 - D. Press pad against grip face until the hooks in the driver have set in the pad (see *Figure 3*).
 - E. Return machine to the upright position.



Figure 3

-  **WARNING:** Never put yourself or let others be in a position to get injured if the machine should tip or fall, while replacing the pad or changing abrasive.
-  **CAUTION:** Damage to the grip face will occur if the machine is operated without a pad or with a pad that is 3/8" (9,5 mm) or thinner

Safety Instructions

This floor-finishing machine shall be grounded while in use to protect the operator from electrical shock. The machine is provided with a three-conductor cord and a three contact grounding attachment plug to fit the proper grounding type receptacle. The green (or green and yellow) conductor in the cord is the grounding wire. Never connect this wire to other than the grounding pin of the attachment plug.

This machine is for use on a nominal 120 volt circuit and has a grounding plug that resembles the plug illustrated as (A) in the sketch. Make sure that the machine is connected to an outlet having the same configuration as the plug. No adapter should be used with this machine.

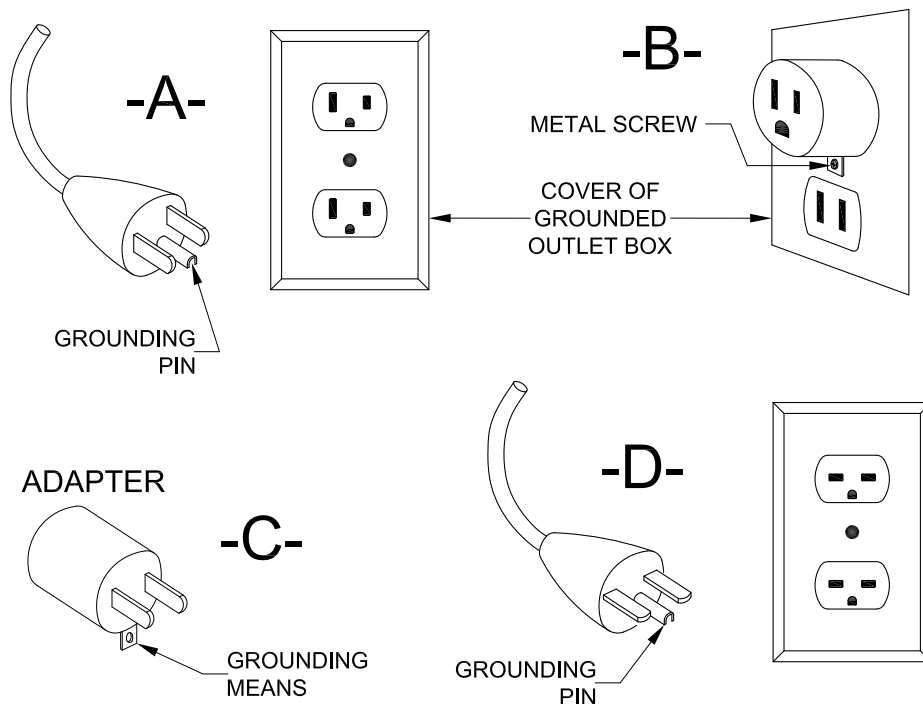

Dust Collection

This sanding machine is designed to be operated with a remote vacuum dust collection system or with the included dust bag

Preparing Remote Vacuum Dust Collection Systems

To prepare the machine for remote vacuum dust collection systems that have a 2" hose end, follow this procedure:

1. Install 2" hose end (*Figure 4 - A*) directly into the exhaust tube (*Figure 4 - B*).
2. The exhaust tube can be rotated for optimum convenience.

To prepare the machine for remote vacuum dust collection systems that have a 1-1/2" hose end, follow this procedure:

1. Install 2" hose end (*Figure 4 - A*) directly into the exhaust tube (*Figure 4 - B*).
2. The exhaust tube can be rotated for optimum convenience.

NOTE: Start the remote vacuum collections system before operation.

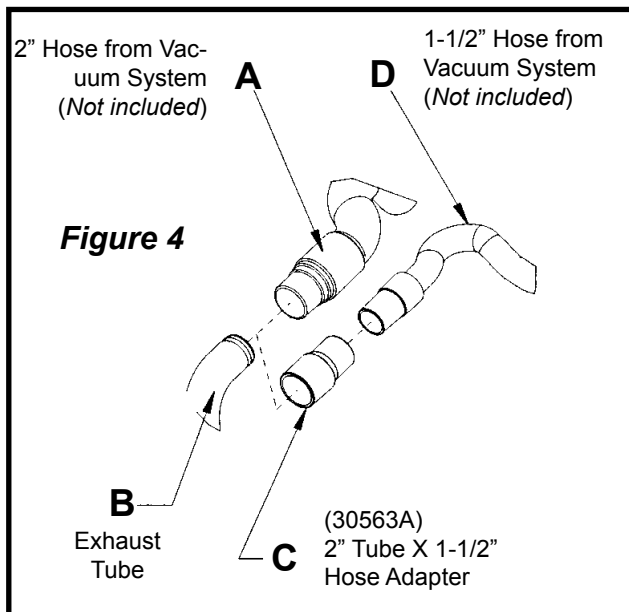

Preparing Using the Dust Bag

To prepare the machine for use with the included dust bag (Part No.53741A), follow this procedure:

1. Install the dust bag by pressing the end onto the exhaust tube until the ring locks into the groove (*Figure 5*). This is best done by pressing on the back of the bag opening with the palm of your hand.
2. The exhaust tube can be rotated for optimum convenience.
3. To remove the dust bag from the exhaust tube, pry up the end of the bag opening to partially release the internal rib from the groove, then pull.
4. To empty the dust bag, unzip the disposal flap and force contents out by inverting the bag.

NOTE: For best results, empty frequently. Follow all warnings posted in this manual and on the dust bag.

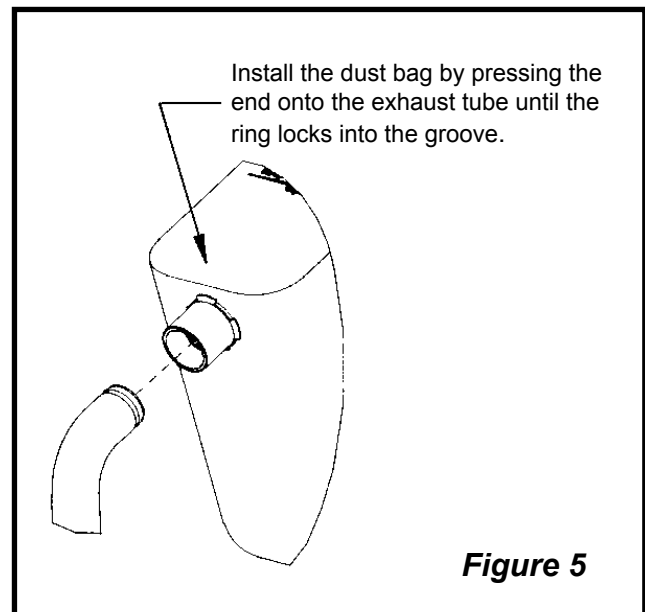

Operating Instructions - Sanding

To operate the machine as a sander follow this procedure:

1. Move machine to work location. Decide the best approach to sanding the desired area. When sanding the area, work so that you are moving away from the power supply. This will help to avoid entanglement with the power cord and reduce the need to move the power cord as frequently.
2. Install the abrasive (see *Sanding Cuts & Sandpaper*). Use the same procedure outlined in "MACHINE SETUP" for installing the pad, to install the abrasive. Peel the film off the back of the abrasive; center the abrasive over the pad and press it against the pad. The adhesive on the abrasive will hold it to the pad.

NOTE: When using screen abrasive, set the screen on the floor then move the machine over the screen. Lower the machine until the pad comes to rest on the screen. Make sure the screen is centered on the pad.

WARNING: Injury can occur if the machine is connected to a power source while installing the pad or abrasive. Disconnect the machine before installing the pad/abrasive.

3. Connect the machine to an appropriately fused and grounded circuit.
4. Release the handle by pressing up on the locking lever. Bring the handle to a comfortable position.

CAUTION: Do not lock the handle. Locking the handle will prevent the machine from resting evenly on the pad and diminish the machine performance and reliability.

5. Push the interlock button (1), and apply pressure to the levers (2). To stop the machine, release the levers (2) (see *Figure 6*).

CAUTION: To prevent damage to the flooring and to reduce swirling, keep the machine in motion while the motor is running.

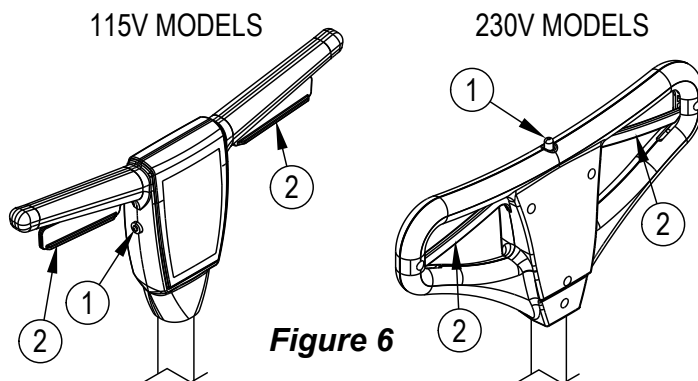

Operating Instructions - Polishing

To operate the machine as a polisher follow this procedure:

WARNING: Injury can occur if the machine is connected to a power source while installing the pad or abrasive. Disconnect the machine before installing the pad/abrasive.

1. Connect the machine to an appropriately fused and grounded circuit.
2. Release the handle by pressing up on the locking lever. Bring the handle to a comfortable position.

CAUTION: Do not lock the handle. Locking the handle will prevent the machine from resting evenly on the pad and diminish the machine performance and reliability.

3. Push the interlock button (1), and apply pressure to the levers (2). To stop the machine, release the levers (2) (see *Figure 6*).

CAUTION: To prevent damage to the flooring and to reduce swirling, keep the machine in motion while the motor is running.

Sanding Cuts & Sandpaper

Initial Cut:

The purpose of the initial cut is to remove old finish and gross imperfections on the floor surface. Use a course (20-36 grit) grain abrasive.

Final Cuts:

The purpose of a finishing cut is to remove the scratches produced during the initial cut. Use a fine (60-80 grit) grain abrasive. If the surface remains rough after a finishing cut, it may be necessary to use an even finer grain of abrasive (80-100grit). Care should be taken in selecting the grit size of the abrasive. A very fine grain will close the pores on a wood floor making admission of a stain difficult. If glazing or burning should occur the abrasive has dulled and must be replaced.

Troubleshooting

Problem	Possible Cause	Action
Motor will not start.	No Power.	Check power supply and connection.
	Interlock not depressed.	Depress interlock before activating control lever.
	Defective switch / bad connection.	Contact an authorized American Sanders Dealer.
Motor fails to start / runs sluggish.	Low voltage from excessive length or undersized extension cord.	Use a 12 Ga. extension cord, not to exceed 50 feet (15m) length.
	Defective start capacitor.	Contact an authorized American Sanders Dealer.
	Defective start switch.	Contact an authorized American Sanders Dealer.
	Defective run capacitor.	Contact an authorized American Sanders Dealer.
	Defective motor.	Contact an authorized American Sanders Dealer.
Fuse / circuit breaker repeatedly trips.	Low voltage.	Eliminate extension cord.
		Locate power source closer to work site.
		Have voltage checked by a qualified electrician.
	Bad connection.	Contact an authorized American Sanders Dealer.
	Defective motor.	Contact an authorized American Sanders Dealer.

LEA ESTE MANUAL

Este manual contiene información importante acerca del uso y la seguridad de la máquina. Si no lee el manual antes de utilizar su máquina American Sanders o de intentar realizar los procedimientos de reparación o mantenimiento de la misma, usted o el resto del personal podrían sufrir lesiones; asimismo, podrían producirse daños a la máquina o a otras propiedades. Antes de utilizar la máquina, es necesario recibir la capacitación adecuada en la operación de la misma.

Si el operador de la máquina no sabe leer en español, explíquelo el manual exhaustivamente antes de que intente utilizarla.

Todas las indicaciones incluidas en este manual se ofrecen desde la posición del operador en la parte posterior de la máquina.

Sección B - Contenido

Instrucciones De Seguridad Para El Operador.....	12
Introducción.....	13
Especificaciones De La máquina.....	13
Transporte De La Máquina.....	13
Instalación De La Máquina.....	14
Instrucciones De Seguridad.....	14
Recogida De Polvo.....	15
Instrucciones De Funcionamiento - Lijado.....	16
Instrucciones De Funcionamiento - Pulido.....	16
Cortes De Lija y Papel De Lija.....	16
Resolución De Problemas.....	17

Sección D - Repuestos Manual

Notes.....	26
Electrical Schematic.....	27
Base Assembly.....	28
Motor Assembly.....	30
Handle Assembly.....	32



ADVERTENCIA:

Los Productos a la venta en este Manual contienen, o pueden contener, productos químicos reconocidos por algunos gobiernos (como el Estado de California, según lo indica en su Proposición 65, Ley de Advertencia Regulatoria) como causantes de cáncer, defectos de nacimiento u otros daños reproductivos. En algunas jurisdicciones (incluido el Estado de California), los compradores de estos Productos que los coloquen en servicio en un emplazamiento laboral o en un espacio de acceso público tienen la obligación regulatoria de realizar determinados avisos, advertencias o divulgaciones respecto de los productos químicos contenidos o posiblemente contenidos en los Productos utilizados en tal lugar. Es la responsabilidad del comprador conocer y cumplir con todas las leyes y reglamentaciones relacionadas con el uso de estos Productos en tales entornos. El Fabricante niega toda responsabilidad de informar a los compradores sobre requisitos específicos que pueden regir el uso de los Productos en tales entornos.

*****Este producto está destinado exclusivamente para uso comercial*****



Instrucciones De Seguridad Para El Operador

En este manual de operación se encuentran tres declaraciones que usted debe leer y respetar para garantizar un funcionamiento seguro de la máquina.

PELIGRO significa: Usted u otras personas pueden estar expuestos a sufrir lesiones personales, inclusive la muerte si las indicaciones de **PELIGRO** que se encuentran en esta máquina o en el manual de instrucciones se ignoran o no se tienen en cuenta. Lea y respete todas las indicaciones de **PELIGRO** que se encuentran en el manual de instrucciones y en la máquina.

ADVERTENCIA significa: Usted u otras personas pueden estar expuestos a sufrir lesiones personales, si las indicaciones de **ADVERTENCIA** que se encuentran en esta máquina o en el manual de instrucciones se ignoran o no se tienen en cuenta. Lea y respete todas las indicaciones de **ADVERTENCIA** que se encuentran en el manual de instrucciones y en la máquina.

PRECAUCIÓN significa: La máquina u otros bienes pueden sufrir daños materiales si las indicaciones de **PRECAUCIÓN** que se encuentran en la máquina o en el manual de instrucciones se ignoran o no se tienen en cuenta. Lea y respete todas las indicaciones de **PRECAUCIÓN** que se encuentran en el manual de instrucciones y en la máquina.

-  **PELIGRO:**   Si no lee el manual de instrucciones antes de operar, reparar o realizar el mantenimiento de su máquina American Sanders, el resultado puede ser que usted o el resto del personal sufra lesiones. Asimismo, pueden producirse daños a la máquina o a otras propiedades. Antes de utilizar la máquina, es necesario recibir la capacitación adecuada en la operación de la misma. **Si usted o el operador no saben leer en inglés, haga que otra persona les explique el manual exhaustivamente antes de intentar utilizar la máquina.**
-  **PELIGRO:**  A. El lijado/acabado de pisos de madera puede crear un entorno explosivo. No utilice la máquina cerca de solventes, diluyentes, alcohol, combustibles, acabados de pisos, polvo de madera u otros materiales inflamables. Los encendedores, las lámparas indicadoras, las chispas eléctricas y cualquier otra fuente de ignición deben extinguirse o evitarse. Mantenga el área de trabajo bien ventilada.
B. El polvo que se genera al lijar pisos de madera puede encenderse o explotar espontáneamente. Elimine rápidamente el polvo de lijado en un recipiente de metal que no contenga ningún combustible. No arroje el polvo al fuego.
-  **PELIGRO:**  A. Puede producirse una electrocución si se repara o se realiza el mantenimiento de la máquina mientras se encuentra conectada a una fuente de alimentación. Desconecte la fuente de alimentación antes de realizar tareas de mantenimiento y reparación.
B. Si la máquina se utiliza con un cable de alimentación dañado podría producirse una electrocución o un incendio. Mantenga el cable de alimentación separado de la almohadilla. Pase siempre el cable por encima de la máquina. No utilice el cable de alimentación para mover la máquina.
C. Riesgo de descargas: No utilice la máquina si ha estado expuesta a la lluvia o ha sido rociada con agua.
-  **PELIGRO:**  Mantenga las manos, los pies y la vestimenta suelta alejados de todas las partes móviles de la máquina para evitar lesiones. Desconecte el cable de alimentación antes de reemplazar la almohadilla, cambiar el abrasivo y realizar mantenimiento o reparaciones. No utilice la máquina a no ser que todas sus protecciones estén en su lugar. Nunca deje la máquina sin vigilancia mientras está conectada a una fuente de alimentación.
-  **ADVERTENCIA:**  Si no se utilizan los dispositivos de protección personal correctos mientras se realiza el lijado, el operador o cualquier persona en el área de trabajo pueden sufrir lesiones. Utilice siempre protección respiratoria, ocular y auditiva mientras realice una operación de lijado.
-  **ADVERTENCIA:**  La pulidora no debe utilizarse sobre madera tratada a presión. Algunas maderas tratadas a presión contienen arsénico y si se pule madera tratada a presión produce un polvo nocivo. La inhalación de polvo nocivo de madera tratada a presión puede causar lesiones serias o la muerte. Pulir plataformas o superficies irregulares de madera tratada a presión puede dañar la Pulidora ques no está cubierto por la garantía ni por is Renuncia de Daños.
-  **ADVERTENCIA:** Cualquier alteración o modificación realizada a esta máquina puede producir daños a la misma o lesiones al operador o a otras personas que se encuentren en el lugar. Las alteraciones o modificaciones no autorizadas por el fabricante anulan todas las garantías y responsabilidades.
-  **ADVERTENCIA:** Riesgo de explosión. Lijado piso puede resultar en una mezcla explosiva de polvo fino y aire. Utilice piso lijado máquina sólo en un área bien ventilada y libre de toda llama o partido.

Introducción

La OBS-18 y la OBS-18DC pueden utilizarse en una gran variedad de superficies. Por ello, se trata de una herramienta ideal para mantenimiento de pisos de madera y trabajos de restauración. También es adecuada para la limpieza de superficies duras como baldosas o terrazo.

Especificaciones De La Máquina

Model	OBS-18
Número de código	07014A
Voltaje / Frecuencia	115V / 60Hz
Intensidad De Corriente (A)	10
Motor	1 hp 750 Watts
Tamaño De La Almohadilla	12" X 18" (305mm X 457mm)
Cable de Alimentación	40ft 12-3 Ga gris con revestimiento de goma
Giros Por Minuto	3600
Diámetro De Giro	1/4" (6.4mm)
Peso Del Envío	125 lbs (57 kg)
Ruido (dBA)	74
Vibración (m/s/s)	11.2

Transporte De La Máquina

To transport the machine, follow this procedure:

1. Desenchufe la máquina del tomacorriente de pared y enrolle el cable.
2. Eleve y bloquee la manija en posición vertical. Para trabar el mango, tire hacia arriba de la palanca de compresión de liberación del mango (Consulte la Figura 1).
3. Tome la máquina por los puntos de izado y colóquela en el área de carga (Consulte la Figura 2).

ADVERTENCIA: La máquina es pesada (125 lb / 57 kg). Para evitar daños a la misma o lesiones personales, sosténgala con firmeza y utilice la técnica de izado adecuada. De ser necesario, solicite ayuda.

4. Asegure la máquina para evitar movimientos en el área de carga.



Figura 1

Figura 2

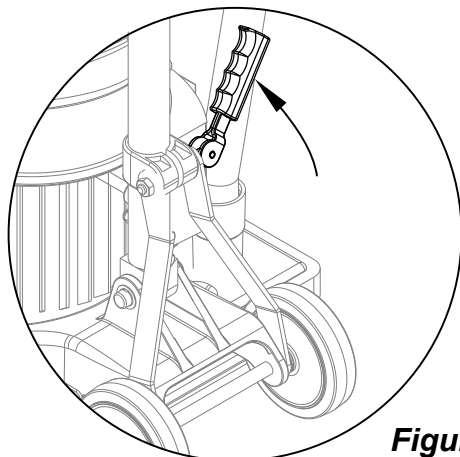
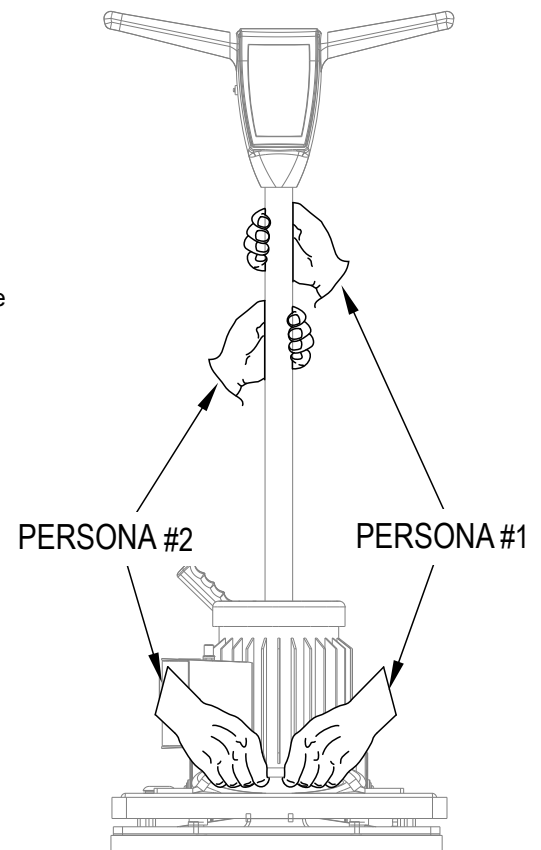

Instalación De La Máquina

Si desea preparar la máquina para su uso, siga este procedimiento:

1. Familiarícese con la máquina. Lea todas las indicaciones de peligro, advertencia y precaución, así como el manual de instrucciones y piezas, antes de utilizar la máquina. Si usted o el operador de la máquina no pueden leer este manual, haga que otra persona se lo explique exhaustivamente antes de intentar utilizarla.
2. Instale o reemplace la almohadilla. Si la almohadilla se ha desgastado a un espesor de 3/8" (9,5 mm) o menos, debe ser reemplazada. Para instalar o reemplazar la almohadilla, siga estas instrucciones:
 - A. Bloquee la manija en posición vertical.
 - B. Inclíne la máquina hacia atrás hasta que esté completamente apoyada en la manija.
 - C. Situándose sobre la máquina, retire la almohadilla existente y después centre la nueva almohadilla sobre el frente de agarre.
 - D. Presione la almohadilla contra el frente de agarre hasta que los ganchos se fijen en la almohadilla (Consulte la Figura 3).
 - E. Vuelva a situar la máquina en posición vertical.



Figura 3

- ⚠ ADVERTENCIA:** Mientras sustituye la almohadilla o cambia el abrasivo, nunca se sitúe usted mismo (ni deje que otras personas lo hagan) en una posición en la que pueda lesionarse si la máquina se inclina o cae.
- ⚠ PRECAUCIÓN:** El frente de agarre se daña si la máquina se opera sin una almohadilla o con una almohadilla cuyo grosor sea de 3/8" (9,5 mm) o menos.

Instrucciones De Seguridad

Esta máquina para pisos de acabado deberá estar conectada a tierra mientras esté en uso para proteger al operador de una descarga eléctrica. La máquina está provista de un cable de tres conductores y un accesorio de conexión a tierra de tres contactos de enchufe para adaptarse al receptáculo de conexión a tierra adecuada. El conductor verde (o verde y amarillo) en el cable es el cable a tierra. Nunca conecte este cable a otro que el pasador de puesta a tierra del enchufe.

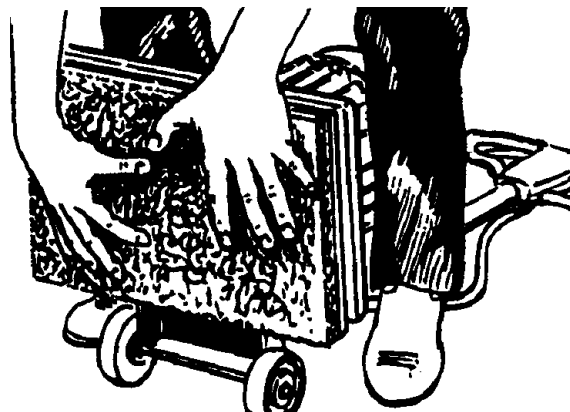
Esta máquina es para uso en un circuito nominal de 120 voltios y tiene un enchufe de conexión a tierra que se parece al enchufe illustrated como (A) en el boceto. Asegúrese de que la máquina está conectada a un tomacorriente que tenga la misma configuración que el enchufe. Sin adaptador se debe utilizar con esta máquina.

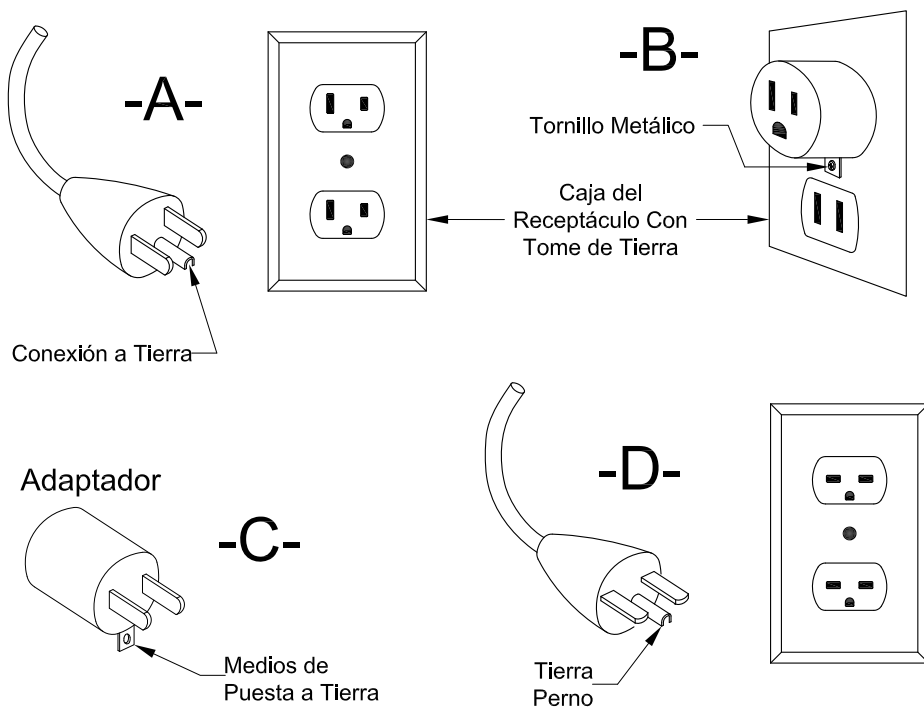

Recogida De Polvo

Esta lijadora está diseñada para utilizarse con un sistema colector de polvo remoto mediante vacío o con la bolsa de polvo incluida

Preparación de los sistemas colectores de polvo remotos mediante vacío

Si desea preparar la máquina para sistemas colectores de polvo remotos mediante vacío que tengan un extremo de manguera de 2", siga este procedimiento:

1. Instale el extremo de manguera de 2" (Figura 4-A) directamente sobre el tubo de escape (Figura 4-B).
2. El tubo de escape puede girarse para mayor comodidad.

Si desea preparar la máquina para sistemas colectores de polvo remotos mediante vacío que tengan un extremo de manguera de 1-1/2", siga este procedimiento:

1. Instale el adaptador del extremo de manguera de 2" x 1½" (No de pieza 30563A) (Figura 4-C) sobre el tubo de escape (Figura 4-B).
2. Inserte el extremo de manguera de 1½" (Figura 4-D) en el adaptador (Figura 4-C).

NOTA: Ponga en marcha el sistema colector remoto mediante vacío antes de encender la máquina.

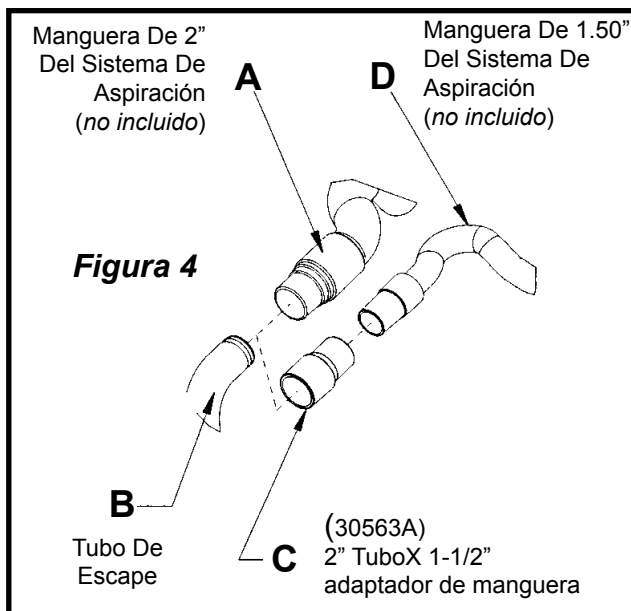

Preparación para usar la bolsa de polvo incluida

Si desea preparar la máquina para su uso con la bolsa de polvo incluida (No de pieza 53741A), siga este procedimiento:

1. Instale la bolsa de recolección de polvo presionando el extremo del tubo de escape hasta que el anillo encaje dentro de la ranura (Figura 5). El mejor modo de hacer esto es presionando la parte posterior de la abertura de la bolsa con la palma de su mano.
2. El tubo de escape puede girarse para mayor comodidad.
3. Para retirar la bolsa de polvo del tubo de escape, haga palanca hacia arriba en el extremo de la abertura de la bolsa para liberar parcialmente el saliente interno de la ranura, y después tire.
4. Para vaciar la bolsa de polvo, abra la aleta de vaciado y saque sus contenidos dando la vuelta a la bolsa.

NOTE: Para lograr los mejores resultados, vacíe frecuentemente. Siga todas las advertencias incluidas en el manual y en la bolsa de polvo.

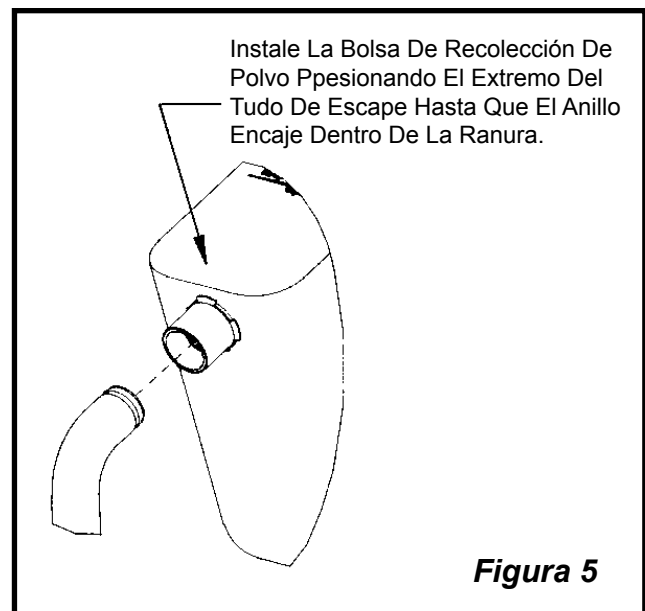

Instrucciones De Funcionamiento - Lijado

Para operar la máquina como una lijadora, siga este procedimiento:

1. Desplace la máquina al lugar de trabajo. Seleccione el mejor método para lijar el área deseada. Mientras lija dicha área, trabaje de manera tal que usted se aleje de la fuente de alimentación. Esto ayudará a evitar que el cable de alimentación se enrede y reduce la necesidad de mover dicho cable con tanta frecuencia.
2. Instale el abrasivo. Para instalar el abrasivo, utilice el mismo procedimiento descrito en INSTALACIÓN DE LA MÁQUINA para la instalación de la almohadilla. Retire la película de la parte posterior del abrasivo, centre el mismo sobre la almohadilla y presiónelo contra ésta. El adhesivo del abrasivo lo sostendrá en la almohadilla.

NOTA: Si utiliza abrasivo de tela metálica, sitúe la tela metálica sobre el suelo y a continuación desplace la máquina sobre la misma. Baje la máquina hasta que la almohadilla se apoye sobre la tela metálica. Asegúrese de que la tela metálica esté centrada en la almohadilla.

ADVERTENCIA: Puede producirse una lesión si se instalan la almohadilla o el abrasivo mientras la máquina se encuentra conectada a una fuente de alimentación. Desconecte la máquina antes de instalar la almohadilla o el abrasivo.

3. Conecte la máquina a un circuito adecuadamente provisto de fusibles y conectado a tierra.
4. Suelte la manija presionando la palanca de bloqueo. Sitúe la manija en una posición cómoda.

PRECAUCIÓN: no bloquee la manija. Si se bloquea la manija, la máquina no podrá reposar de forma uniforme en la almohadilla y disminuirán el rendimiento de la máquina y su fiabilidad.

5. Pulse el botón de interbloqueo (1) y aplique presión a las palancas (2). Para detener la máquina, suelte las palancas (2). Consulte la Figura 6.

PRECAUCIÓN: para evitar daños al piso y reducir los remolinos, mantenga la máquina en movimiento mientras el motor esté funcionando.



Figura 6

Instrucciones De Funcionamiento - Pulido

Para operar la máquina como una pulidora siga este procedimiento:

ADVERTENCIA: puede producirse una lesión si se instalan la almohadilla o el abrasivo mientras la máquina se encuentra conectada a una fuente de alimentación. Desconecte la máquina antes de instalar la almohadilla o el abrasivo.

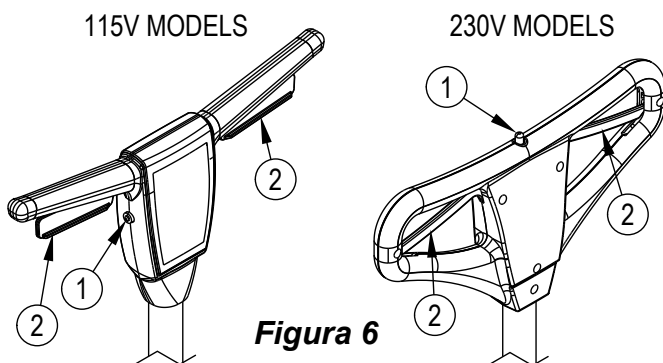
1. Conecte la máquina a un circuito adecuadamente provisto de fusibles y conectado a tierra.
2. Suelte la manija presionando la palanca de bloqueo. Sitúe la manija en una posición cómoda.

PRECAUCIÓN: No bloquee la manija. Si se bloquea la manija, la máquina no podrá reposar de forma uniforme en la almohadilla y disminuirán el rendimiento de la máquina y su fiabilidad.

3. Pulse el botón de interbloqueo (1) y aplique presión a las palancas (2). Para detener la máquina, suelte las palancas (2). Consulte la Figura 6.

PRECAUCIÓN: Para evitar dañar el suelo y reducir los remolinos, mantenga la máquina en movimiento mientras el motor esté en funcionamiento.

Cortes De Lija Y Papel De Lija

Corte Inicial:

El propósito del corte inicial es sacar el acabado viejo y las imperfecciones mayores de la superficie del piso. Se debe usar un abrasivo grueso (20-36 granos).

Cortes Finales:

El propósito de un corte de acabado es eliminar los rayones producidos durante el corte inicial. Utilice un abrasivo de grano fino (60-80 granos). Si la superficie permanece áspera después de un corte de acabado, puede ser necesario utilizar un abrasivo de grano aún más fino (80 - 100 granos). Se deberá tener cuidado al seleccionar el tamaño del grano del abrasivo. Un grano muy fino cerrará los poros sobre el piso de madera dando lugar a problema de manchas. Si un corte de acabado apareciera inmediatamente glaseado o quemado, aumente el ritmo. Si esto ocurriera durante un corte final, significa que el abrasivo se ha desafilado y deberá cambiarse.

Resolución De Problemas

Problema	Causa	Acción
El motor no arranca.	No hay potencia.	Inspeccione la fuente de alimentación y la conexión.
	El interbloqueo no está presionado.	Presione el interbloqueo antes de activar la palanca de control.
	Interruptor defectuoso / mala conexión.	Póngase en contacto con un distribuidor autorizado de American Sanders.
El motor no arranca / funciona.	Tensión baja debido a cable demasiado largo.	Use un alargador de calibre 12, que demasiado largo no sea lento. o demasiado corto. supere los 50 feet (15m) de longitud.
	El capacitor de arranque es defectuoso.	Póngase en contacto con un distribuidor autorizado de American Sanders.
	El interruptor de arranque es defectuoso.	Póngase en contacto con un distribuidor autorizado de American Sanders.
	Capacitor de funcionamiento defectuoso.	Póngase en contacto con un distribuidor autorizado de American Sanders.
	Baja tensión del motor defectuosa.	Póngase en contacto con un distribuidor autorizado de American Sanders.
El fusible / disyuntor se disparan veces.	Baja tensión.	Retire el alargador.
		Localice la fuente eléctrica más cercana al lugar de trabajo.
		Haga que la tensión sea inspeccionada por un electricista calificado.
	Conexión defectuosa.	Póngase en contacto con un distribuidor autorizado de American Sanders.
	El motor es defectuoso.	Póngase en contacto con un distribuidor autorizado de American Sanders.

LISEZ CE MANUEL

Ce Manuel contient des informations importantes concernant l'utilisation et le fonctionnement de cette machine dans des conditions de sécurité optimales. La non-lecture de ce manuel avant d'utiliser ou d'entretenir votre machine American Sanders risque de provoquer un accident ou d'endommager la machine ou son environnement. Vous devez avoir été formé à l'utilisation de cette machine avant de l'utiliser. Si l'opérateur n'est pas en mesure de lire ce Manuel, il devra se le faire expliquer entièrement avant de tenter d'utiliser cette machine.

Toutes les directions données dans ce Manuel le sont par rapport à la position de l'opérateur, à l'arrière de la machine.

Section C - Contenu De Ce Manuel

Consignes De Sécurité.....	19
Introduction.....	20
Spécifications De L'appareil.....	20
Transport De L'appareil.....	20
Préparation De L'appareil.....	21
Consignes De Sécurité.....	21
Collecte Des Poussières.....	22
Utilisation De L'appareil – Ponçage.....	23
Utilisation De L'appareil – Polissage.....	23
Ponçage Et Papier Abrasif.....	23
Dépannage.....	24

Section D - Manuel De Pièces

Notes.....	26
Electrical Schematic.....	27
Base Assembly.....	28
Motor Assembly.....	30
Handle Assembly.....	32

AVERTISSEMENT:

Les produits vendus avec ce manuel contiennent ou peuvent contenir des produits chimiques qui sont connus pour certains gouvernements (tels que l'État de California, comme indiqué dans son droit réglementaire Proposition 65 Warning) pour causer le cancer, des malformations congénitales ou d'autres problèmes de reproduction. Dans certains endroits (y compris l'Etat de California) acheteurs de ces produits qui les placent en service à un chantier de travail ou un espace accessible au public sont requis par la réglementation pour faire certaines affiches, des avertissements ou des informations concernant les produits chimiques qui sont ou peuvent être contenus dans les produits à ou vers ces sites de travail. Il est de la responsabilité de l'acheteur de connaître le contenu de, et à se conformer à ces lois et règlements relatifs à l'utilisation de ces produits dans de tels environnements. Le fabricant décline toute responsabilité d'informer les acheteurs de toutes les exigences spécifiques qui peuvent être applicables à l'utilisation des produits dans de tels environnements.

*****Ce produit est destiné pour une utilisation commerciale*****



Consignes De Sécurité

Dans ce manuel d'utilisation, vous trouverez trois déclarations que vous devez lire et d'observer pour assurer la sécurité de cette machine.

DANGER signifie: Si une consigne **DANGER** figurant dans ce manuel d'utilisation ou sur l'appareil n'est pas respectée ou suivie, des blessures graves, voire mortelles, peuvent vous arriver ainsi qu'à d'autres personnes. Lisez et observez toutes les consignes **DANGER** apparaissant sur l'appareil ou dans votre manuel d'utilisation.

AVERTISSEMENT signifie: Si une consigne **AVERTISSEMENT** figurant dans ce manuel d'utilisation ou sur l'appareil n'est pas respectée ou suivie, des blessures peuvent vous arriver ainsi qu'à d'autres personnes. Lisez et observez toutes les consignes **AVERTISSEMENT** apparaissant sur l'appareil ou dans votre manuel d'utilisation.

ATTENTION signifie: Si une consigne **ATTENTION** figurant dans ce manuel d'utilisation ou sur l'appareil n'est pas respectée ou suivie, vous risquez d'endommager l'appareil et de causer divers dommages matériels. Lisez et observez toutes les consignes **ATTENTION** apparaissant sur l'appareil ou dans votre manuel d'utilisation.

-  **DANGER:**  Si vous ne lisez pas le manuel d'utilisation avant d'utiliser ou réparer votre appareil American Sanders, vous risquez de vous blesser ainsi que d'autres personnes. Vous risquez également d'endommager l'appareil et de causer divers dommages matériels. Avant d'utiliser cet appareil, vous devez avoir reçu une formation sur son utilisation. Si un utilisateur est incapable de lire ce manuel, il doit en demander une explication complète avant d'utiliser l'appareil.
-  **DANGER:**  A. Le ponçage des parquets de bois peut créer un environnement explosif ou combustible. Ne pas utiliser cet appareil à proximité de solvants, de diluants, d'alcool, de carburant, de poussière de bois ou d'autres matériaux inflammables. Les vapeurs et la poussière de bois produites par le ponçage des parquets peuvent créer un environnement explosif. Les briquets, les témoins lumineux, les étincelles électriques et toutes les autres sources d'allumage doivent être éteints. Garder la zone de travail bien aérée.
B. La poussière produite par le ponçage d'un parquet de bois peut exploser ou s'enflammer soudainement. Jeter sans délai toute la poussière de ponçage dans un récipient métallique ne contenant aucun combustible. Ne pas jeter au feu.
-  **DANGER:**  A. Une électrocution peut survenir si l'appareil est réparé alors qu'il est raccordé à une source d'alimentation électrique. Déconnecter l'alimentation électrique avant toute réparation.
B. Une électrocution ou incendie peuvent survenir si l'appareil est utilisé avec un cordon d'alimentation électrique endommagé. Le cordon d'alimentation doit demeurer à bonne distance du patin de ponçage. Le cordon doit toujours être soulevé au-dessus de l'appareil. Ne jamais tirer l'appareil par le cordon d'alimentation.
C. Risque d'électrocution. Ne pas utiliser l'appareil s'il a été exposé à la pluie ou arrosé avec de l'eau.
-  **DANGER:**  Pour éviter les blessures, il faut toujours garder les mains, les pieds et les vêtements amples à bonne distance des pièces mobiles de l'appareil. Le cordon d'alimentation doit être débranché avant de remplacer le patin de ponçage ou le papier abrasif, ainsi qu'avant toute réparation. Ne pas utiliser l'appareil si toutes les protections ne sont pas en place. Ne jamais laisser l'appareil sans surveillance lorsqu'il est branché à une alimentation électrique.
-  **AVERTISSEMENT:**  L'opérateur, ou toute personne à proximité, doit porter une tenue de protection en cours de ponçage pour prévenir les blessures. Utilisez toujours une protection oculaire et auditive ainsi qu'un appareil respiratoire lors de tout ponçage/sablage.
-  **AVERTISSEMENT:**  La ponceuse ne doit pas être utilisée sur du bois traité sous pression. Certains bois traités sous pression contiennent de l'arsenic, le ponçage du bois traité sous pression produit des poussières dangereuses. L'inhalation de poussières dangereuse produite par du bois traité sous pression risque d'entraîner la mort ou de graves blessures. Le ponçage de bois traité sous pression ou de surfaces irrégulières risque d'endommager la ponceuse qui n'est pas converti ni par la garantie ni par les Exonérations de Dommages.
-  **AVERTISSEMENT:** Toute modification apportée à cet appareil peut l'endommager et blesser l'opérateur ou des passants. Les modifications non autorisées par le fabricant annulent toutes les garanties et responsabilités.
-  **AVERTISSEMENT:** Risque d'explosion. Ponçage du sol peut entraîner un mélange explosif de poussières fines et de l'air. Utilisez la machine de ponçage uniquement dans un endroit bien aéré et libre de toute flamme ou d'un match.

Introduction

Les appareils OBS-18 et OBS-18DC peuvent être utilisés sur une grande variété de surfaces. C'est un outil idéal pour l'entretien et la remise à neuf des parquets. Il permet également de nettoyer diverses surfaces dures, comme le carrelage en céramique et le granito.

Spécifications De L'appareil

Model	OBS-18
Numéro De Code	07014A
Tension / Fréquence	115V / 60Hz
Instensité (A)	10
Moteur	1 hp 750 Watts
Dimensions Du Patin	12" X 18" (305mm X 457mm)
Câble D'alimentation	40ft 12-3 Cordon en Caoutchouc Gris
Orbites Par Minute	3600
Diamètre Des Orbites	1/4" (6.4mm)
Poids à L'expédition	125 lbs (57 kg)
Bruit (dBA)	74
Vibrations (m/s/s)	11.2

Transport De L'appareil

Pour transporter l'appareil, exécutez les opérations suivantes:

1. Débranchez la fiche de branchement électrique de l'appareil, puis enroulez le cordon d'alimentation.
2. Relevez le manche de l'appareil et bloquez-le en position droite. Pour bloquer le manche, tirez le levier de blocage par compression du manche vers le haut (voir la figure 1).
3. Saisissez l'appareil aux points de levage et placez-le dans le compartiment de transport (voir la figure 2).



AVERTISSEMENT: L'appareil est lourd (125 livres/57 kg). Pour éviter de vous blesser et d'endommager l'appareil, utilisez une prise solide et une bonne technique de levage. Demandez de l'aide si nécessaire.

4. Attachez l'appareil pour éviter qu'il ne bouge sur le véhicule de transport.

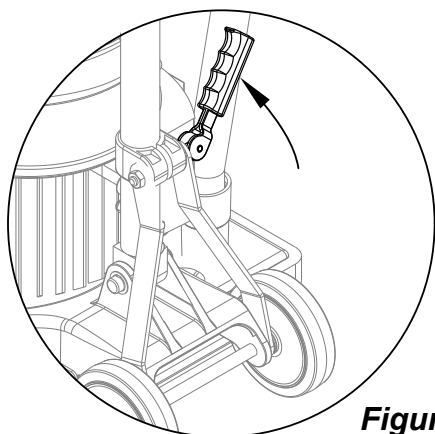
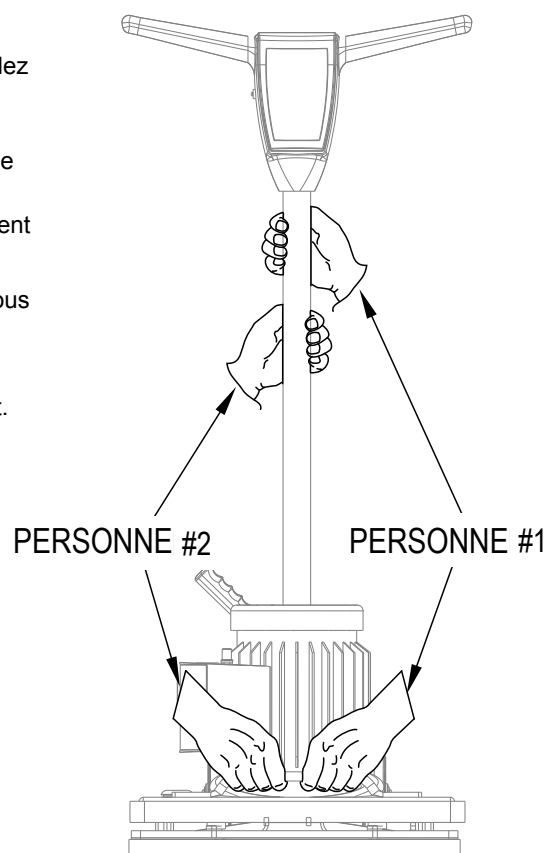

Figure 1

Figure 2



Préparation De L'appareil

Pour préparer l'appareil avant une utilisation, exécutez les opérations suivantes:

1. Familiarisez-vous avec l'appareil. Avant toute utilisation de l'appareil, lisez les avertissements, les consignes de sécurité et le manuel d'utilisation. Si un utilisateur est incapable de lire ce manuel, il doit en demander une explication complète avant d'utiliser l'appareil.
2. Installez ou remplacez le patin de ponçage. Il doit être remplacé s'il est usé jusqu'à une épaisseur égale ou inférieure à 3/8 po. Pour installer ou remplacer le patin de ponçage, exécutez les opérations suivantes:
 - A. Verrouillez le manche en position redressée.
 - B. Inclinez l'appareil vers l'arrière jusqu'à ce qu'il repose complètement sur les poignées.
 - C. En vous tenant au-dessus de l'appareil, enlevez le vieux patin de ponçage et centrez un nouveau patin sur le plateau de ponçage auto-agrippant.
 - D. Appuyez le patin contre le plateau de ponçage auto-agrippant jusqu'à ce que les crochets de le plateau de ponçage auto-agrippant aient accrochés le patin (voir la Figure 3).
 - E. Redressez l'appareil.

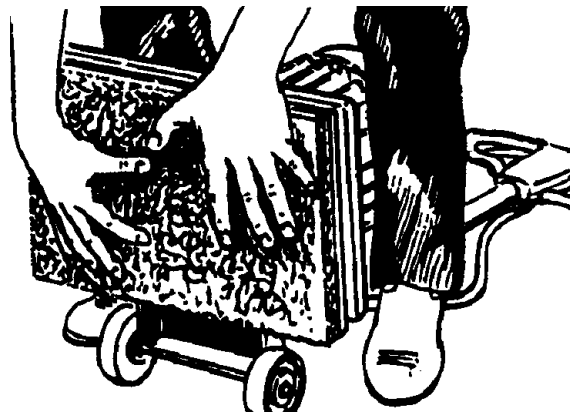

Figure 3

ATTENTION: Le plateau de ponçage auto-agrippant sera endommagée si l'appareil est utilisé sans patin de ponçage ou avec un patin d'une épaisseur égale ou inférieure à 3/8 po.

AVERTISSEMENT: Lorsque vous remplacez le patin de ponçage ou le papier abrasif, ne vous placez pas et ne laissez pas d'autres personnes se placer dans une position pouvant provoquer une blessure si l'appareil venait à basculer ou se.

Consignes De Sécurité

Cette machine doit être mise à la terre lors de son utilisation pour protéger l'utilisateur contre les chocs électriques. La machine est équipée d'un cordon à trois conducteurs et une prise de fixation avec mise à la terre de type «trois contacts» pour s'adapter à la prise de terre appropriée. Le conducteur vert (ou vert et jaune) dans le cordon est le fil de mise à la terre. Ne jamais connecter ce fil autre que à la broche de mise à la terre de la prise de fixation.

Cette machine doit être utilisée sur un circuit nominal de 120 volts et a une fiche de mise à la terre qui ressemble à la fiche illustrée par (A) dans l'esquisse. Assurez-vous que la machine est connectée à une prise ayant la même configuration que la fiche. Aucun adaptateur ne doit être utilisé avec cette machine.

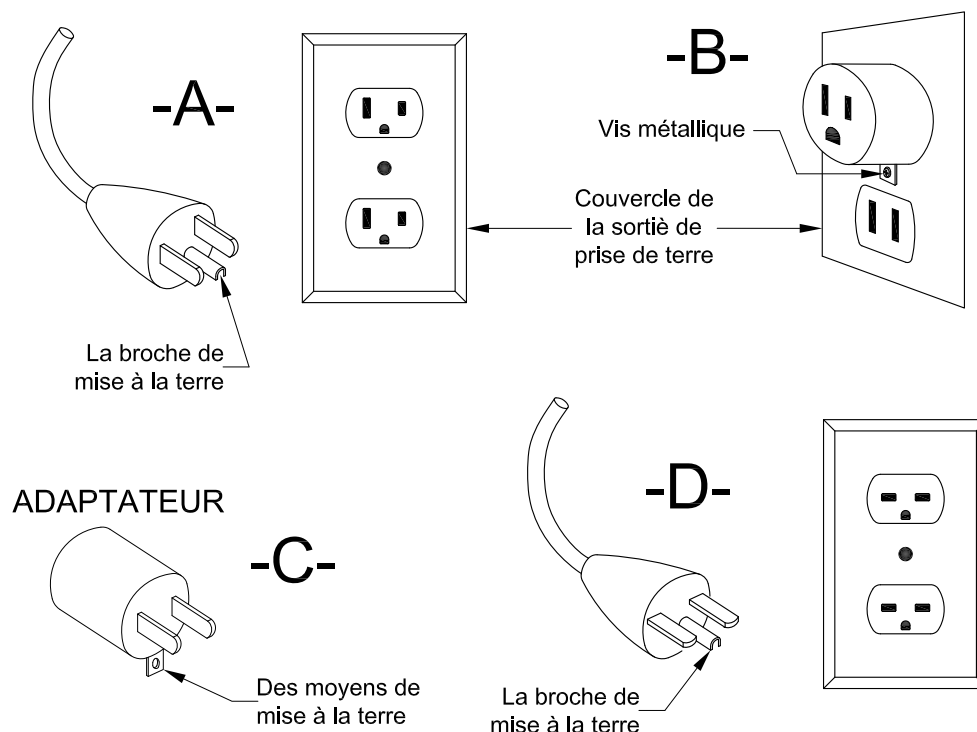

Collecte Des Poussières

Cette ponceuse est conçue pour fonctionner équipée d'un système à distance de collecte des poussières par le vide, ou du sac à poussières fourni.

Préparation des systèmes à distance de collecte des poussières par le vide

Pour préparer la machine à l'utilisation d'un système à distance de collecte des poussières par le vide ayant une extrémité de tuyau de 5 cm, procéder comme suit:

1. Monter l'extrémité de tuyau de 5 cm (Figure 4, A) directement sur le tuyau d'évacuation (Figure 4, B).
2. Il est possible de tourner le tuyau d'évacuation pour plus de commodité.

Pour préparer la machine à l'utilisation d'un système à distance de collecte des poussières par le vide ayant une extrémité de tuyau de 3,80 cm, procéder comme suit:

1. Monter l'adaptateur d'extrémité de tuyau (5 x 3,8 cm- Pièce no 30563A) (Figure 4, C) sur le tuyau d'évacuation (Figure 4, B).
2. Introduire l'extrémité de tuyau de 3,80 cm (Figure 4, D) dans l'adaptateur (Figure 4, C).

NOTE: Faire démarrer le système à distance de collecte par le vide avant de travailler.

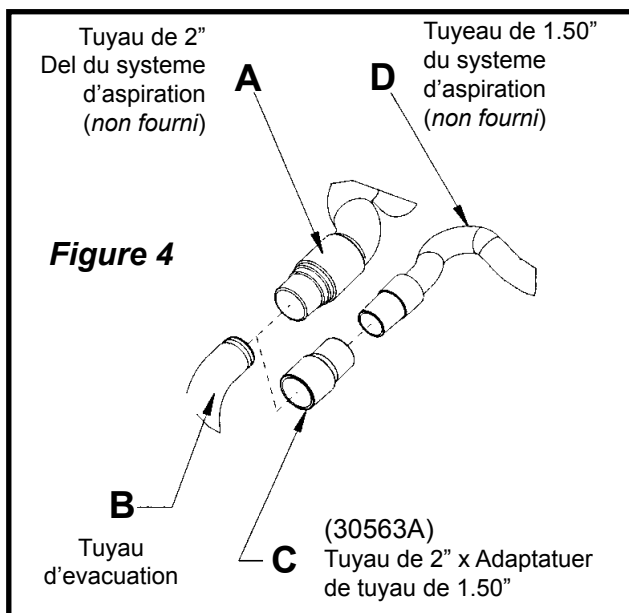

Préparation pour utilisation du sac à poussières fourni

Pour préparer la machine à l'utilisation du sac à poussières fourni (Pièce no 53741A), procéder comme suit:

1. Installez le sac à poussières en appuyant son extrémité sur le tuyau d'évacuation jusqu'à ce que l'anneau se verrouille dans la rainure (Figure 5). On y parvient plus facilement en appuyant sur l'arrière de l'ouverture du sac avec la paume de la main.
2. Il est possible de tourner le tuyau d'évacuation pour plus de commodité.
3. Pour retirer le sac à poussières du tuyau d'évacuation, soulever l'extrémité de l'ouverture du sac pour partiellement dégager la nervure interne de la rainure, puis tirer.
4. Pour vider le sac à poussières, ouvrir la fermeture éclair de la trappe d'évacuation des déchets et expulser le contenu en retournant le sac.

NOTE: Pour obtenir les meilleurs résultats, vider fréquemment le sac. Respecter toutes les mises en garde indiquées dans le présent manuel et sur le sac à poussières.

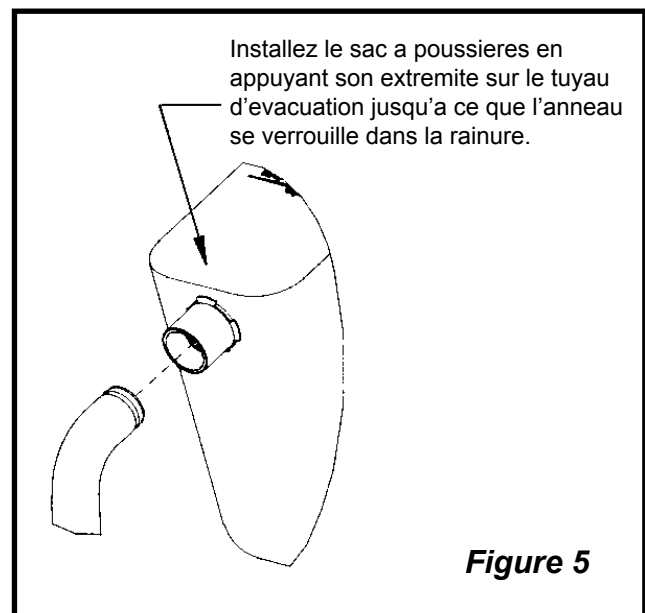

Utilisation De L'appareil – Ponçage

Pour poncer avec l'appareil, exécutez les opérations suivantes:

1. Déplacez l'appareil jusqu'au site de ponçage. Choisissez la meilleure approche pour poncer la zone à traiter. Lorsque vous ponchez une zone, déplacez-vous de façon à vous éloigner de la prise électrique. Vous réduirez ainsi les risques d'emmêler le cordon et vous serez moins souvent contraint de déplacer le cordon.
2. Installez le papier abrasif. Pour ce faire, utilisez la procédure d'installation du patin de ponçage décrite sous PRÉPARATION DE L'APPAREIL. Décollez la pellicule protectrice derrière le papier abrasif, centrez le papier sur le patin de ponçage et appuyez sur le papier pour le coller au patin. L'adhésif se trouvant sur le papier suffit pour le retenir sur le patin.

REMARQUE: Lorsque vous utilisez un abrasif grillagé, posez le grillage sur le sol, puis placez l'appareil au-dessus du grillage. Abaissez l'appareil jusqu'à ce que le patin de ponçage repose sur le grillage. Assurez-vous que le grillage est centré sur le patin.

AVERTISSEMENT: Des blessures peuvent survenir si l'appareil est raccordé à une source d'alimentation électrique pendant que vous installez un patin de ponçage ou un papier abrasif. Débranchez l'appareil avant toute installation d'un patin ou d'un papier abrasif.

3. Connectez l'appareil à un circuit électrique adéquatement mis à la terre et protégé par un fusible ou un disjoncteur.
4. Débloquez le manche en relevant le levier de verrouillage. Descendez le manche jusqu'à une hauteur confortable.

ATTENTION: Ne pas verrouiller le manche de l'appareil. Verrouiller la manche empêchera l'appareil de reposer également sur le coussin et diminue l'exécution de machine.

5. Pousser sur le bouton de verrouillage (1) et appliquer une pression des mains sur les leviers (2). Pour arrêter l'appareil, relâchez les leviers (Voir fig. 5).

ATTENTION: Pour éviter d'endommager les parquets et pour réduire le tourbillonnement, gardez l'appareil en mouvement lorsque le moteur fonctionne.

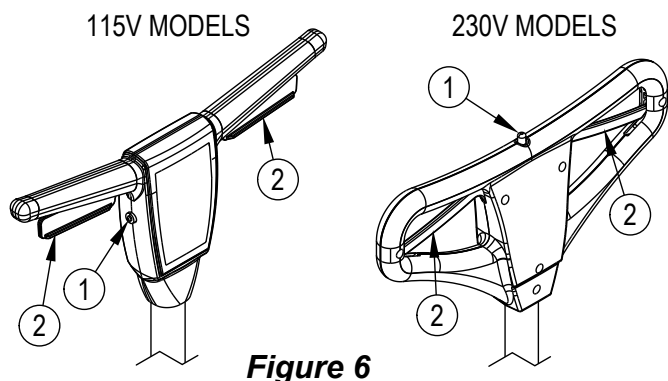

Figure 6

Utilisation De L'appareil – Polissage

Pour polir avec l'appareil, exécutez les opérations suivantes:

ADVERTENCIA: Des blessures peuvent survenir si l'appareil est raccordé à une source d'alimentation électrique pendant que vous installez un patin de ponçage ou un papier abrasif. Débranchez l'appareil avant toute installation d'un patin ou d'un papier abrasif.

1. Connectez l'appareil à un circuit électrique adéquatement mis à la terre et protégé par un fusible ou un disjoncteur.
2. Débloquez le manche en relevant le levier de verrouillage. Descendez le manche jusqu'à une hauteur confortable.

ATTENTION: Ne pas verrouiller le manche de l'appareil. Verrouiller la manche empêchera l'appareil de reposer également sur le coussin et diminue l'exécution de machine.

3. Pousser sur le bouton de verrouillage (1) et appliquer une pression des mains sur les leviers (2). Pour arrêter l'appareil, relâchez les leviers (Voir fig. 4).

ATTENTION: Pour éviter d'endommager les parquets et pour réduire le tourbillonnement, gardez l'appareil en mouvement lorsque le moteur fonctionne.

Ponçage Et Papier Abrasif

Premier passage:

Le but du premier passage est d'enlever l'ancienne finition et les plus grosses imperfections. Utilisez un papier abrasif à gros grains (20-36 grains).

Passages finaux:

Le but d'un passage final est d'enlever les rayures produites durant le premier passage. Utilisez un papier abrasif à petits grains (60-80 grains). Si la surface demeure rugueuse après un passage final, il pourrait être nécessaire d'utiliser un papier abrasif à grains plus fins (80-100 grains). La grosseur des grains abrasifs doit être choisie avec soin. Un grain trop fin risque de refermer les pores du bois, nuisant ainsi à l'absorption ultérieure de la teinture. Si vous détectez une vitrification ou des traces de brûlure, le papier abrasif s'est émoussé et doit être remplacé.

Dépannage

Problème	Cause	Solution
Le moteur ne démarre pas.	Aucune alimentation électrique.	Vérifiez l'alimentation électrique et les connexions.
	Le verrou n'est pas enfoncé.	Enfoncez le verrou avant d'actionner la manette de commande.
	Interrupteur défectueux, mauvaise connexion.	Contactez un détaillant American Sanders agréé.
El motor no arranca / funciona.	Tension faible à cause d'une rallonge trop longue ou trop fine.	Utilisez une rallonge électrique de grosseur 12 ne dépassant pas 50 pieds (15m).
	Défectuosité du condensateur de démarrage.	Contactez un détaillant American Sanders agréé.
	Défectuosité du démarreur.	Contactez un détaillant American Sanders agréé.
	Défectuosité du condensateur de démarrage/fonctionnement.	Contactez un détaillant American Sanders agréé.
	Problème de tension faible dans le moteur.	Contactez un détaillant American Sanders agréé.
Le fusible ou le disjoncteur saute se très souvent.		Éliminez la rallonge électrique.
	Tension trop faible.	Trouvez une source d'alimentation électrique plus proche du site.
		Faites vérifier la tension électrique par un électricien.
	Mauvaise connexion.	Contactez un détaillant American Sanders agréé.
	Moteur défectueux.	Contactez un détaillant American Sanders agréé.

Electrical Schematic (115V - 60Hz)

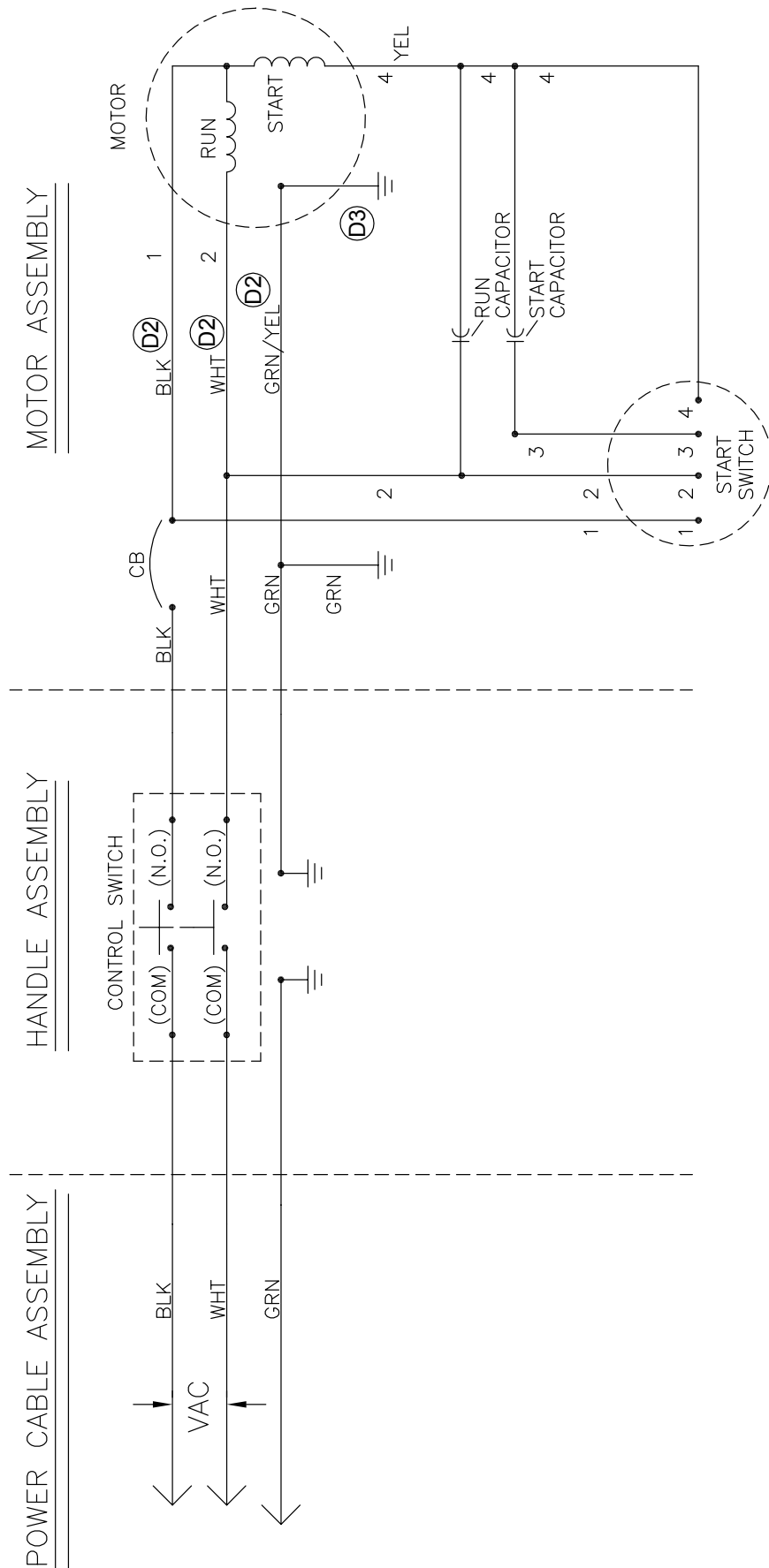

Base Assembly

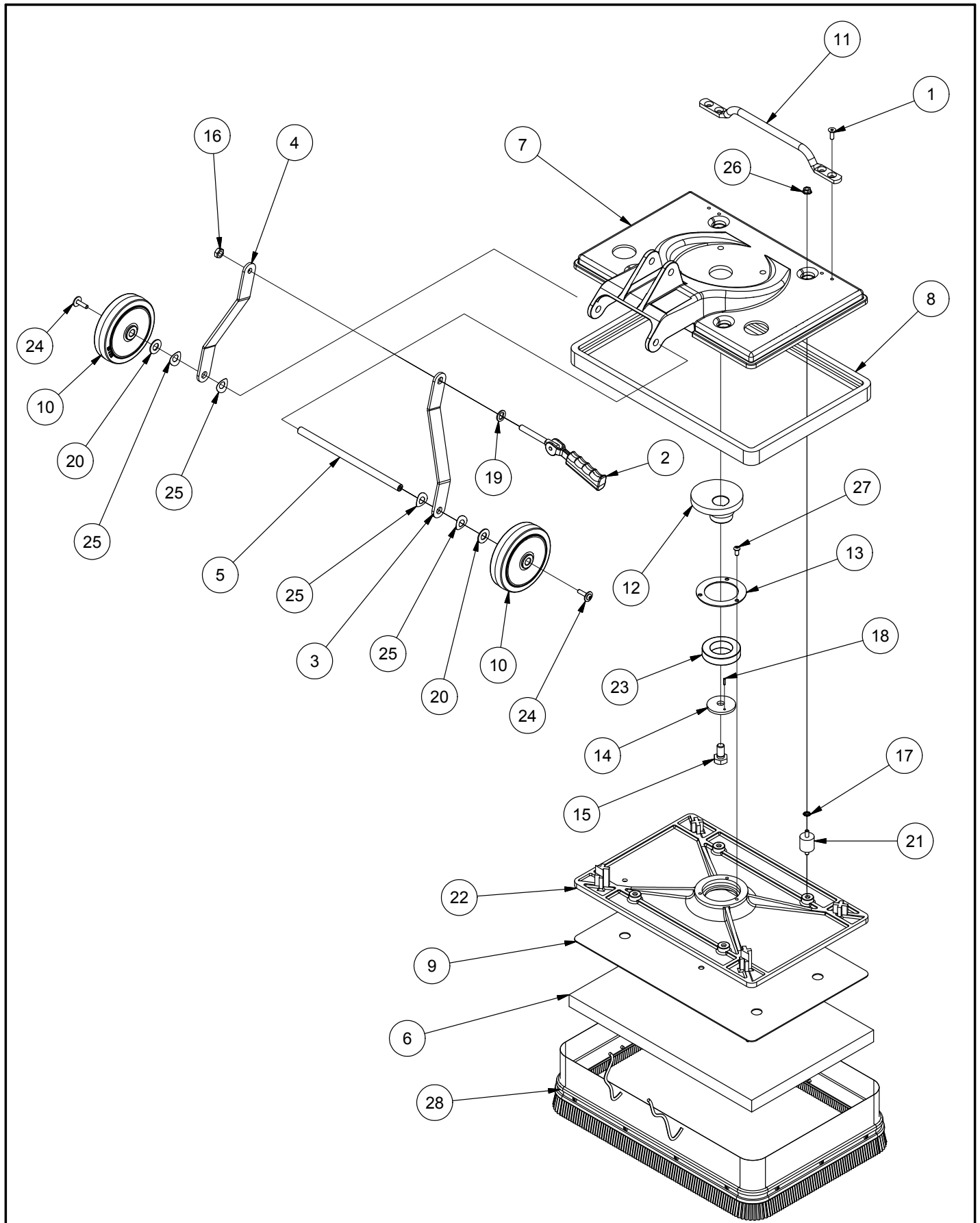

Base Assembly (continued)

<u>Item</u>	<u>Ref. No.</u>	<u>Description</u>	<u>Qty</u>	<u>Item</u>	<u>Ref. No.</u>	<u>Description</u>	<u>Qty</u>
1	962411	SCREW, 1/4" X 3/4", CS	4	15	85718A	SCREW, 1/2" X 3/4", SH	1
2	56109699	CAM ASM, w/ GRIP	1	16	920248	NUT, 3/8"	1
3	56381766	LINK-ARM, RIGHT	1	17	980614	WASHER, 1/4", STAR LOCK	4
4	56381767	LINK-ARM, LEFT	1	18	925589	PIN, ROLL	1
5	56381768	SHAFT, AXLE	1	19	980349	WASHER, WEAR, CAM	1
6	56382759	PAD, RED, 12" X 18"	1	20	980648	WASHER, 17/32" X 1-1/16"	2
7	25908A	MAINFRAME, OBS-18DC	1	21	10666A	SPRING MOUNT KIT	1
8	31224B	BUMPER, FRAME (BLACK)	1	22	29931A	BASE, ORBITAL	1
9	AS009400	GRIP FACE	1	23	50736A	BEARING	1
10	39857A	WHEEL, 5" X 1.50" X .50"	2	24	80292A	SCREW, 1/4" X 1"	2
11	54930A	HANDLE, LIFT	1	25	80295A	WASHER, BOWED	4
12	62814A	ECCENTRIC	1	26	81220A	NUT, SERRATED FLANGE	4
13	66981A	RETAINER, BEARING	1	27	87700A	SCREW, 1/4" X 1/2" BH	3
14	66982A	RETAINER, ECCENTRIC	1	28	18445A	SKIRT, DUST, ASM. (DC)	1

Motor Assembly

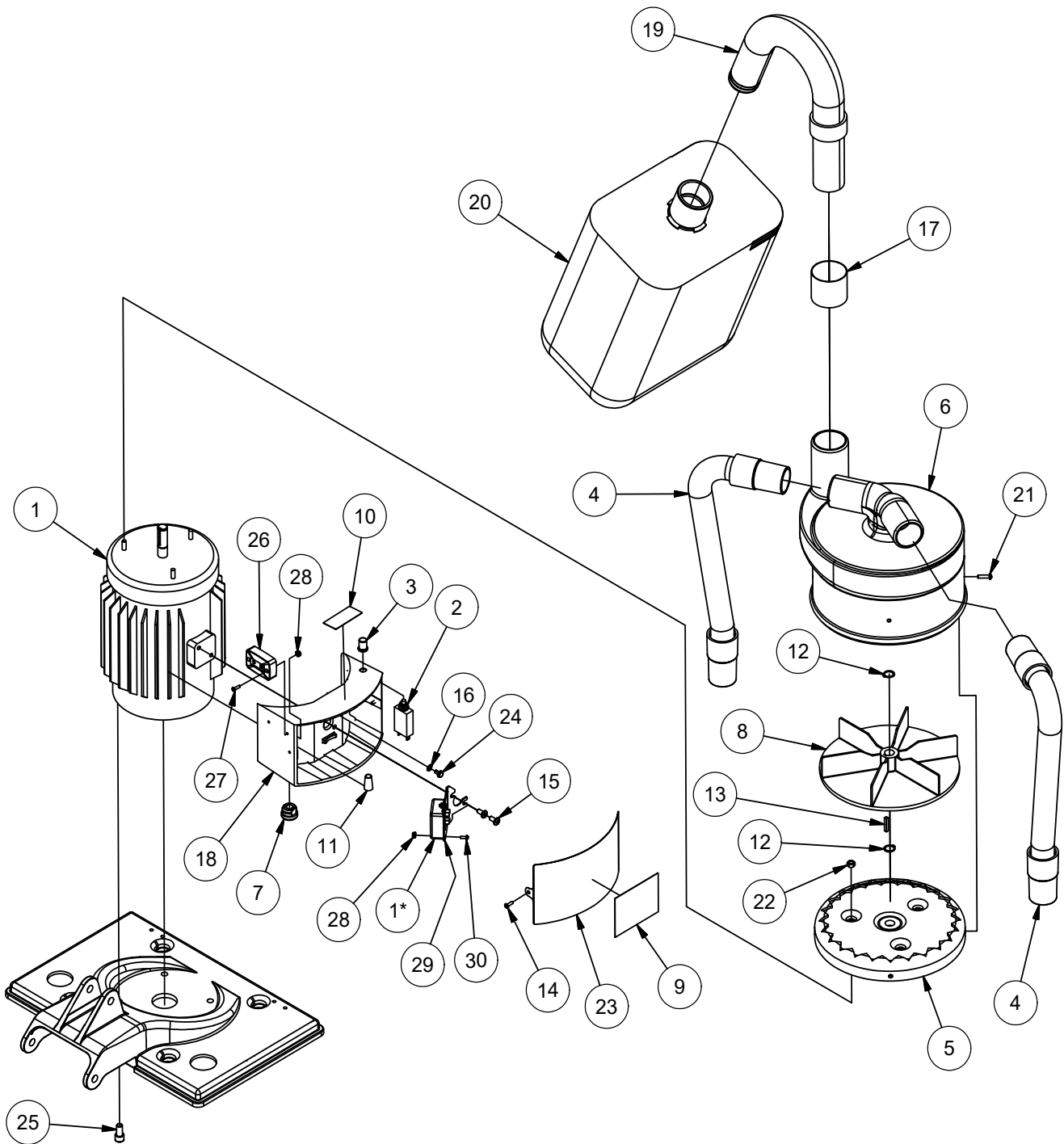

Motor Assembly (continued)

<u>Item</u>	<u>Ref. No.</u>	<u>Description</u>	<u>Qty</u>	<u>Item</u>	<u>Ref. No.</u>	<u>Description</u>	<u>Qty</u>
1A	56382885	MOTOR, 1 HP, 115V, 60HZ	1	11	170667	CONNECTOR, TWIST, WIRE	1
A1	AS018100	STARTER, SWITCH**	1	12	797301	RING, RETAINING, 5/8"	1
A2	41311A	CAPACITOR, RUN**	1	13	915044	KEY, SQUARE, 3/16"	1
A3	41312A	CAPACITOR, START**	1	14	962727	SCREW, #8 X 1/2"	2
A4	50275A	COVER, FAN, MOTOR**	1	15	962823	SCREW, 1/4" X 1/2", BH	2
A5	AS001800	FAN, MOTOR**	1	16	980603	WASHER, #10, LOCK, EXT	1
2A	56454538	CIRCUIT BREAKER, 15A	1	17	56380336	SEAL, PIPE, DUST	1
2B	41419A	CIRCUIT BREAKER, 15A (OLD)	1	18	22906A	ENCLOSURE, MOTOR, START	1
3	56459367	BOOT, RESET BUTTON	1	19	61833A	TUBE, EXHAUST	1
4	30407B	HOSE	1	20	53741A	BAG, DUST	1
5	10478A	COVER, HOUSING, ASM.	1	21	85383A	SCREW, #10 X 3/4"	4
6	35242A	HOUSING, BLOWER	1	22	920208	NUT, HEX, 1/4"	3
7	51523A	BUSHING, RELIEF, STRAIN	1	23	62667A	COVER, ENCLOSURE	1
8	54765A	IMPELLER	2	24	85833A	SCREW, MACHINE, 10-32 TYPE 23	1
9	77195A	LABEL, UI FIRE & SAND	1	25	86112A	SCREW, 3/8-16 X 3/4 SOCKET HD	4
10	77234A	PLATE, WARNING	1	26	AS015300	METER, HOUR, VIBRATION ACTIVATED	1
				27	80310A	SCREW, 6-32 X 1/2, PAN HD PHIL	2
				28	920056	NUT-6X32 ELASTIC STOP	4
				29	AS017502	BRACKET, MOUNTING, START, SWITCH, PLATED	1
				30	85313C	SCREW 6-32 X 3/8 PAN HD	2

(**) = Not Shown

Handle Assembly

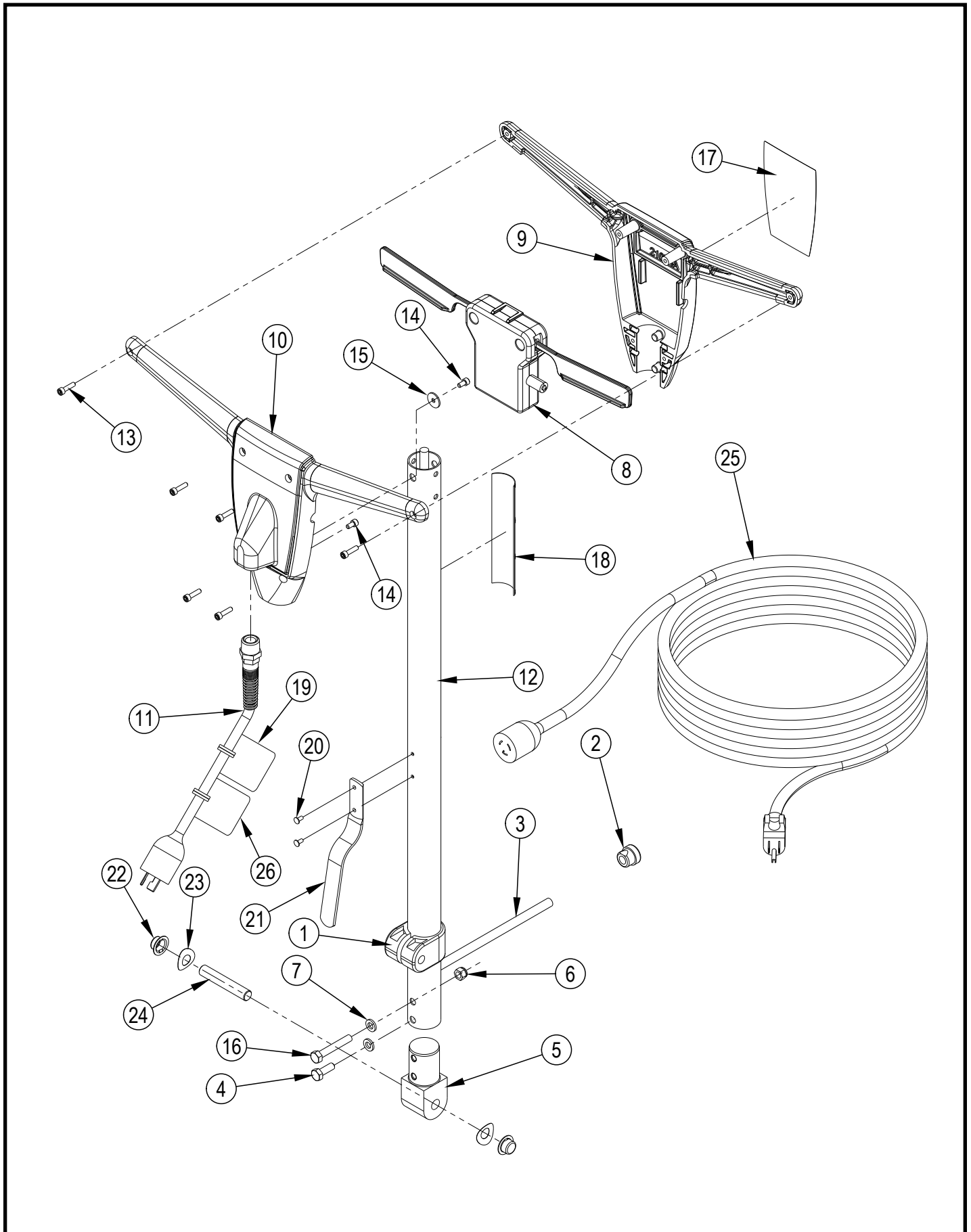

Handle Assembly (continued)

<u>Item</u>	<u>Ref. No.</u>	<u>Description</u>	<u>Qty</u>	<u>Item</u>	<u>Ref. No.</u>	<u>Description</u>	<u>Qty</u>
1	442001	CLAMP, TUBE, HANDLE	1	14	80290A	SCREW, #10 X 3/8"	2
2	627561	RELIEF, STRAIN	1	15	80291A	WASHER, FLAT, #10	1
3	40522A	INTERCONNECT, CORD	1	16	85817A	BOLT, HEX, 5/16" X 2"	1
4	85812A	BOLT, HEX, 5/16" X 7/8"	1	17	71126A	LABLE, HANDLE	1
5	509240	TONGUE, TUBE, HANDLE	1	18	71347A	LABLE, WARNING	1
6	920110	NUT, LOCK, 5/16"	1	19	70175A	TAG, WARNING	1
7	980652	WASHER, LOCK, 5/16"	2	20	930005	RIVET, 5/32"	2
8	10687A	INTERLOCK, ASM	1	21	64325A	HOOK, CORD	1
9	21074A	FRONT, HANDLE	1	22	920346	PALNUT, TYPE W	2
10	21075A	REAR, HANDLE	1	23	80295A	WASHER, BOWED	2
11	40931A	ADAPTER, CORD	1	24	67474A	SHAFT, PIVOT, HANDLE	1
12	61825A	TUBE, HANDLE	1	25	40540A	CORDSET, 12/3 X 40FT	1
13	80284A	SCREW, #10 X 3/4"	6	26	70175A-FR	TAG, WARNING	1

Limited Warranty

OBS-18DC HDTR

TO QUALIFY FOR THIS WARRANTY

- (1) Machine must be registered within 30 days from the time of purchase on a form provided by American Sanders. Your American Sanders Distributor is responsible for the registration of your machine. Please cooperate with your Distributor in supplying necessary information on the card.
- (2) The machine must have been purchased from American Sanders or an authorized American Sanders Distributor.
- (3) This warranty extends to the original purchaser only and is not transferable to subsequent owners.

TIME PERIODS

ONE (1) YEAR WARRANTY - For the OBS-18DC HDTR. Warranted to be free from defects in material and workmanship for a period of one (1) year from the date of purchase by the original owners. (See Exclusions)

EXCLUSIONS (Not Covered by Warranty)

- (1) Expendable wear items and parts that fail through normal wear by reason of their characteristics (cords, pads, grip face, wheels, isolators, filters, bags, or other consumable parts).
- (2) This warranty does not extend to parts affected by misuse, neglect, abuse, accidents, damage in transit, overloading the capacity of the machine, failure due to lack of proper maintenance or care as described in the operating and maintenance instructions. All defective parts must be returned to the distributor for credit.
- (3) Minor adjustments, such as tightening of screws or bolts not connected with the replacement of parts, are not covered.
- (4) Repairs or alterations by an organization other than the factory or an Authorized Service Center are not covered and will void any American Sanders warranty as to the parts or systems repaired or altered by a non-authorized organization.

THE OBLIGATION OF AMERICAN SANDERS

- (1) The obligation of American Sanders under this warranty is limited to repairing or replacing, at its option, any part which is proven to be defective in material or workmanship under normal use for the applicable period stated above.
- (2) Warranty repairs will be made by your American Sanders Distributor without charge for parts and labor. They will be compensated with a warranty labor rate of \$45.00 per hour, for the first year of ownership.
- (3) Parts repaired or replaced under this warranty are warranted only during the balance of the original warranty period. All defective parts replaced under these warranties become the property of American Sanders.

WARRANTY SERVICE

To obtain warranty service, take your machine and proof of purchase to any authorized American Sander Distributor. American Sanders will not reimburse expenses for service calls or travel. For the Distributor in your area, call American Sanders Customer Service Department at 800-367-3550 or 336-372-8080. If you are dissatisfied with the service that you receive, call or write American Sanders Customer Service Department for further assistance.

INSTRUCTIONS AND CONDITIONS FOR WARRANTY REIMBURSEMENT

- Order replacement part: Orders will be processed and charged, as normal procedure.
- Call American Sanders for R/A number.
- You will need the Machine Serial Number and the Machine Model Number.
- Parts must be returned, accompanied with the R/A number to be eligible for warranty credit.
- All Warranty Parts will be shipped prepaid UPS Ground, any other method will be at the recipients expense.
- Freight on any Warranty Part after 30 days must be paid for by the Purchaser.
- Warranty labor rate is \$45.00 USD per hour.
- Credit will be issued upon completion of the above steps, at the above rates.

Transportation of hazardous waste or contaminated equipment is subject to various laws and regulations. In returning machines, parts, or accessories under this limited warranty, the end user must certify in writing that the machines, parts, or accessories being returned have not been used for handling, clean up, or disposal of hazardous waste or hazardous materials including but not limited to such things as asbestos, anthrax etc. or if the machines, parts, or accessories being returned have been used for handling, clean up, or disposal of hazardous waste or hazardous materials, then the end user must have the machines, parts or accessories decontaminated by licensed and qualified decontamination professionals and provide written certification of this decontamination signed by the decontamination professionals. These machines, parts or accessories are to be returned only to the local American Sanders Service Center for warranty service along with decontamination certification.

DISCLAIMER OF CONSEQUENTIAL

THERE ARE NO WARRANTIES THAT EXTEND BEYOND THE DESCRIPTION OF THE LIMITED WARRANTIES STATED WITHIN. NO OTHER WARRANTY, EXPRESSED OR IMPLIED, INCLUDING BUT NOT LIMITED TO ANY IMPLIED WARRANTY OF MERCHANTABILITY OR FITNESS FOR A PARTICULAR PURPOSE, IS MADE EXCEPT AS EXPRESSLY STATED HEREIN. ANY STATUTORY IMPLIED WARRANTIES, INCLUDING ANY WARRANTY OF MERCHANTABILITY OR FITNESS FOR A PARTICULAR PURPOSE, THAT ARE IMPOSED BY LAW DESPITE THE EXPRESS LIMITATION OR WARRANTIES ABOVE, ARE EXPRESSLY LIMITED TO THE DURATION OF THE WRITTEN WARRANTY. BUYER UNDERSTANDS, ACKNOWLEDGES AND AGREES THAT THE REMEDIES PROVIDED UNDER THIS LIMITED WARRANTY ARE THE SOLE AND EXCLUSIVE REMEDIES AVAILABLE TO THE BUYER. AMERICAN SANDERS DISCLAIMS ANY RESPONSIBILITY FOR LOSS OF USER TIME OF THE AMERICAN SANDERS MACHINE OR ANY OTHER INCIDENTAL OR CONSEQUENTIAL DAMAGES. THIS INCLUDES, BUT NOT LIMITED TO INDIRECT, SPECIAL OR CONSEQUENTIAL DAMAGES ARISING OUT OF OR IN CONNECTION WITH THE FURNISHING, PERFORMANCE, USE OF OR INABILITY TO USE THE MACHINE. ANY EXTENSIONS OF OR MODIFICATIONS MADE TO THIS WARRANTY BY A DEALER/DISTRIBUTOR OF AMERICAN SANDERS ARE THE SOLE RESPONSIBILITY OF THE DEALER/DISTRIBUTOR.

American Sanders reserves the right to change its warranty policy without notice.

Copyright 2017 American Sanders



American Sanders

an AMANO Company

1 Eclipse Rd ● PO Box 909
Sparta, North Carolina 28675 ● USA
www.pioneereclipse.com
www.americansanders.com

+1-336-372-8080
1-800-367-3550
Fax 1-336-372-2913