

MPPT Solar Charge Controller

4 STAGE CHARGING

SC420/ND

SC440/ND

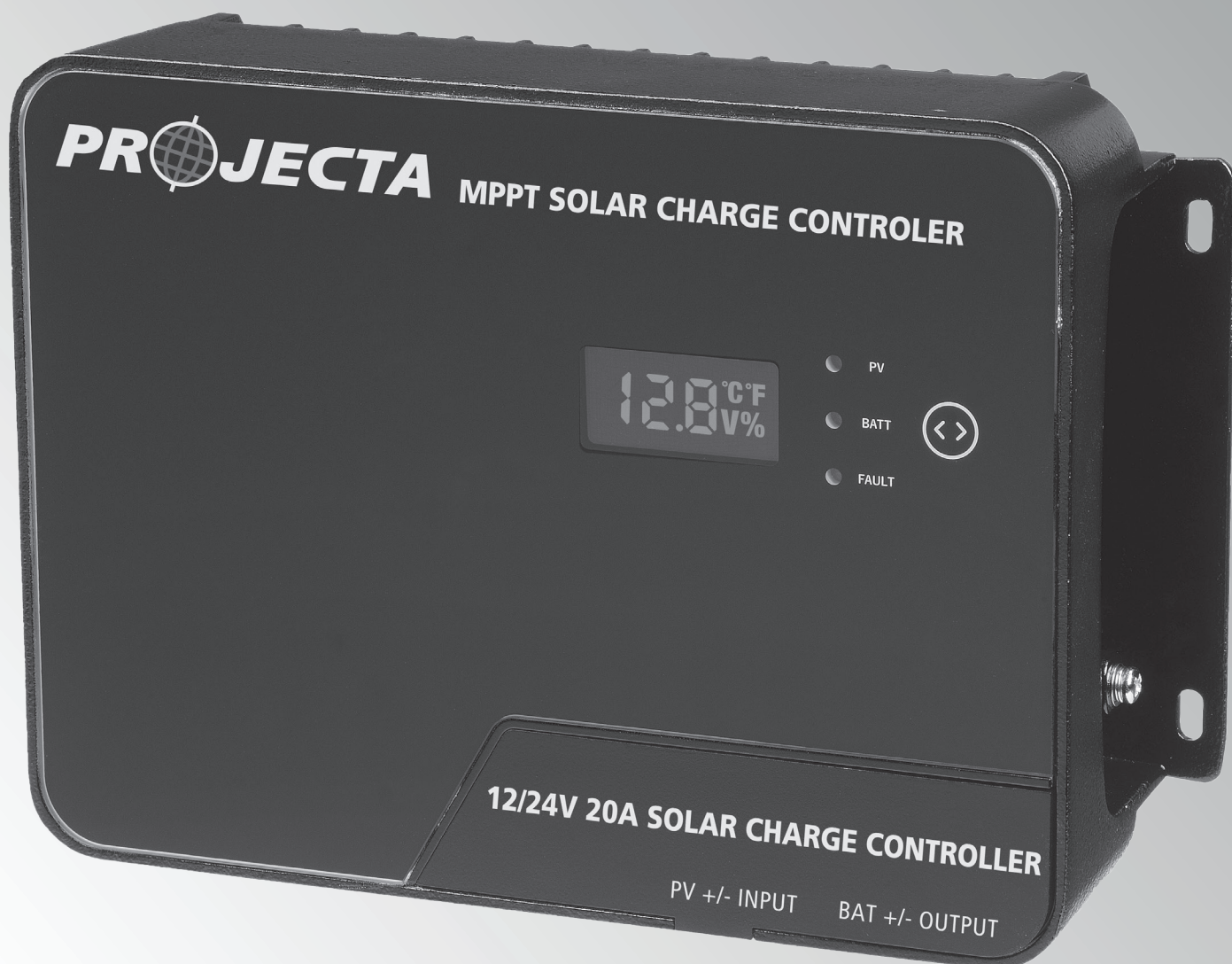

Pictured: SC420



1. Safety Tips

- Please ensure the instructions are read prior to any installation.
- Keep instructions in a safe place for future reference.
- SC420 and SC440 are designed for indoor use only
- Beware of any nearby electrical equipment that may interfere with installing this device. Do not connect any AC sources to the controller as it may cause a fire/explosion and will permanently damage the device.
- Always check the battery polarities before making a connection. The positive terminal of a battery goes into BAT+ and the negative into BAT-.
- The controller is not designed to run without a battery voltage reference. In the event of replacing servicing the battery, always disconnect the solar input first (or fully cover the panels), then replace/ service the battery.
- Solar panels can generate high voltages and currents, make sure your solar panels are completely covered from sunlight during installation.
- Keep this product out of reach of children.
- Always install a fuse on both the input positive and output positive circuit.
- Connecting wires to this device can generate sparks, please wear proper insulation gear while installing this device.
- This controller is a negative grounded (positive switching) type.
- Always take the total length of wire into consideration and use the correct wire size, see below for a table of recommended wire size for various current loads.
- Lead acid batteries can be dangerous. Ensure no sparks or flames are present when working near batteries.

Solar Input Current	5A	10A	20A	30A	40A
Wire Cross Section Area (mm ²)	1.5	2.5	5	8	10
Wire AWG	15	13	10	8	7

2. Product Features

- 4 Stage charging ensures the battery is charged to the optimum level
- Advanced MPPT technology to improve charging efficiency in different weather and temperature conditions
- Tempered glass cover with screen touch operation and sturdy aluminium housing
- Selectable battery chemistry types, including AGM, GEL, WET and Lithium
- Auto recognition of 12V/24V battery system voltage
- Protects your battery from discharge at night. Under low light or no light conditions, the solar panel voltage could be less than the battery voltage. The controller contains circuitry which prevents current flowing back from the battery and into the solar panel
- Multi charging protections against reverse polarity, over-voltage and over-temperature.
- With the use of a battery temperature sensor (optional), the controller will compensate charging voltages when the battery temperature becomes too high (For Lead acid only).
- Supports remote display for monitoring additional parameters, such as charging watt-hours, charging current and solar input voltage.

3. Device Diagram

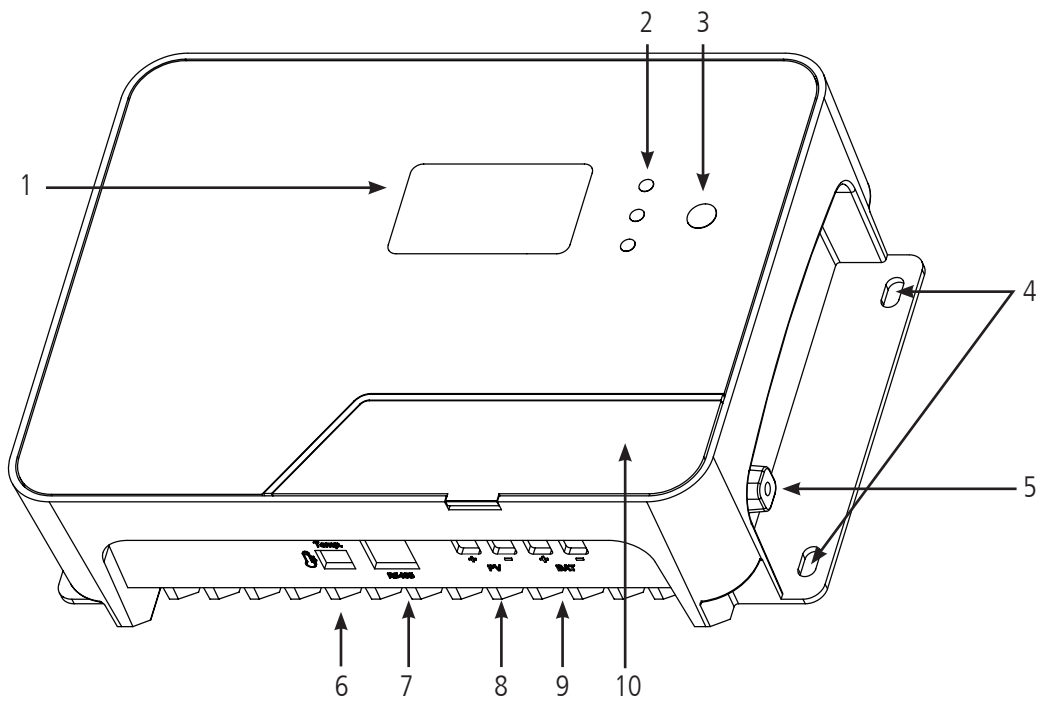

#	Description	#	Description
1	LCD Display Screen	6	External Temperature Sensor Port
2	LED Indicator (PV, BAT, FAULT)	7	RS485 Communication Port
3	Touch Screen Button	8	Solar Input Terminals
4	Installation Mounting Holes	9	Battery Terminals
5	Grounding Terminal	10	Magnetic Cover

4. Wiring Instructions

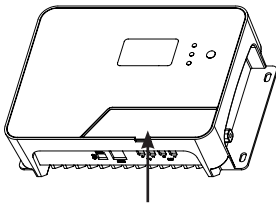

1 & 2: Remove the magnetic cover, and put it aside

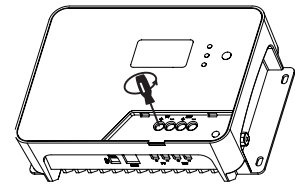
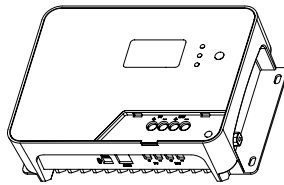

3. Unscrew the terminals completely, before inserting any wiring leads.

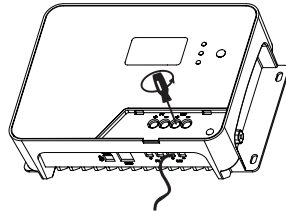

4. Insert the bare wire side of the cable to the terminal, and tighten the screws.

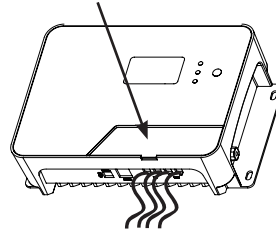

5. Check the wiring condition and put the magnetic cover back.

5. Wiring Sequence

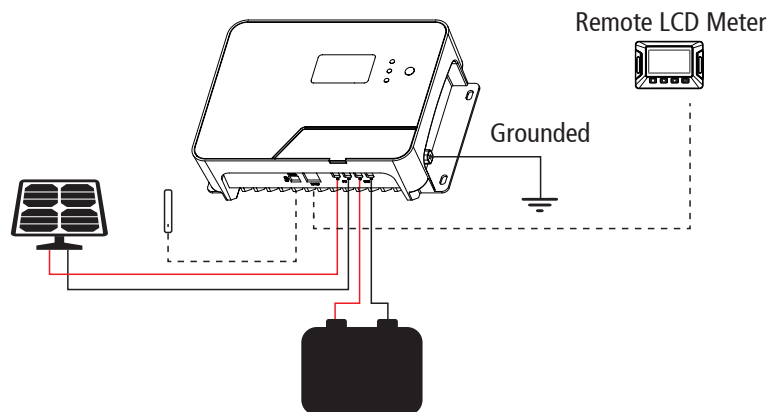

1. Connect the positive battery wire followed by the negative battery wire.
2. Connect the positive solar array input wire followed by the negative solar array input wire (make sure your solar panels are fully covered to prevent electrical shock)
3. Connect the external temperature sensor (optional) to its terminal shown above, and place the sensor on the side of a battery.
4. Connect the external remote LCD through RS485 communication port (if applicable)

The controller is not designed to run without a battery voltage reference. In the event of replacing/servicing the battery, always disconnect the solar input or fully cover the panels, then remove/replace the battery.

6. Operation

6.1 Voltage auto-recognition

System startup: When the battery is connected, the system will automatically recognise the system voltage and briefly display this on the LCD display.

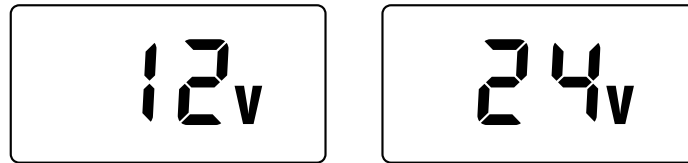

6.2 LCD Display Cycle

Short press the touch screen button will cycle through the following four displays:

- Battery Voltage
- Battery SOC
- Temperature
- Error Code

To adjust the temperature scale (From °C to °F and vice-versa):

1. While the display is showing the temperature, long press the touch screen button to enter Set mode.
2. Short press the button to select the scale.
3. Long press again to exit and save the settings.

6.3 Charging Stages

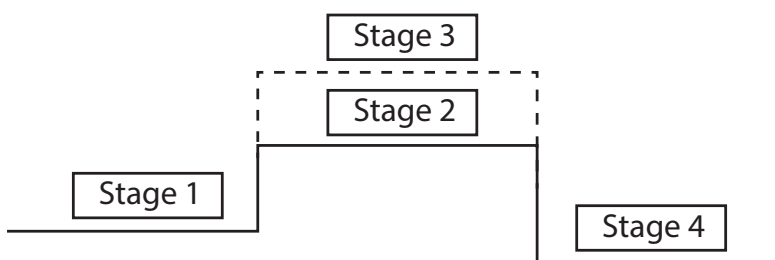

Bulk Charge (Stage 1) - Utilising MPPT technology, the controller will deliver maximum current until batteries rise to boost level.

Boost Charge (Stage 2) - Once the battery is almost charged, voltage is held constant for 2 hours.

Equalization Charge* (Stage 3) - Only applicable to Flooded/WET and AGM mode. Every 30 days, it will skip boost and automatically run equalization to rejuvenate the internal battery cells.

Float Charge (Stage 4) - Only applicable to non-lithium batteries. When the battery is fully charged, it will reduce the voltage to 13.8V to keep the battery topped up.

6.4 LED Indication Chart

LED Name	LED Display	Signal Indication
PV	Off	Not In Charge
	Steady On	In Charge
BAT	Fast Flash	Battery Over Voltage
	Steady On	Battery On & Normal
FAULT	Off	No Error or Alarm
	Steady On	System with Error or Alarm

7. Parameters Setting

7.1 Selecting Battery Type

To select the battery type, long press the touch button while the display is not showing the temperature. This will enter the battery set mode.

Short press while in this mode will cycle through the following chemistries:

GEL (default) - For Gel type batteries

L12 - For Lithium 12V batteries

L24 - For Lithium 24V batteries

FLD - For WET/Flooded batteries

SEL - For Sealed Lead-acid/AGM batteries

To exit and save the setting, long press the touch button.

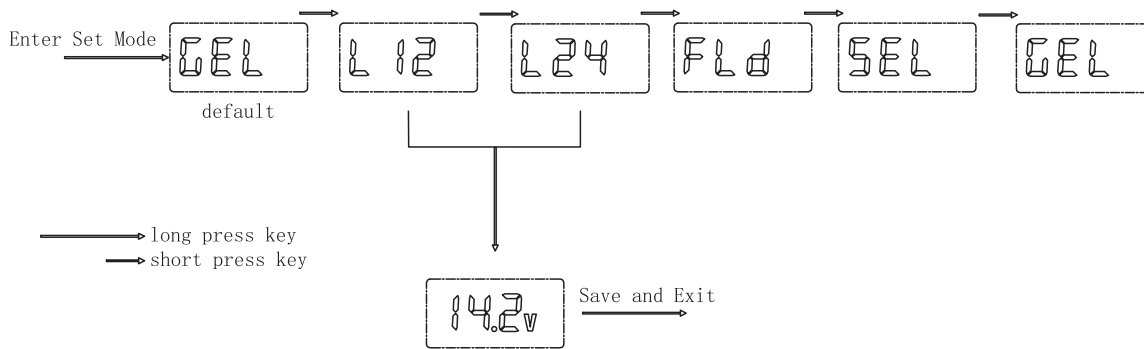

7.2 Touching Button Chart

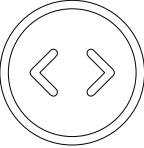
Key	System Mode	Operation	Operation Description
	View Mode	Short Press	View Next Page
		Long Press	Enter SET mode
	Set Mode	Short Press	Select battery type or temperature scale
		Long Press	Exit SET Mode & save the settings

8. Error Code Chart

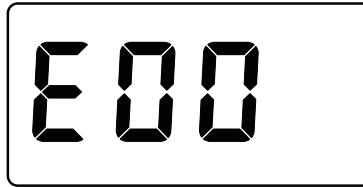

CODE	Error	Description	Quick Troubleshoot
E00	No Error	-	-
E02	Battery Over-voltage	Battery output voltage has exceeded the controller's maximum rating	Check whether there is an external voltage applied to the battery
E06	Controller Over-temperature	Controller has exceeded the ambient temperature limit	Ensure the controller is placed in a well-ventilated area.
E07	Battery Sensor Over-temperature	The surrounding temperature around the temperature sensor is too high	Check the sensor is not near a hot source. Battery may be faulty if it is too hot
E10	Solar Over-voltage	Solar input voltage has exceeded the controller's maximum rating	Lower the solar panel's total voltage connected to the controller
E13	Solar Reverse Polarity	Solar input cables are connected in reverse	Disconnect and reconnect with the correct polarity
E14	Battery Reverse Polarity	Battery output cables are connected in reverse	Disconnect and re-connect with correct wire polarity

8.2 Battery Temperature Sensor:

As an option, the unit provides a port to connect the external battery temperature sensor. If it is used, the unit will optimise the charging performance subjected to the battery temperature

9. Controller Specification

Controller Parameter		Specifications			
Model No.	SC420/SC420-ND	SC440/SC440-ND			
System Wiring Grounded	Negative Grounded				
Battery System Voltage	12V/24V Auto (FLD/GEL/SEL/USER) Manual (Li/User)		12V/24V Auto (FLD/GEL/SEL/USER) Manual (Li/User)		
No-load Loss	12mA/12V; 10mA/24V		12mA/12V;10mA/24V		
Max Solar Input Voltage	<100Voc		<100Voc		
Rated Solar Charge Current	20A		40A		
Max Solar Input Power	300W/12V 600W/24V		600W/12V 1200W/24V		
Operating Temperature	-35°C ~ +45°C				
Net Weight	1.2kg		1.9kg		
Communication	RS485				
Controller Dimensions	190*120*59mm		218*150*65mm		
Battery Voltages		Battery Parameters			
Battery Types	FLD	SEL	GEL (default)	USER (applicable only with SC400D Remote display)	LI
Equalization Charge Voltage	14.8V / 29.6V	14.6V / 29.2V	-	Default	-
Boost Charge Voltage	14.6V / 29.2V	14.4V / 28.8V	14.2V / 28.4V	Default: GEL	14.2V / 28.4V
Float Charge Voltage	13.8V / 27.6V			Default: GEL	-
Boost Charge Recovery Voltage*	13.2V / 26.4V			Default: GEL	-
Auto Temperature Compensation	-3mV/2V/°C			Default: GEL	-
Accessory List		Package Status			
External Temperature Sensor	Yes				
Remote LCD Meter	Optional				

*When the battery voltage drops below 13.2V (26.4V for 24V systems), it will perform a normal charge cycle.

10. Controller Dimensions

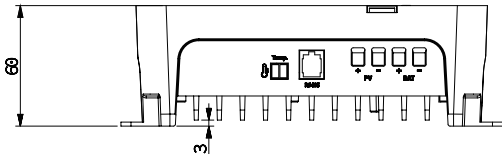

SC420, SC420-ND
 Product Dimensions: 190*125*60mm
 Installation Area Dimensions: 180*80mm
 Installation Hole Size: 5*5mm
 Connection Socket Size: 7.5*7.5mm

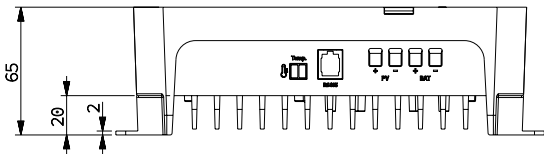
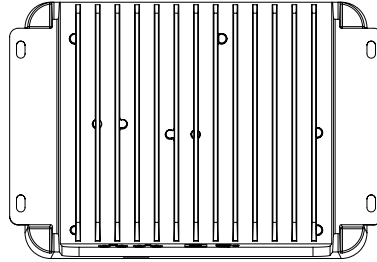
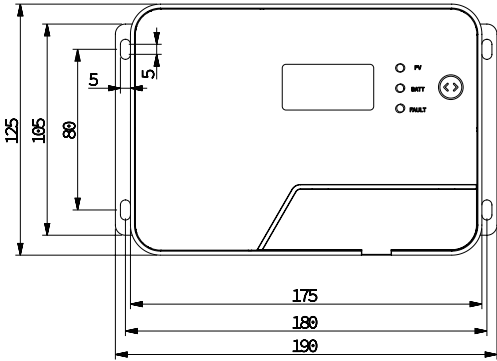

SC440, SC440-ND
 Product Dimensions: 218*150*65mm
 Installation Area Dimensions: 205*60mm
 Installation Hole Size: 5*5mm
 Connection Socket Size: 7.5*7.5mm

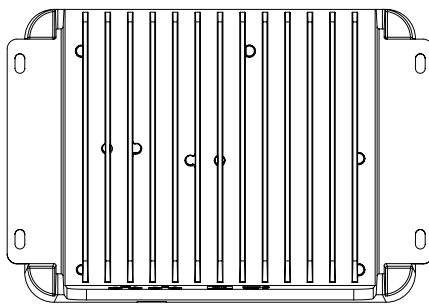
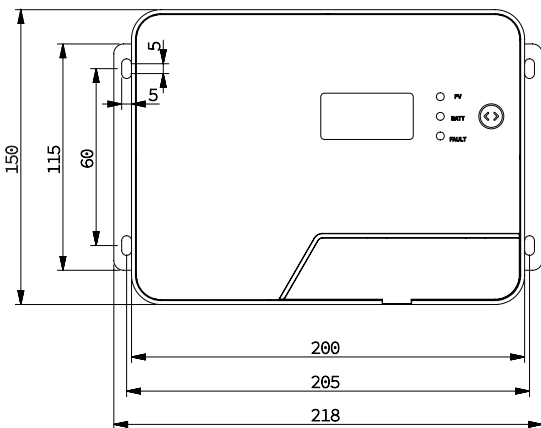

WARRANTY STATEMENT

Brown & Watson International Pty Ltd ("BWI") of 1500 Ferntree Gully Road, Knoxfield, Vic., telephone (03) 9730 6000, fax (03) 9730 6050, warrants that all products described in its current catalogue will under normal use and service be free of failures in material and workmanship for a period of three (3) years from the date of the original purchase by the customer as marked on the invoice. This warranty does not cover ordinary wear and tear, abuse, alteration of products or damage caused by the purchaser.

To make a warranty claim the consumer must deliver the product at their cost to the original place of purchase or to any other place which may be nominated by either BWI or the retailer from where the product was bought in order that the warranty assessment may be performed. The consumer must also deliver the original invoice evidencing the date and place of purchase together with an explanation in writing as to the nature of the claim.

In the event that the claim is determined to be for a minor failure of the product then BWI reserves the right to repair or replace it at its discretion. In the event that a major failure is determined the consumer will be entitled to a replacement or a refund as well as compensation for any other reasonably foreseeable loss or damage.

This warranty is in addition to any other rights or remedies that the consumer may have under State or Federal legislation.

IMPORTANT NOTE

Our goods come with guarantees that cannot be excluded under the Australian Consumer Law. You are entitled to a replacement or refund for a major failure and compensation for any other reasonably foreseeable loss or damage. You are also entitled to have the goods repaired or replaced if the goods fail to be of acceptable quality and the failure does not amount to a major failure.

Distributed by

AUSTRALIA

Brown & Watson International Pty. Ltd.

Knoxfield Victoria 3180

Phone: (03) 9730 6000

Fax: (03) 9730 6050

National Toll Free: 1800 113 443

NEW ZEALAND OFFICE

Griffiths Equipment Ltd.

19 Bell Avenue,

Mount Wellington,

Auckland 1060, New Zealand

Phone: (09) 525 4575

Fax: (09) 579 1192