



MX8500SD

Safety Instructions & Operator's Manual



SAFETY INSTRUCTIONS AND WARNINGS

⚠ DANGER		
<p>Using a generator indoors CAN KILL YOU IN MINUTES.</p> <p>Generator exhaust fumes contains carbon monoxide.</p> <p>This is a poison you cannot see or smell.</p> <p>Avoid other generator hazards. READ MANUAL BEFORE USE.</p>	 <p>NEVER use inside a home or garage, EVEN IF doors and windows are open.</p>	 <p>Only use OUTSIDE and far away from windows, doors and vents.</p>

INTRODUCTION

This Operating Manual has been designed to instruct you on the correct operation of your generator, Your satisfaction with this product and its safe operation is our ultimate concern. Therefore please take the time to read the entire manual, especially the Safety Precautions. They will help you to avoid potential hazards that may exist when working with this product.

⚠ Read this manual carefully before operating this generator. This manual should stay with this generator if it is sold.

TABLE OF CONTENTS

Introduction	1
Safety Information	3
Generator Safety Warnings	4
Know Your Generator	7
Generator Preparation	12
Grounding The Generator	16
Starting the Generator	17
Shutting off the Generator	20
Maintenance	21
Transportation & Storage	26
Troubleshooting Guide	27
Warranty Information	28

KEY SPECIFICATIONS

Model NO.	MX8500SD
Starting Wattage	7000W
Running Wattage	6500W
Phase	Single
Frequency	50Hz
Voltage	AC 240V
Amperage	27.1A
Engine Type	4-stroke, single cylinder with forced air cooling system
Engine Displacement	531cc
Fuel Tank Capacity	18L
Oil Capacity	1.65 L

SAFETY INFORMATION

 **WARNING:** Before operating the generator, make sure to read all safety warnings and all instructions. Failure to follow the warnings and instructions may result in electric shock, fire or serious injury.

SAFETY INTRODUCTION

Safety is a combination of common sense, staying alert, and knowing how your tool works. This manual contains important information regarding the generator's potential safety concerns, as well as preparation, operation, and maintenance instructions. Before operating this generator, be sure to read and observe all warnings and instructions both on the generator labels and in this instruction manual. Failure to follow all instructions listed below may result in personal injury.

NOTE: The following safety information is not meant to cover all possible conditions and situations that may occur. We reserves the right to change this product and specifications at any time without prior notice.

SAVE THESE INSTRUCTIONS - Please keep this manual available to all users during the entire life of the tool. Review it frequently to maximize safety for both yourself and others.

SAFETY SYMBOLS

The purpose of following safety symbols is to attract your attention to possible dangers. The safety symbols, and their explanations, deserve your careful attention and understanding. The safety warnings do not by themselves eliminate any danger. The instructions or warnings they give are not substitutes for proper accident prevention measures.

 **DANGER:** indicates a hazard, which, if not avoided, will result in death or serious injury.

 **WARNING:** indicates a hazard, which, if not avoided, could result in death or serious injury.

 **CAUTION:** indicates a hazard, which, if not avoided, might result in minor or moderate injury.

CAUTION: when used without the alert symbol, indicates a situation that could result in damage to the machine.

GENERATOR SAFETY WARNINGS

DANGER: CARBON MONOXIDE

Using a generator indoors **CAN KILL YOU IN MINUTES**. Generator exhaust fumes contains carbon monoxide (CO). This is a poison gas you cannot see or smell. If you can smell the generator exhaust, you are breathing CO. But even if you cannot smell the exhaust fumes, you could be breathing CO.



NEVER use a generator inside homes, garages, crawl spaces, or other partially enclosed areas. Deadly levels of carbon monoxide can build up in these areas. Using a fan or opening windows and doors does NOT supply enough fresh air. ONLY use a generator OUTSIDE and far away from windows, doors, and vents. These openings can pull in generator exhaust fumes.

Even if you use a generator correctly, CO may leak into the home. ALWAYS use a battery-powered or battery-backup CO alarm in the home. If you start to feel sick, dizzy, or weak after the generator has been running, move to fresh air RIGHT AWAY. See a doctor. You may have carbon monoxide poisoning.

- Do not operate near open flame, heat, or any other ignition source. Do not smoke near generator.
- Always operate on a firm, level surface.
- Always turn generator off before refueling. Allow generator to cool for at least 2 minutes before removing fuel cap. Loosen cap slowly to relieve pressure in tank.
- Do not overfill fuel tank. Diesel may expand during operation. Do not fill to the top of the tank. Allow for expansion. Always check for spilled fuel before operating.
- If fuel spills, move the generator at least 9M away from the spill and wipe clean any spilled fuel before starting the engine.
- Empty fuel tank before storing or transporting the generator.

 **WARNING:** If this generator is used as a supply for a BUILDING'S WIRING SYSTEM, the generator MUST be installed by a qualified electrician and connected to a transfer switch as a separately derived system in accordance with all applicable laws and electrical codes and the National Electrical Code. The generator shall be connected to a transfer switch that switches all conductors excluding the equipment grounding conductor. The frame of the generator shall be connected to an approved grounding electrode.

GENERATOR SAFETY WARNINGS

 **WARNING:** Do not let comfort or familiarity with the product replace strict adherence to product safety rules. Failure to follow the safety instructions may result in serious personal injury.

OPERATING ENVIRONMENT

1. Using a generator indoors can kill you in minutes. Only use a generator OUTSIDE and far away from windows, doors and vents.
2. Do not smoke near the generator.
3. Do not operate near open flame, heat, or flammable materials. This generator may emit highly flammable and explosive petrol vapors, which can cause severe burns or even death if ignited. A nearby open flame can lead to an explosion even if it isn't directly in contact with petrol.
4. Do not expose the generator to rainy or wet conditions; doing so significantly increases the risk of electrical shock. Never handle the generator, electronic devices, or any cord while standing in water, while bare-foot, or when hands or feet are wet.
5. Always operate the generator on a dry, firm, level surface.
6. The generator should have at least 1.5M of clearance from buildings or other equipment during operation.
7. Do not allow children or non-qualified persons to operate the generator.

GENERATOR PREPARATION

1. Always ground the generator before using it to maximize safety (see "GROUND THE GENERATOR" section.)
2. Do not overfill fuel tank, as **diesel** may expand during operation. Do not fill to the very top of the tank. Leave room for expansion. Always check for spilled fuel before operating.
3. If any part of the generator, electrical device or power cord is broken, damaged, or defective, make sure it is repaired or replaced before operation. Service should only be performed by a qualified technician. Do not use receptacles or cords that show signs of damage, such as broken or cracked insulation.
4. If connecting the generator to a building's electrical system for standby power, you **MUST** consult a qualified electrician and install a transfer switch. Such connections must comply with local electrical laws and codes. Failure to comply can create a back-feed, which may result in serious injury or death to utility workers.
5. Never modify the generator in any way. Modifying or using the machine for any other purpose for which it is not designed may result in serious injuries, machine damage and voiding of the warranty

GENERATOR SAFETY WARNINGS

GENERATOR OPERATION

1. Only use the generator for its intended purposes. Modifying or using the generator for operations for which it was not designed may cause hazards and personal injury.
2. Do not touch bare wires or receptacles (outlets).
3. Do not exceed the wattage capacity of the generator by plugging in more electrical devices than the unit can handle. This could damage the generator and/or connected electrical devices. Check the operating voltage and frequency requirements of all electrical devices prior to plugging them into the generator.
4. Allow generator to run for several minutes before connecting electrical devices. Do not start or stop engine with electrical devices plugged in to the receptacles. Failure to do so could damage the generator and / or connected electrical devices.
5. Do not turn ON electrical devices until after they are connected to the generator.
6. Generators vibrate in normal use. During and after the use of the generator, inspect both the generator as well as extension and power supply cords for damage resulting from vibration.
7. Do not touch HOT PARTS. This generator produces heat when running. Temperatures near exhaust can exceed 65°C. Allow generator to cool down after use before touching engine or areas of the generator that become hot during use.
8. Turn off all connected electrical devices before stopping the generator.
9. Always turn generator off before refueling. Allow generator to cool for at least 2 minutes before removing fuel cap. Loosen cap slowly to relieve pressure in tank.
10. Turn the engine switch to “OFF” position when the engine is not running.
11. Empty fuel tank before storing or transporting the generator. Do not store generator or petrol near furnaces, water heaters, or any other appliances that produce heat or have automatic ignitions. Store the generator and fuel away from sparks, open flames, pilot lights, heat and other sources of ignition.
12. Always wash hands after handling generator.

CAUTION: Misuse of this generator can damage it or shorten its lifespan.

TO MAXIMIZE THE LIFESPAN OF YOUR GENERATOR:

We recommend running your generator at least once a month for 20 to 30 minutes. Start the generator according to the instructions and plug a small load in to make sure the outlet is producing electricity.

KNOW YOUR GENERATOR

GENERATOR

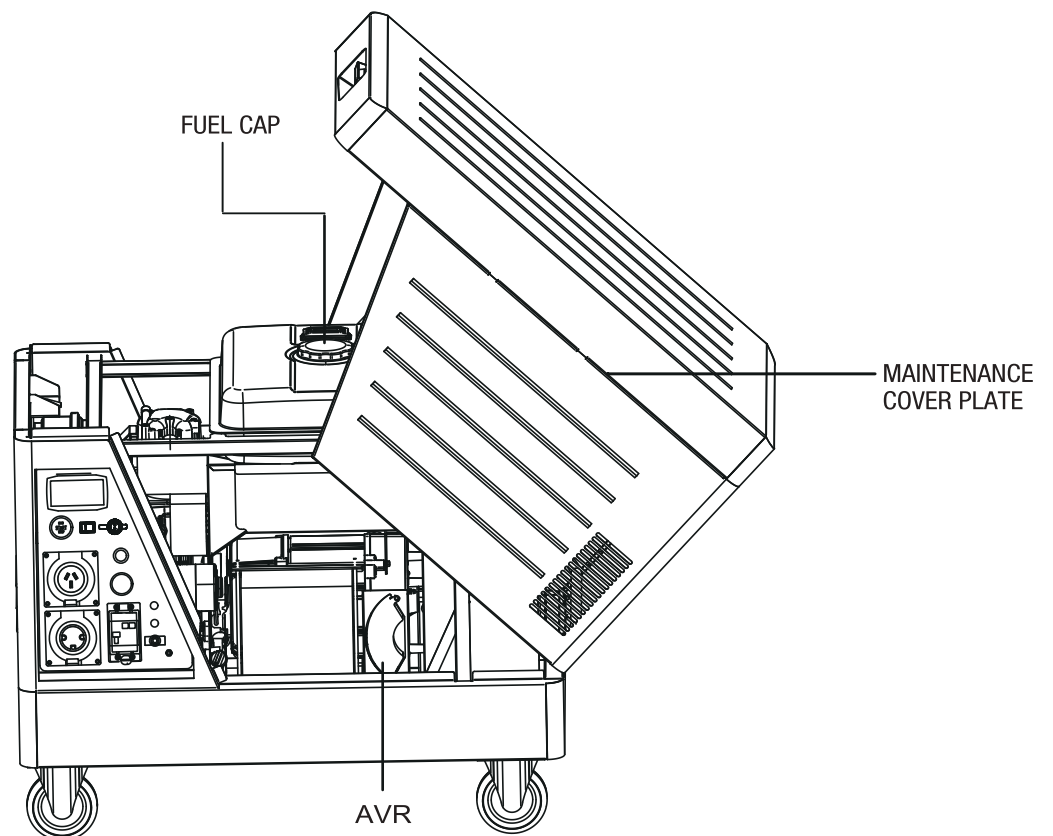
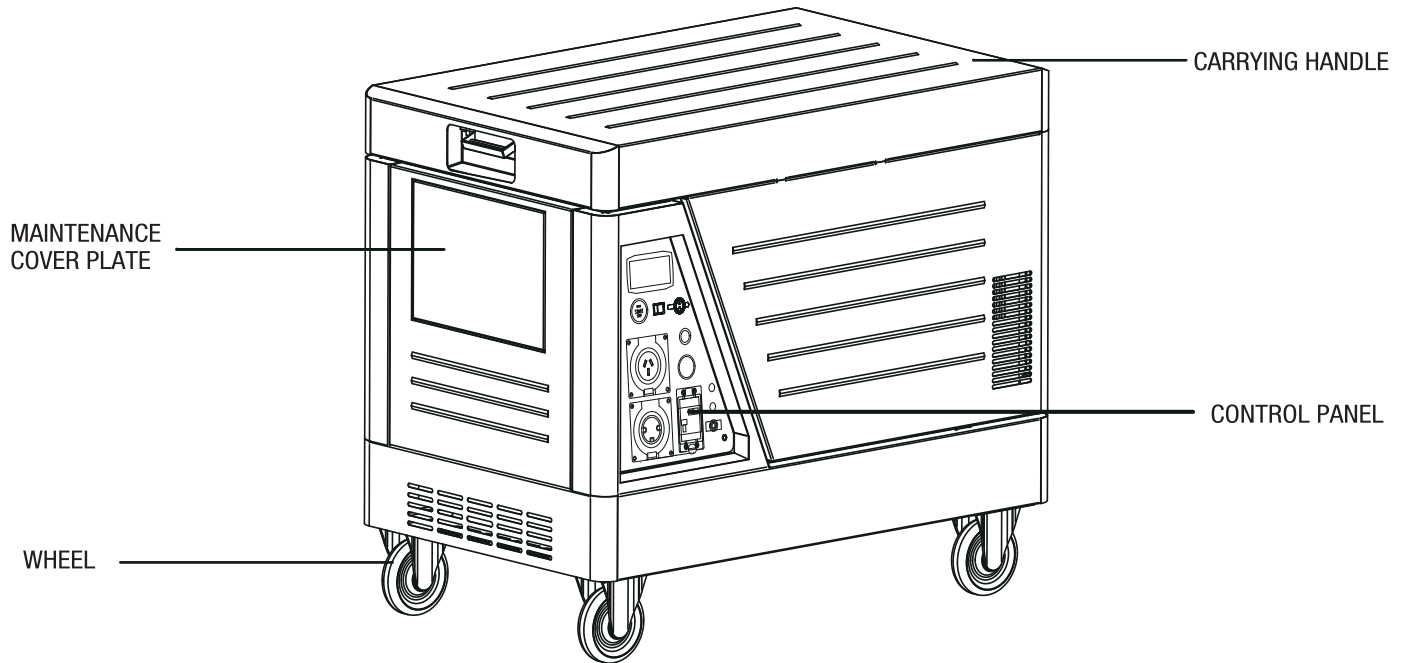

KNOW YOUR GENERATOR

CONTROL PANEL

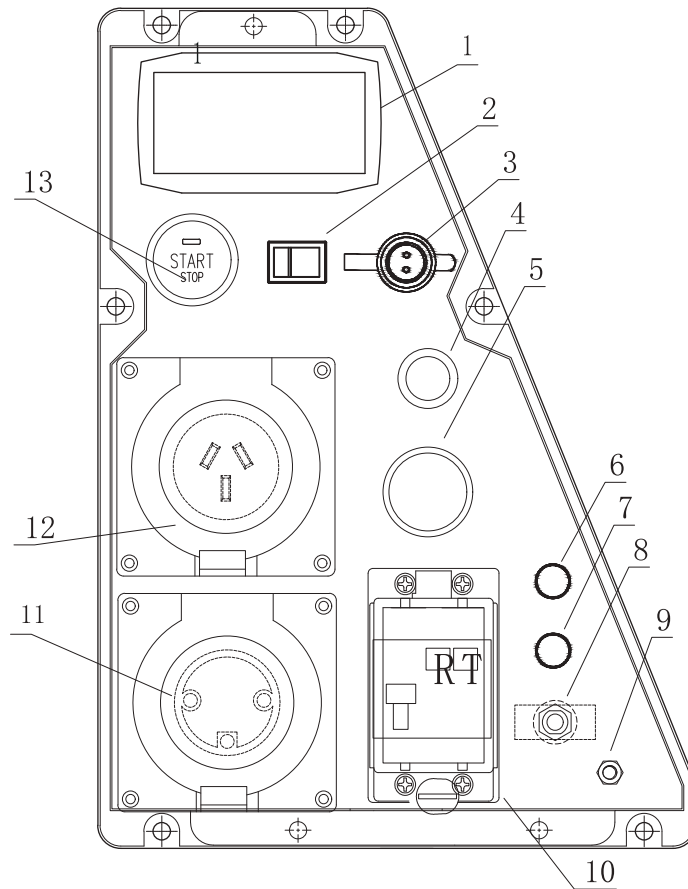

1.DATA CENTER

2.WIRE START SWITCH,CONTROL

3.TWO WIRE START CONNECTOR

4.AIR HEATING SWITCH

5.EMERGENCY STOP

6.POWER INDICATOR LIGHT

7.OIL WARNING LIGHT

8.CIRCUIT PROTECTOR 15A

9.GROUNDING NUT

10.CIRCUIT BREAKER 32A

11.AC 240V SOCKET

12.AC 240V SOCKET

13.ONE-BUTTON START

KNOW YOUR GENERATOR

CIRCUIT BREAKERS

The circuit breakers protect the individual AC and DC circuits. The AC circuit breaker will activate when the AC outlets exceed. The DC circuit breaker will activate when the DC 12V outlets exceed. When the circuit breaker activates, turn off and disconnect the device from its respective outlet, and press the circuit breaker to reset.

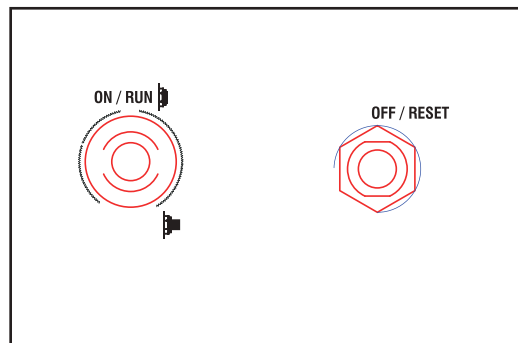

CONNECTING ELECTRICAL DEVICES

CAUTION: Before connecting devices, become familiar with the markings on the control panel before connecting electrical devices.

Follow the steps below to properly connect your device(s) to the generator:

1. Before connecting electrical devices, allow the generator to run for a few minutes to stabilize the speed and voltage output.
2. Select the device with the highest wattage, and make sure it is turned off. Plug the device into the generator and then turn the device on. Allow the engine to stabilize.
3. Repeat step 2 to plug in each additional device. DO NOT attempt to plug in or start multiple devices at the same time.

KNOW YOUR GENERATOR

GENERATOR CAPACITY

Make sure the generator can supply enough running (rated) and starting (max.) watts for the items you will power at the same time. Follow these simple steps.

1. Select the items you will power at the same time.
2. Total the running (rated) watts of these items. This is the amount of power the generator must produce to keep the items running.
3. Estimate how many starting (max.) watts you will need. Starting wattage is the short burst of power needed to start electric motor-driven tools or appliances such as a circular saw or refrigerator. Because not all motors start at the same time, total starting (max.) watts can be estimated by adding only the item(s) with the highest additional starting (max.) to the total rated watts.

Example:

Tool or Appliance	Running Watts*	Additional Starting Watts*
Refrigerator	700	1350
Portable Fan	40	120
Laptop	250	250
46 in. Flat Panel Television	190	190
Light (75 Watts)	75	75
	1255 Total Running Watts	1350 Highest Starting Watts

Total Running Watts	1255
Highest Starting Watts	+ 1350
Total Starting Watts Needed	2605

To prolong the life of the generator and attached devices, it is important to take care when adding electrical loads to the generator. There should be nothing connected to the generator outlets before starting its engine. The correct and safe way to manage generator power is to sequentially add loads as follows:

1. With nothing connected to the generator, start the engine as described later in this manual.
2. Plug in and turn on the first load, preferably the largest load you have.
3. Permit the generator output to stabilize (engine runs smoothly and attached device operates properly).
4. Plug in and turn on the next load.
5. Again, permit the generator to stabilize.
6. Repeat steps 4 and 5 for each additional load.

Never add more loads than the generator capacity. Take special care to consider surge loads in generator capacity as previously described.

NOTICE:

Do not overload the generator's capacity. Exceeding the generator's wattage/ampere capacity may damage the generator and/or electrical devices connected to it.

KNOW YOUR GENERATOR

The chart below serves as a reference for the estimated wattage requirements of common electrical devices. However, do not solely rely on this chart - all electronics and appliances are built differently. Always check the wattage listed on the electrical device before consulting this chart.

Tool or Appliance	Rated (Running) Watts	Surge (Starting) Watts
Hot plate	2500	0
Electric stove (each element)	1500-2800	0
Saw - circular	1500	1500
Window air conditioner	1200	1800
Saw - miter	1200	1200
Microwave	1000	0
Well water pump	1000	1000
Sump pump	800	1200
Refrigerator freezer	800	1200
Furnace blower	800	1300
Computer	800	0
Electric drill	600	900
Television	500	0
Stereo	400	0
Box fan	300	600
Security system	180	0
Common light bulb	75	0

GENERATOR PREPARATION

The following section describes the necessary steps to prepare the generator for use. Failure to perform these steps properly can damage the generator or shorten its life.

STEP 1 - ADD/CHECK OIL

The generator is shipped without oil. User must add the proper amount of oil before operating the generator for the first time. The oil capacity of the engine crankcase is **1.65 L**.

To add oil, follow these steps:

1. Place the generator on a level surface. Make sure the engine is OFF before adding or checking oil.

CAUTION: Keep the generator level! Tilting the generator to assist in filling will cause oil to flow into the wrong areas of the engine and cause damage.

2. Unscrew the oil access cover knob, and remove the cover from the side panel. Unscrew the oil dipstick from the engine.

3. Using an oil funnel or appropriate dispenser, slowly add oil into the oil fill, being careful not to overfill the unit. Fill the crankcase to the upper fill line so you can visually see the oil coming halfway up the oil fill threads.

4. Reinstall the oil dipstick and firmly tighten it. Wipe clean any spilled oil.

5. Reinstall the oil access cover. Turn the oil access cover knob to the locked position to secure the cover in place.

NOTE: Used engine oil should be disposed of at an approved disposal site. See local retailer for more information.

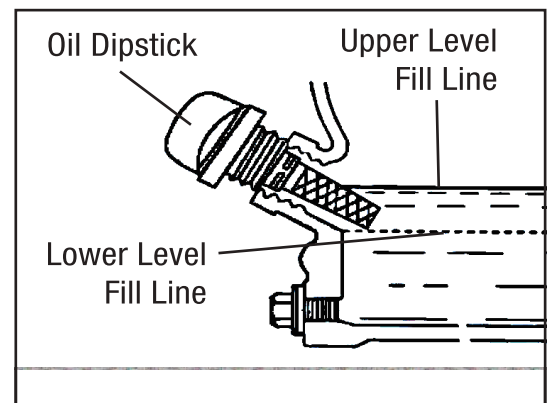
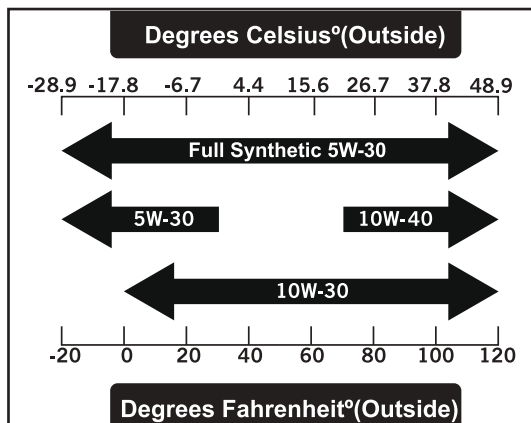
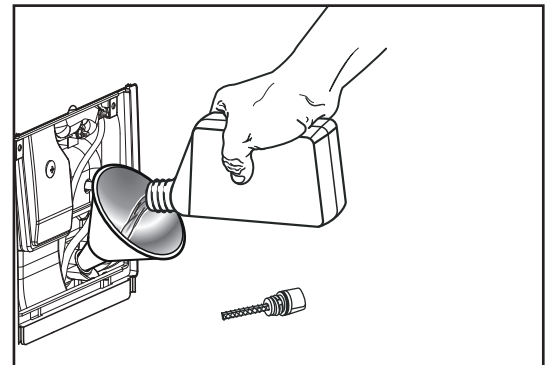
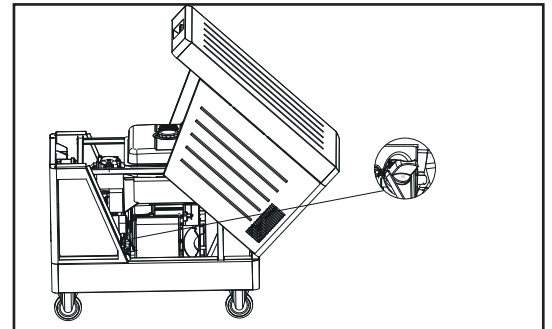

For subsequent operation, the oil level should be checked before each use, or after every 8 hours of operation. The generator is equipped with a low-oil sensor and will NOT start without a sufficient amount of oil.

GENERATOR PREPARATION

To check oil level (before every subsequent start):

Place the generator on a level surface. Make sure the engine is OFF before adding or checking oil.

1. Open the oil access cover. Remove and wipe the dipstick with a clean rag.
2. Insert the dipstick into the oil fill without screwing it in. Remove the dipstick to check the oil mark.

If the oil mark covers less than one half of the dipstick, slowly add oil until the oil mark reaches to the top of the dipstick (or when you can see the oil coming halfway up the oil fill threads).

3. Wipe clean any oil leaks and firmly tighten the dipstick. Reinstall the oil access cover.

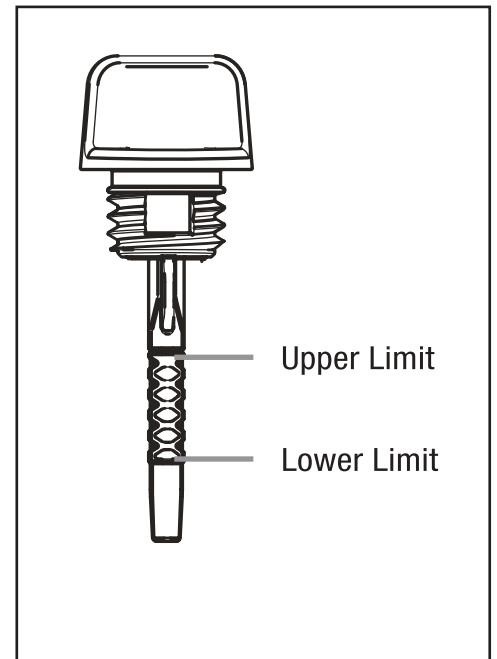

STEP 2 - ADD/CHECK FUEL

- Do not operate near open flame, heat, or any other ignition source.
- Do not smoke near the generator.
- Always operate on a firm, level surface.
- Always turn generator off before refueling. Allow generator to cool for at least 2 minutes before removing the fuel cap. Loosen cap slowly to relieve pressure in tank.
- Do not overfill fuel tank. Fuel may expand during operation. Do not fill to the top of the tank. Allow for expansion.
- Always check for spilled fuel before operating. Clean up any spilled fuel before starting.
- Empty fuel tank before storing or transporting the generator to prevent spilling.

Only fresh diesel fuel can be used, and diesel or diesel mixtures cannot be used.

The capacity of the fuel tank is **18L** DO NOT mix oil with diesel.

NOTICE:

- **Never use an oil / diesel mixture**
- Never use old diesel.
- Keep fuel away from sparks, open flames, pilot lights, heat and other sources of ignition.
- Avoid getting dirt or water into the fuel tank.
- Diesel can age in the tank and make starting difficult. Never store generator for more than 2 months with fuel in the tank.

GENERATOR PREPARATION

To add diesel follow these steps:

1. Make sure the generator is shut OFF and on a level surface. Unscrew the fuel cap and set it aside. The fuel cap may be tight and hard to unscrew.
2. Slowly add diesel to the fuel tank. Be careful not to overfill.

NOTE: Do not fill the fuel tank to the very top. If you do, diesel will expand and spill during use, even with the fuel cap in place.

3. Reinstall fuel cap and wipe clean any spilled diesel with a dry cloth.

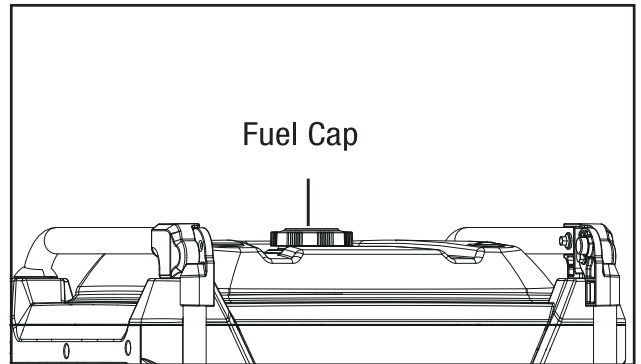

To check fuel level:

During operation, the fuel level will be displayed on the DATA CENTER of the panel, or check the fuel gauge. If the fuel level is low, refill the fuel tank before starting your generator for the next time.

STEP 3 - CONNECT THE BATTERY

⚠ WARNING: BATTERY GIVES OFF EXPLOSIVE HYDROGEN GAS.

- Keep battery away from sparks, cigarettes, or other sources of flame.
- Do not connect or disconnect battery while generator is running.
- Service or use battery only in well ventilated areas.

⚠ WARNING: Battery contains sulfuric acid. Battery acid is poisonous. Tilting the generator with the battery installed can cause battery acid to spill.

- Wear protective clothing and eye wear when servicing battery.
- Keep out of reach of children.
- If battery acid gets on your skin, wash with water immediately.
- If battery acid gets in your eyes, flush with water for at least 15 minutes and call a doctor immediately.

If battery acid is swallowed, call a doctor immediately. Drink a large amount of water or milk. Then drink milk of magnesia or vegetable oil.

The generator is shipped with the battery's negative (-) terminal disconnected to maximize safety. To start the generator using electric start, the battery must be connected.

To connect the battery:

1. Open the upper casing of the generator.
2. Remove the cover from the battery's positive electrode(+) terminal and connect the red cable to the battery's positive electrode(+) terminal.

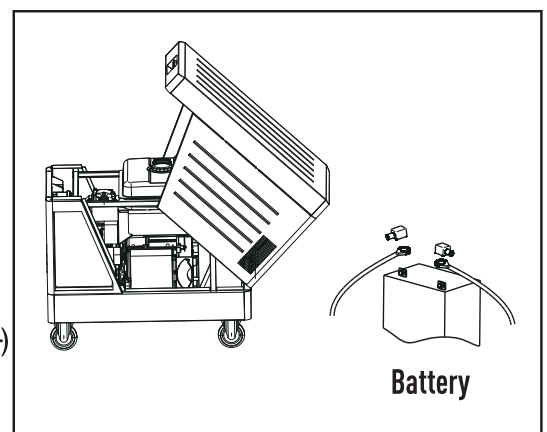

GENERATOR PREPARATION

3. Remove the cover from the battery's negative (-) terminal and connect the black cable to the battery's negative (-) terminal.

The generator's positive pole has already been connected. Double check to confirm that the connection is secure.

NOTICE: If you do not plan to use the generator for a long period of time, we recommend to DISCONNECT the negative battery cable from the battery to protect the battery from losing charge. After disconnecting the cable, cover the free end with an insulator such as electrical tape. You may also choose to use a trickle charger (not included) to maintain battery charge.

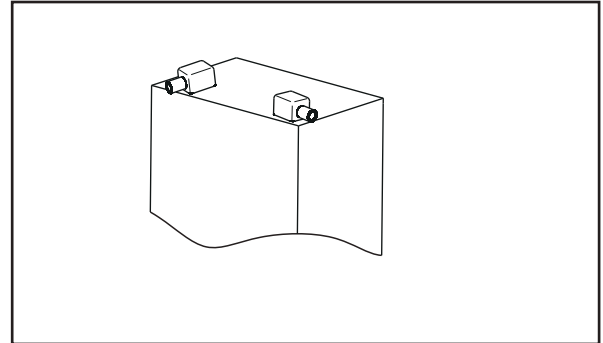

STEP 4 - GROUND THE GENERATOR

To reduce the risk of electric shock and to maximize safety, the generator should be properly grounded.

The leakage protection at the panel end has been completed and the neutral point is grounded.

Ground the generator by tightening the grounding nut on the front control panel against a grounding wire. A generally acceptable grounding wire is a **4mm² (Australian stranded copper wire)**.

This grounding wire should be connected at the other end to a copper, brass, or steel grounding rod that is driven into the earth. Wire and grounding rods are not included with the generator.

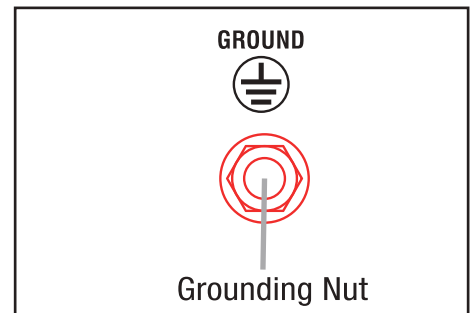
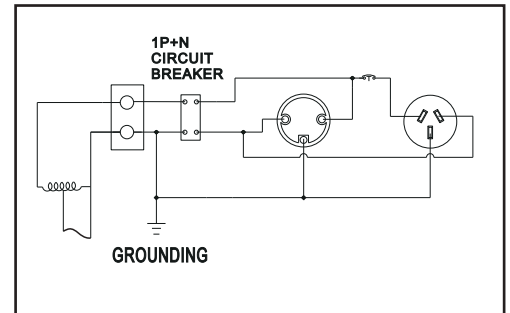

NOTE: Grounding codes can vary by location. Contact a local electrician to check the area codes.



WARNING: Failure to properly ground the generator increases your risk of electric shock.

HIGH ALTITUDE OPERATION ABOVE 915 METERS

The fuel system on this generator may be affected by operation at high altitudes. At elevations above 2438 meters, the engine may experience a decrease in performance, even with the proper altitude kit. Operating this generator may increase the engine's emissions and decrease both fuel economy and performance. Please contact your authorized service center for important information regarding these modifications.

GROUNDING THE GENERATOR

GROUNDING THE GENERATOR

WARNING

In order to avoid electrical accidents, all connections to the distribution panel must be carried out by qualified technicians. Incorrect connections can harm people and damage the generator.

Operating the generator when it's not properly grounded can result in electrical shock.

Standard generators are protected by electrical separators. This equipment has a thermic protection device and/or magnet-to-thermic device to protect against a surge of current, overloading and short-circuiting. In these cases, the generator should under NO circumstance, be earthed using the terminal "PE" or with any other part of the generator.

If a licenced electrician installs the generator with a connection to your building's electrical circuit for use as a back-up power system, grounding may alternatively be completed through the building's grounding system. Ask your electrician.

WARNING

Grounding is not required when the generator is used as a portable power source. Below grounding method is only needed by a qualified electrician if not connecting through your building's electrical system.

If the generator is not grounded through your building's system, follow the procedure below. This procedure can only be carried out by a licensed electrician.

1. Drive a 3/4" or 1" copper pipe or rod into the ground close to the generator. The pipe/rod must penetrate moist earth – the depth required will be dictated by local soil conditions.
2. Connect an approved ground clamp to the pipe.
3. Run a 10-gauge wire from the clamp to the generator grounding post located on the rear of the generator head.
4. Do not connect the generator grounding post to a water pipe or a ground used by the radio system.

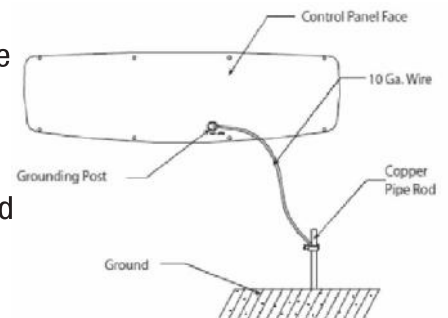

IMPORTANT:

This generator is fitted with a MEN link (yellow-green cable) cable, the neutral is internally bonded to the generator earth. When a licensed electrician is installing the generator to a building to be used as a backup power source, the MEN must be removed. The MEN link is located inside the panel.

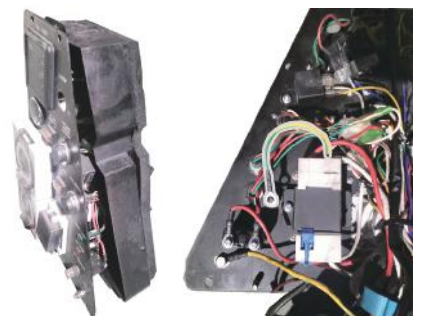

STARTING THE GENERATOR

Before starting the generator, make sure you have read and performed the steps in the “Generator Preparation” section of this manual. If you are unsure about how to perform any of the steps in this manual Please contact your authorized service center

DANGER: CARBON MONOXIDE

Using a generator indoors **CAN KILL YOU IN MINUTES**. Generator exhaust fumes contains carbon monoxide(CO). This is a poison gas you cannot see or smell. If you can smell the generator exhaust fumes, you are breathing CO. But even if you cannot smell the exhaust fumes, you could be breathing CO.

NEVER use a generator inside homes, garages, crawl spaces, or other partially enclosed areas. Deadly levels of carbon monoxide can build up in these areas. Using a fan or opening windows and doors does NOT supply enough fresh air. ONLY use a generator OUTSIDE and far away from windows, doors, and vents. These openings can pull in generator exhaust.

Even if you use a generator correctly, CO may leak into the home. ALWAYS use a battery-powered or battery-backup CO alarm in the home. If you start to feel sick, dizzy, or weak after the generator has been running, move to fresh air RIGHT AWAY. See a doctor. You may have carbon monoxide poisoning.

WARNING: This generator produces powerful voltage, which can result in electrocution.

WARNING: Do not use in rainy or wet conditions. Do not touch bare wires or receptacles (outlets). Do not allow children or non-qualified persons to operate.

WARNING: Generator should ONLY be connected to electrical devices, either directly or with an extension cord. NEVER CONNECT TO A BUILDING ELECTRICAL SYSTEM without a qualified electrician and connected to a transfer switch as a separately derived system. Such connections must comply with local electrical laws and codes. Failure to comply can create a back-feed, which may result in serious injury or death to utility workers.

To maximize safety, ALWAYS ground the generator before using it .

CAUTION: Disconnect all electrical loads from the generator before attempting to start.

STARTING YOUR GENERATOR

Before starting the generator:

1. Verify that the generator is outside on a dry, level surface. Allow at least 1M of clearance on all sides of the generator.
2. To maximize safety, check that the generator is properly grounded (see “GROUND THE GENERATOR”).
3. Check there is sufficient level of oil in the crankcase. Add oil if necessary (see “ADD/CHECK OIL”).
4. Make sure there is sufficient level of petrol in the fuel tank. Add fuel if necessary (see “ADD/CHECK FUEL”).
5. Make sure all electrical devices are unplugged from the generator during ignition. Otherwise it will be difficult for the engine to start.

To start the generator, perform the following steps:

1. Turn the LOW IDLE MODE switch to “OFF”.
2. Turn the FUEL switch to the “ON” position.

One-Button Start:

Turn the "2 wire control switch" off(Press to the left side),press the one push start button 2-3seconds.

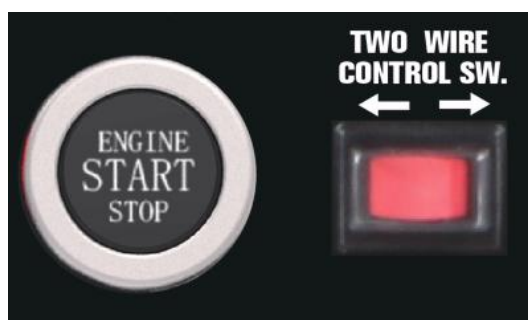

STARTING YOUR GENERATOR

Automatic Electric Starting of the MX8500SD by 2-Wire Auto Start

1. Instruction of two wire start

Start:

- ① Do not press E-STOP unless you need an emergency stop.
- ② Turn the "2 wire control switch" on (Press to the right side)
- ③ Connect the 2-wire aviation socket to the 2-wire control connector and the machine will start. Remove it and the machine will stop.

Stop:

Plug the two wire start connection wire. When the wire is disconnected, generator will stop.

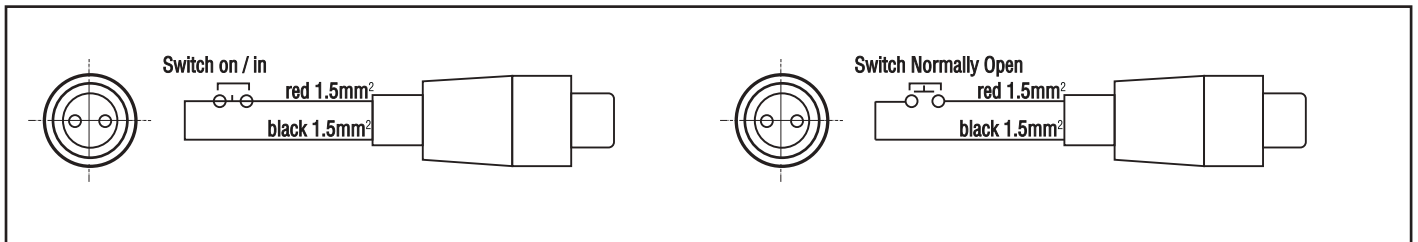
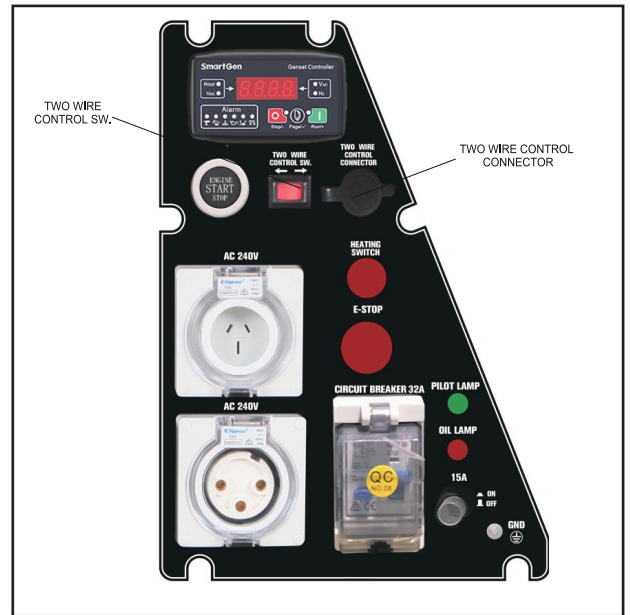

2. When the two-wire control switch is pressed ON, the one push button start, cannot control the starting of the generator set.
3. Only the two-wire control socket (two core aviation) socket can control the start and stopping of the generator set.
4. After 48 hours of turning off the generator set with the one push button start, the generator set will enter the power saving mode. At this time, only the "one push button start" switch will reenergize the generator set to wake up the starter module.
5. Only after the gen set has been woken then the start stop function of the generator set can be controlled again.
6. When the two-wire control switch is pressed OFF, only the one push button starter, can control the starting or stopping of the generator set.

SHUTTING OFF THE GENERATOR

⚠ CAUTION: Unplugging running devices can cause damage to the generator. Never stop the engine with electrical devices connected and running.

1. Turn off all electrical devices prior to unplugging them from the generator. Unplugging running devices can cause damage to the generator.
2. Allow generator to run at no load for a few minutes to stabilize internal temperatures.
3. In the one-button start mode, press the one-button start switch for 2-3 seconds, and the generator set will stop running.

In the two-wire starting mode, disconnect the two-wire connection line and the generator set stops running.

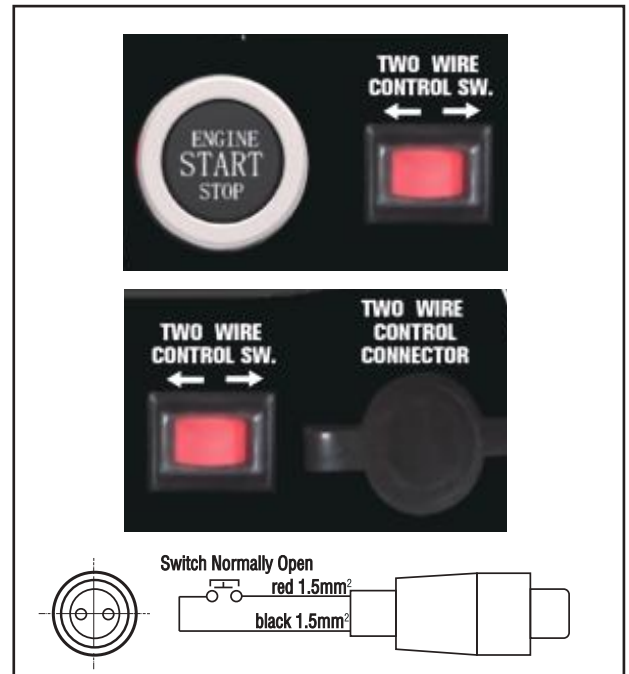

CAUTION: Allowing diesel to sit in the fuel tank for long periods of time can make it difficult to start the generator in the future. NEVER store the generator for extended periods of time (over 2 months) with fuel in the fuel tank. Refer to "STORING THE GENERATOR".

RECOMMENDED MAINTENANCE SCHEDULE

Proper routine maintenance of the generator will help prolong the life of the machine. Please perform maintenance checks and operations according to the Maintenance Schedule. If there are any questions about the maintenance procedures listed in this manual, Please contact your authorized service center.

⚠ WARNING: Never perform maintenance operations while the generator is running. Before maintaining or servicing the generator, turn OFF the generator, disconnect all devices and allow the generator to cool down.

MAINTENANCE

REGULAR MAINTENANCE

Generator Set Maintenance Items And Schedule:

Maintenance time Project	Every day	Every month or 20 hours	Every three months or 100 hours	Every six months or 500 hours	Every year or 1000 hours
Check and add enough fuel	○				
Run out of fuel		○			
Check and add enough oil	○				
Check for oil leakage	○				
Check fasteners	○	● (Tighten the oil pipe bolts)		● (Tighten the cylinder head bolts)	
Change the oil		○ (First time) Replace every 50 hours for the next three times	○ (The fifth time)		
Replace the air filter		(If used in dusty areas, shorten the inspection and maintenance cycle)	○ (Replace)		
Clean the oil filter				○ (Replace, if necessary)	
Clean the fuel filter				○	● (Replace)
Check the high pressure oil pump				●	
Check the injector				●	
Check the fuel pipe				● (Replace, if necessary)	
Adjust valve clearance		● (The first time)			
Grinding valve					●
Replace the piston ring					●
Check battery electrolyte	(Per month)				

Note: The "●" mark indicates a wrench that requires special tools, please contact the dealer.

* Clean/change more often under dusty conditions or operating under heavy load.

IMPORTANT GENERATOR MAINTENANCE TIPS:

- Drain your carburetor after each use and before storage to prevent it from clogging.
- Do not store the generator with fuel inside the tank for more than 2 months - the fuel will go bad.
- Run the generator for at least 20 minutes every month to charge the battery and maximize the generator's lifespan.

NOTE: Failure to properly maintain the generator will void the warranty.

MAINTENANCE

1、 Change the oil regularly

Change the oil after the first 20 hours or the first month, then every 50 hours, and after three times, every 100 hours or three months.

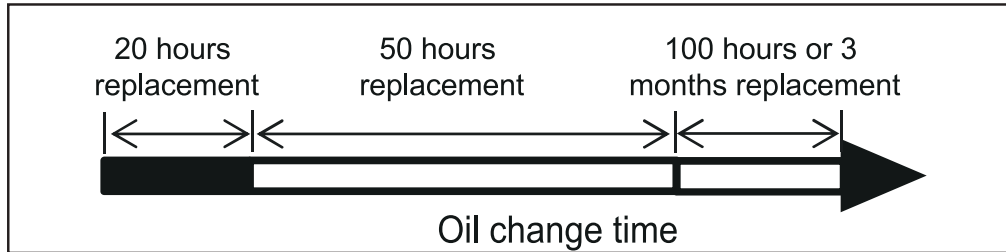

Unscrew the oil dipstick, loosen the oil bolt when the diesel engine is not completely cooled, and drain the old oil. Tighten the oil drain bolt, add new oil, and tighten the oil dipstick.

2、 Cleaning the oil filter

Loosen the locking bolts, take out the oil filter and clean it with petrol or kerosene.

Oil filter	Clean every 5 months or 250 hours, replace if necessary
------------	---------------------------------------------------------

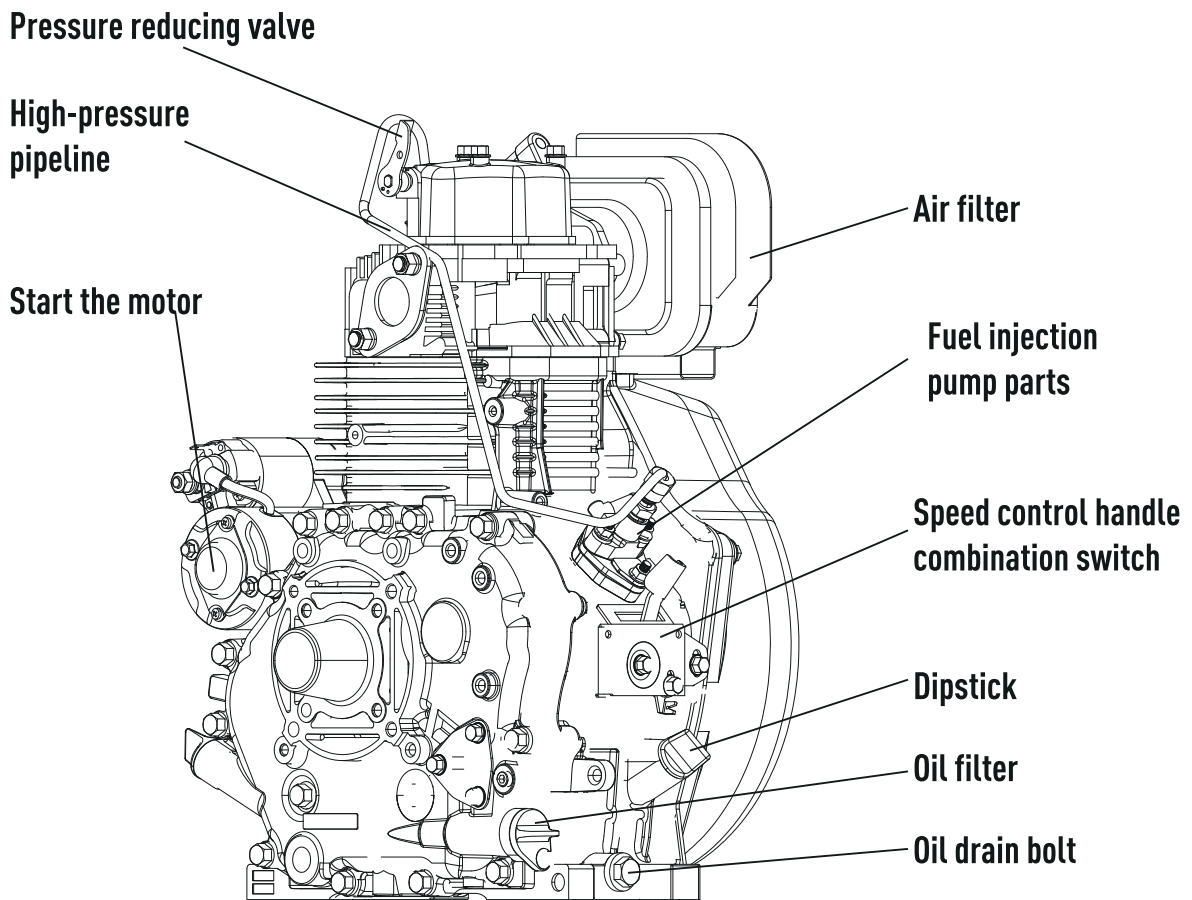

MAINTENANCE

3. Clean and replace the air filter element

Do not use detergent to clean the element of the air cleaner. Use a soft brush or air gun to remove dust on the outer surface of the filter element.

Replacement time	Every 3 months or 100 hours
------------------	-----------------------------

 **Note:** Do not start the diesel engine when there is no filter element or the filter element is damaged.

4. Wash and replace the fuel filter

The fuel filter must be cleaned frequently to ensure that the diesel engine has the maximum output power.

- Drain fuel from the fuel tank.
- Loosen the clamp on the fuel pipe, remove the filter, and clean it thoroughly with diesel.

Cleaning time	Clean every 6 months or 500 hours. If the diesel has more impurities, the cleaning cycle will be shortened
Replacement time	Replace every 1 year or 1000 hours. If the diesel has more impurities, the replacement cycle will be shortened

5. Tighten the cylinder head bolts (see the diesel engine manual for details)

Tightening the cylinder head bolts requires special tools, do not try casually.

6. Check the fuel injector, high-pressure fuel pump, etc.

 **Note:** Do not expose your skin to the fuel spray during operation. Fuel is harmful to the skin; when testing the atomization state of the fuel injector, the exposed skin and eyes must be kept away from the fuel injector.

7. Adjust the clearance of intake and exhaust valves 0.15 ± 0.05 mm.

8. Replace the piston ring.

9. Battery

Before starting the 12V battery used by the unit, check whether the battery is damaged and check the battery voltage. If it is damaged, replace the battery; if the voltage is insufficient, fully charge the battery to start normally.

Normal battery voltage	12V-14V
------------------------	---------

MAINTENANCE

MAINTENANCE FOR LONG-TERM STORAGE

If your generator needs to be stored for a long time, you must do the following:

- 1、 Run the generator set for about 15 minutes and then shut down.

- 2、 After stopping, when the diesel engine is still hot, discharge the old diesel engine oil, and then add new engine oil to the specified height.

- 3、 Unscrew the cylinder head cover bolts, add 2ml lubricating oil, and then tighten the bolts In the same place.

- 4、 Maintenance of the starting part
Turn the start key to the "start" position, and let the diesel engine run for 2-3 seconds (no need to start), then turn the key to the "off" position and pull out the key.

- 5、 Remove the battery from the generator for monthly charging and maintenance.
Keep the battery voltage between 12V-14V during storage. Do not store the battery when the battery voltage is lower than 10.8V to avoid damage. Keep the battery storage place away from sunlight, fire and children to avoid property damage and personal injury.

- 6、 Wipe the generator set clean, store it in a dry and stable place, and lock the wheels.

TRANSPORTATION & STORAGE

TRANSPORTING THE GENERATOR

To prevent fuel spillage when transporting, be sure to perform the following:

1. Tighten the fuel cap and turn the vacuum relief valve to “OFF”.
2. Set the engine switch to “OFF”.
3. Drain the fuel tank if possible.
4. Keep the generator upright. Never place the generator on its side or upside down - doing so will make it difficult to start.

 **WARNING:** Avoid direct sunlight inside a vehicle. If the generator is left in an enclosed vehicle for many hours, the high temperature could cause the fuel to vaporize and result in a possible explosion.

STORING THE GENERATOR

Shut off the generator and allow the unit to cool to room temperature before storing it. NEVER place any type of storage cover on the generator while it is still hot. Do not obstruct any ventilation openings.

Follow the procedures below for properly storing your generator. We highly recommend running your generator once a month for 20 to 30 minutes. Plug in a small load in to ensure there is proper power output.

For Short Periods (30 to 60 Days):

- Disconnect the negative lead from the battery.

For Extended Periods (Over 60 Days):

- Disconnect the negative lead from the battery.
- Empty the fuel tank. Don't store fuel in the tank for two months

- Change the engine oil (see “CHANGING OIL”).

 **WARNING:** Store the generator upright in a cool and dry location, away from sources of heat, open flames, sparks or pilot lights.

PRODUCT DISPOSAL

Do not dispose of used generator or parts with your household waste. This product contains electrical or electronic components that should be recycled. Please take this product to your local recycling facility for responsible disposal to minimize its environmental impact.

Do not dispose of used oil or fuel in the trash or down a drain. Please contact your local recycling center or auto garage to arrange proper oil/fuel disposal.

TROUBLESHOOTING METHODS

COMMON FAULTS AND TROUBLESHOOTING

Frequently Asked Questions

	Cause of issue	Method of exclusion
Diesel engine fails to start or does not operate normally after star	Not enough fuel	Add fuel
	High-pressure oil pump and fuel injector do not inject oil or have little oil injection	Dismantle and repair high-pressure fuel pump and fuel injector, and debug on the fuel injector test bench
	Check oil level	The standard amount of lubricating oil should be between the upper and lower scale lines
	Fuel injector clogged	Cleaning the fuel injector
	Low battery	Charge the battery or replace the battery
	There is air in the high-pressure oil pump	Remove air(see 4.1.5 for details)
	The oil pressure alarm is locked, the key does not respond when starting	Check the lubricant, put the key in the "off" position for 2 seconds and start again
The generator does not generate electricity	Poor socket contact	Adjust socket contacts
	The generator has not reached the rated speed	After reaching the rated speed,switch on the load
	Blown fuse	Check if there is a short circuit due to wire damage in the panel, replace the fuse
	Load leakage	Eliminate the leakage of the load, check whether the grounding is good,and re-close
	Regulator wiring is broken or damaged	Rewire or replace with new regulator
Low voltage	The engine has not reached the rated speed	Fine-tune the speed regulating spring to the rated speed
	Damaged display	The test output voltage of the multimeter is compared with the display meter. If the display meter is broken, replace it.
	Regulator wiring is broken or damaged	Rewire or replace with new regulator
Automatic shutdown after a period of operation	Insufficient lubricating oil, resulting in low oil pressure, low oil pressure alarm	Add proper amount of lubricating oil, put the start key in the"off" position for 10 seconds, start again
	Fuel exhausted	Check the fuel quantity and check whether the oil circuit (diesel filter,fuel injector, oi pump,etc.) is blocked
	Speed control spring falls off	Adjust the speed control spring hook surface,reinstall,-adjust

TROUBLESHOOTING METHODS

After repairing the generator according to the above method, if it still fails to generate electricity, please contact our company's special dealer or directly contact our company.

Doubts and problems

If you don't understand some operating instructions or encounter any problems during the operation, you can contact our company's authorized dealer or directly contact our company and provide the following:

- Diesel generator model and diesel engine number: The diesel generator model is affixed to the box, and the diesel engine model and number are engraved on the body next to the oil drain bolt.
- Status: During the operation of the generator, at what speed, what working environment, and what problems occurred.
- How much time has the generator set accumulated.
- Other details and specific time when the problem occurs.

WARRANTY INFORMATION

WARRANTY CONDITIONS

Thank you for purchasing a quality Maxwatt Power product.

Subject to the exclusions set out below.

Maxwatt Power Products PTY Ltd (the "Company") warrants that that this product will be free from defects in materials or workmanship for (2) years or (500) operating hours, whichever occurs first, from the date of original sale (hereinafter the "Warranty Period") in normal domestic applications such as personal, residential household or recreational use from the date of purchase.

A Warranty Period of (2) years or three hundred (300) operating hours, whichever occurs first, shall apply in commercial applications such as income producing, rental or other business-related use. Goods sold to a Consumer with an Australian Business Number shall be deemed as being used in a commercial application.

The Warranty Period is continuous from the date of original sale and does not restart upon the repair or replacement of the Goods or any part thereof.

The benefits conferred by this warranty are in addition to all rights and remedies which you may be entitled to under the Australian Consumer Law and any other statutory rights you may have under other applicable laws. This warranty does not exclude, restrict, or modify any such rights or remedies.

LIMITED WARRANTY

"This is a "walk in" warranty policy and is limited to the range of generators specified herein". We recommend that you take the generator to the nearest service agent for assistance. Please visit www.maxwatt.com.au for more information. Upon return -transportation charges shall be borne and prepaid by the Consumer -to the Company's or its nominated dealer's premises within the Warranty Period, the Company shall repair or replace, at its option, any Goods which it determines to contain defective material or workmanship and shall return said Goods to the Consumer free-on-board at the Company's or agent's premises. The repair or replacement work will be scheduled and performed according to the Company's normal workflow and availability of replacement parts.

The Company shall not be obligated, however, to repair or replace Goods which have been repaired by others; abused; improperly installed, operated, maintained, repaired, transported, or stored; not serviced to schedule using genuine spare parts; altered or otherwise misused or damaged in any way. This warranty does not apply where a defect or other issue with the product is caused by normal wear and tear, misuse, or abuse of this product.

WHAT THE APPOINTED SERVICE AGENT WILL REPAIR OR REPLACE UNDER WARRANTY:

"The appointed Service Agent will repair or replace, at its sole discretion, any part that is proven to be defective in material or workmanship under normal use during the applicable warranty time period. Warranty repairs will be made without any charge for parts and labour.

All parts replaced will be considered as part of the original product and the warranty on such parts will expire coincident with the original product warranty.

WARRANTY INFORMATION

EXCLUSIONS TO THIS LIMITED WARRANTY INCLUDE:

Neglect in the periodic maintenance as specified in the owner's manual.

Improper repairs or maintenance including any repairs and or maintenance carried out by a non- accredited service agent.

Operating methods other than those indicated in the owner's manual.

The use of non-genuine parts and or accessories other than those supplied by an accredited service agent.

Normal wear and tear including but not limited to the fading of painted or plated surfaces.

Consumable parts including but not limited to keys, spark plugs, fuel and oil filters, recoil starter ropes, wheels, lubricants, oil, grease, and fuel.

Cleaning adjustments and normal periodic maintenance work including but not limited to cleaning the battery, carburetor, engine oil, fuel tank and injectors.

Overloading resulting in the damage of the circuit breaker, stator and rotor. Charging and proper maintenance of the battery.

Correct preparation when using the generator for the first time as set out in the owner's manual.

Fire damage because of but not limited to overloading, incorrect installation, incorrect re-fueling and any other causes as set out in the owner's manual.

Damage to any electronic and or electrical appliances connected to the generator.

BELOW IS A TABLE OF PARTS THAT ARE LIMITED BY THIS WARRANTY

BELOW TABLE OF PARTS THAT ARE LIMITED BY THIS WARRANTY:

PARTS	OUT OF BOX FAILURE(LESS THAN 20 RUNNING HOUR)
STATOR	X
ROTOR	X
CIRCUIT BREAKER	X
FUEL INJECTION PUMP	X
VOLTAGE STABILIZER	X
BATTERY	X

*NOTE:

OUT OF BOX FAILURE REFERS TO A MACHINE THAT HAS RUN FOR <20 MINUTES.

WARRANTY INFORMATION

DISCLAIMER OF IMPLIED WARRANTIES

Maxwatt Power Products disclaims any responsibility for the loss of time or use of the product, transportation, commercial loss or any other incidental or consequential loss or damage. Any implied warranties are limited to the duration of this written limited warranty policy and procedures manual.

Proof of Purchase

It is recommended that you keep a copy of the original tax invoice for your records.

Warrantor

Name: Maxwatt Power Products Pty Ltd





Address: Unit 15/16 1440 New Cleveland Road Chandler 4155

Phone:0737325363

Email: customercare@maxwatt.com.au



















Web: www.maxwatt.com.au

Please Note the Following Terms & Conditions.





-  — Customer is required to return the generator to the store.
-  — The generator will be repaired at no charge to the customer should the fault be deemed a manufacturer defect only.
-  — The approximate lead time for repairs is **14 -21 working days** from the time the generator is received at the Maxwatt Service Center.
-  — A copy of the proof of purchase is required when returning the generator for repairs. The warranty is null and void without a copy of proof of purchase.

WARRANTY INFORMATION

✗ *NOTE: THE FOLLOWING IS EXCLUDED FROM THE MANUFACTURER WARRANTY POLICY.

- ✗  — Neglect in the periodic maintenance as specified in the owners / operator's manual.
 - ✗  — Operating methods other than those indicated in the owner / operator's manual.
 - ✗  — Overloading resulting in the damage to the Inverter / Circuit Breaker / Alternator.
 - ✗  — Improper repairs or maintenance carried out.
 - ✗  — Normal “wear & tear” due to day- to-day use & operation.
 - ✗  — The in-correct installation resulting in the damage to the Inverter / Alternator / Control Panel and remote.
-
- ✗  —  Spark Plug
 -  Oil
 -  Fuel & Oil Filters
 -  Recoil Starter Rope
 -  Wheels
 -  Fuel
 -  Flat Battery
-
- ✗  —  AVR
 -  Alternator
 -  Circuit Breaker
 -  Control Panel

✓ CHECK LIST PRIOR TO SENDING THE GENERATOR IN FOR ASSESSMENT / REPAIR.

- ✓  — Ensure that the battery is charged.
- ✓  — Ensure that there is the correct amount of oil and that it does not need to be replaced.
- ✓  — Ensure that there is sufficient fuel.
- ✓  — Ensure that the spark plug does not need to be cleaned or replaced.
- ✓  — Ensure that the generator has been serviced if it has run for more than 50 hours. Check the owners / operator's manual for information.



Distributed by: Maxwatt Power Products
Unit 15/16, 1440 New Cleveland Road, Chandler
Queensland
Australia