

# MAXWATT

POWER WHEN YOU NEED IT

---

## Generator Operator' sManual



## **⚠ WARNING**

This product can expose you to chemicals including arsenic and lead which has been associated with birth defects and can be hazardous to our health.

## **⚠ DANGER**

Using a generator indoors **WILL KILL YOU IN MINUTES**. Exhaust contains carbon monoxide, a poison gas you cannot see or smell.



**NEVER** use in the home or in partly enclosed areas such as garages.



Only use **OUTSIDE** and far from open windows, doors, and vents.

Avoid other generator hazards.  
**READ MANUAL BEFORE USE.**

# TABLE OF CONTENTS

---

SPECIFICATIONS for Model MX2500iS	1
ABOUT YOUR GENERATOR	2-5
GENERAL SAFETY RULES	6-11
GENERATOR SET UP AND OPERATION GUIDELINES	12-21
CONTROLS FUNCTIONS, AND FEATURES AND DIAGRAMS	22-27
PRE-OPERATING CHECKS	28-31
STARTING THE ENGINE	32-36
STOPPING THE ENGINE	37-38
TROUBLESHOOTING AND SPECIFICATIONS	39-44
MAINTENANCE	45-50
MAINTENANCE LOG	51-56
WIRING DIAGRAM	57
LABELS	58
WARRANTY INFORMATION	59-64

## **SPECIFICATIONS:**

Model NO: MX2500iS

Running Watts: 2200W

Rated Voltage: 240V

Engine RPM: 3600-5300

Engine: 98cc OHV

Rated Frequency: 50Hz

Rated Current: 9.2A

Starting Watts: 2500W

Phase: Single

IP Class: 23

Fuel Capacity:4.2L

Starting:Manual Recoil Start

Fuel:Petrol

## **ABOUT YOUR GENERATOR**

Thank you for purchasing a MAXWATT generator (hereinafter referred to as the generator).

This generator is suitable for use on various trade worksites, recreational such as camping and for use as backup power whether residential or commercial.

Please read and understand this manual for instructions on start-up, shut down, operations, adjustments, maintenance as well as safety guidelines before using this product. Please take all possible precautions to protect your own safety and that of the people in the immediate vicinity. This manual is the latest version. Save this manual for future reference.





As this product is continuously improved and upgraded, the manufacturer reserves the right to modify this manual without notice.

The manufacturer shall not assume any liability for incorrect information contained in this manual.

This manual is an essential and important tool for the use of the generator. When the generator is transferred to new owners, the manual must be given to the new owners as well.

Some important information in this manual will be indicated in the following way. The owner/ user must pay special attention to these instructions.

## HAZARD SIGNAL WORD DEFINITIONS

	Indicates an imminently hazardous situation which, if not avoided, will result in death or serious injury. Obey all safety messages that follow this symbol to avoid possible injury or death.
 <b>DANGER</b>	Indicates an imminently hazardous situation which, if not avoided, will result in death or serious injury.
 <b>WARNING</b>	Indicates a potentially hazardous situation which, if not avoided, could result in death or serious injury.
 <b>CAUTION</b>	Indicates a potentially hazardous situation which, if not avoided, may result in minor or moderate injury.
<b>CAUTION</b>	Used without the safety alert symbol indicates a potentially hazardous situation which, if not avoided, may result in property damage.

For any queries on the above, please contact Maxwatt power products, the official service agent for all MAXWATT generators and water pumps.

The range of MAXWATT generators is safe and reliable, but incorrect usage of these products may cause personal injury and damage to the machine.

In order to operate the generator safely, strictly adhere to the operator's manual and please read it through carefully and thoroughly before using the generator.

### BEFORE STARTING

#### UNPACKING AND DELIVERY INSPECTION

You should inspect the generator immediately after you receive delivery thereof. If you have any missing parts, please contact your place of purchase. DO NOT attempt to operate the generator if there are any missing parts.

The generator is shipped without oil. You must add an adequate amount of engine oil before using it for the first time. The engine will be damaged beyond repair if it is started without oil. For oil type, please see "Recommended Oil Type" section of this manual on page 9. Fresh regular RON 91 fuel must be used in this unit. DO NOT use Premium or Ethanol based fuels.

## **SAFETY SIGNS**

Comply with the instructions provided by the safety signs and symbols fitted to the generator and in this manual. The generator and manual only feature

the symbols relevant to the model purchased. Check that the symbols and signs affixed to the unit are always present and legible, otherwise fit replacements in the original positions.

## **GENERAL WARNINGS & DISCLAIMER**

READ and UNDERSTAND this manual completely before using the engine. Failure to properly set up, operate and maintain this engine could result in serious injury or death from carbon monoxide poisoning, electric shock, fire/explosions or burns. In particular be aware of the following hazards:

### **CO POISONING**

Engines give off carbon monoxide fumes, an odorless, colourless poisonous gas that can kill you. You CANNOT smell it, see it or taste it. ONLY run an engine OUTDOORS and AWAY from building air intakes.

NEVER run an engine inside any enclosed or semi-enclosed spaces, including homes, basements, garages, sheds, boxes, RV's, boats or pick-up truck beds. These spaces can trap poisonous gases, EVEN if you run a fan or open windows.

### **ELECTRIC SHOCK / ELECTROCUTION**

High voltage electricity from the generator can kill. DO NOT operate in wet locations or conditions. Be sure the generator is properly grounded. Use only outdoor rated grounded extension cords of proper size.

NEVER plug the generator directly into a wall plug outlet. ANY connection to a building's electrical system MUST ISOLATE THE GENERATOR FROM UTILITY POWER via a transfer switch installed by a licensed electrician.

Otherwise, the back-feed from the generator into the power grid could kill utility workers. See "Set up as a building back-up" on page 13 for additional information.

BEFORE performing any maintenance on the generator, disconnect the engine starting battery (if equipped) to prevent accidental start-up. Disconnect the cable from the battery post indicated by a NEGATIVE, NEG or (-) first. Reconnect the cable last.

## **HEAT**

Unintentional spark can result in fire or electric shock.

## **FIRE/EXPLOSION**

DO NOT overload the engine (per rate capacity) and OPERATE ONLY in an area with adequate cooling ventilation so the engine does not overheat. The exhaust can be extremely hot. Keep the muffler at least 3 meters from all combustible objects.

All fuels are flammable. Never fuel a running or hot engine. Never pump fuel directly into the engine at a petrol station – use an approved container to transfer the fuel. Ensure that there are no fuel leaks and keep sources of sparks and flames away. Wait for the engine to be cool before fueling. ALWAYS keep a fire extinguisher rated “ABC” nearby.

## **STOP!**

CHOOSE THE RIGHT GENERATOR FOR YOUR NEEDS.

See the Power Load Planning and Management section to determine your power load requirements and then compare to the generator’s rate capacity.

## **INSPECT COMPONENTS**

Closely inspect to make sure that there are not any components missing or damaged.

**ARRANGE FOR PROFESSIONAL INSTALLATION** of a transfer switch if you will be connecting the generator to your building’s system.



## GENERAL SAFETY RULES FOR OPERATION



### WARNING

Read all safety warnings, instructions, illustrations and specifications provided with this generator. Failure to follow all instructions listed below may result in electric shock, fire and/or serious injury.

### Save all warnings and instructions for future reference.

This equipment is to be used for the purpose for which it is designed and intended.

Seek assistance if required when moving or lifting the generator.

### WORK AREA SAFETY

- Intended for outdoor use only. DO NOT operate in confined spaces or indoors as carbon monoxide released from the exhaust can kill.
- DO NOT operate in explosive atmospheres such as in the presence of flammable liquids, gases or dust.
- Keep children and bystanders away while operating a generator. Distractions can cause you to lose control.
- Keep your work area clean and well lit. Cluttered benches and dark areas invite accidents.
- This generator is not weatherproof. Exposure to rain, damp conditions or extreme temperatures can cause damage or serious injury.

### PERSONAL SAFETY

- Stay alert, watch what you are doing and use common sense when operating a generator.
- DO NOT use a generator while you are tired or under the influence of drugs, alcohol or medication. A moment of inattention may result in serious personal injury. Use personal protection equipment. Always wear eye protection. Wear approved safety impact eye goggles, dust mask, non-skid safety shoes, hard hat and hearing protection for appropriate conditions.
- DO NOT overreach. Keep proper footing and balance at all times. This enables better control of the generator in unexpected situations.

- Dress properly. DO NOT wear loose clothing, gloves, neckties or jewelry. Keep your hair and clothing away from moving parts. Loose clothes, jewelry or long hair can be caught in moving parts.
- DO NOT let familiarity gained from frequent use of the generator allow you to become complacent and ignore safety principles and rules. A careless action can cause severe injury within a fraction of a second.
- For your own safety, do not operate your generator until it is completely assembled and installed according to the instructions and until you have read and understood all of the instructions.

### **GENERATOR SAFETY RULES**

- DO NOT force the generator. Use the correct generator for your application. The correct generator will do the job better and safer at the rate for which it was designed.
- DO NOT use the generator if the engine switch does not turn it on and off. Any generator that cannot be controlled with the switch is dangerous and must be repaired.
- Know how to stop the generator without hesitation. Be thoroughly familiar with proper use of the equipment and all engine controls, output receptacles and connections. Know how to stop the engine quickly (see “Stopping the Generator”).
- The engine owner must instruct all operators in safe engine set-up and operation. Only trained adults should set up and operate the engine. DO NOT let children operate it.
- Carefully read about and understand the intended use of this engine. DO NOT use for other purposes as unforeseen hazards or equipment damage may result.
- NEVER operate or let anyone else operate the engine while under the influence of alcohol, drugs or medication.
- DO NOT operate the engine unless all safety covers, guards and barriers are in place and in good working order – and that all controls are properly adjusted for safe operation.
- DO NOT operate the generator with damaged, missing or broken parts.
- DO NOT modify the generator in any way. Modifications can create hazards and will also void the warranty.

- NEVER attempt to modify the generator speed setting. The generator speed is present for safe and optimal performance of the generator. If speed needs adjusting, it must be done by factory personnel.
- NEVER attempt to connect external fuel sources in order to increase generator run time. A larger tank at pressure or higher elevation will cause a leak from the carburetor during operation. A fire or an explosion could result.
- Always turn off the generator and remove the spark plug(s) or spark plug wire(s) before working on the generator to prevent accidental starting.
- Always discharge the capacitor before working on the generator head to prevent electrical shock. (See Maintenance & Repair section of this manual for instructions on how to do this.)
- The running generator gives off carbon monoxide, a poisonous gas that can kill you. You CANNOT smell it, see it, or taste it. Follow all instructions for site selection and positioning of the generator and avoid inhaling the exhaust. If you start to feel sick, dizzy or weak while using the generator, shut off the generator and get to fresh air RIGHT AWAY. See a doctor. You may have carbon monoxide poisoning.

Immediately turn off the generator if any of the following conditions arise during operation:

1. Excessive change in generator speed, slow or fast;
  2. Sparking or arcs from generator;
  3. Loss of electrical output;
  4. Receptacle damage;
  5. Generator misfire;
  6. Excessive vibration;
  7. Flame or smoke or Abnormal noise.
- This product contains or emits chemical known to the Commonwealth of Australia to cause cancer, birth defects or other reproductive harm. Avoid inhalation of exhaust fumes.
  - DO NOT operate the engine or handle any electrical equipment

while standing in water, while barefoot, while hands are wet or while in the rain or snow. An electric shock may result.

- Avoid contact with bare wires, terminals, connections, etc. while the generator is running.
- If an electric shock accident occurs, immediately shut down the source of electrical power. If this is not possible, attempt to free the victim from the live conductor. Avoid direct contact with the victim. Use a non-conducting implement, such as a dry rope or board, to free the victim from the live conductor. Administer/apply applicable first aid and get immediate medical help.
- Never smoke near the running engine and never operate near sources of sparks or flames.

## **SERVICE**

Have your generator serviced by a qualified repair person using only factory approved replacement parts. This will ensure that the safety of the generator is maintained. Incorrectly fitted parts will void your warranty.

The equipment may only be used, maintained or repaired by those persons who understand and have been instructed about the potential dangers.

Independent changes in the equipment cancel any manufacturer's liability for any damages that result from these changes.

## **APPROPRIATE USE**

Use the equipment only when it is in technically perfect condition and only for appropriate jobs, with an awareness of safety and possible dangers, based on observation of the operating instructions. In particular, problems which could influence the operational safety must be dealt with immediately.

All of the manufacturer's safety, work and maintenance regulations as well as the given norms in the Technical Data must be observed.

## **STATIC ELECTRICITY AND FILLING THE PETROL TANK**

Static electricity can initiate from un-grounded petrol tanks or containers from flowing petrol and persons carrying a static electric charge. Static electricity can explosively ignite petrol vapours that are present during the fueling process, resulting in serious burns to nearby persons.

Many objects can accumulate and retain a static electric charge. Objects made of non-conductive materials (eg. plastics) easily accumulate and retain static electrical charge, as can objects made of conductive material (eg. metal, water) if they are not electrically grounded.

To avoid static electricity while fueling, certain steps must be followed before and during the fueling process in order to minimize and safely dissipate static charge build-up:

- Touch a grounded metal object before starting.
- Always dissipate static charge from your body before beginning the fueling process by touching a grounded metal object at a safe distance away from the fuel source.
- Use a portable container to fill the tank. NEVER fill the engine's petrol tank directly from the fuel pump – the engine's tank is not grounded and the high velocity flow of petrol from a fuel pump can cause static electric build-up. Use an approved portable container to transfer to the engine's tank.

## **TYPICAL SOURCES OF STATIC ELECTRIC HAZARDS DURING FUELING**

The following objects can accumulate a static electric charge and cause an ignition spark in typical fueling situations:

**Ungrounded tanks/containers.**

Any ungrounded fuel tank or container can accumulate a static electric charge as a result of contact with other objects or friction during transportation. This static electricity can discharge as a spark to the grounded petrol dispenser nozzle as the nozzle is first brought close to the tank/container at the beginning of the fueling process.

Flowing petrol. Most people are not aware that petrol accumulates static electric charge while flowing through a hose or pipe. This charge then transfers to and accumulates in the gas tank or container that is being filled. The total amount of charge accumulation depends on the amount of gas pumped into the container, the speed with which it is pumped, and whether or not the tank/ container is grounded. If sufficient static electric charge accumulates in the fuel tank or container during the fueling process, the tank/container may discharge a spark to the grounded petrol dispenser nozzle.

A person dispensing the petrol can carry a static electric charge on their body, typically resulting from contact with their car seat or electronics. The static electricity can discharge a spark between that person's hand and either the grounded dispenser nozzle or the fuel tank opening.

## GENERATOR SET UP

### PLANNING THE POWER LOAD

Plan your power load so that you do not exceed the generator's rated capacity. To calculate the running and start wattage requirements for the devices you will be powering, follow the steps on page 18.

### SET UP THE PORTABLE POWER SOURCE

This generator is designed to provide up to its maximum power (in watts) of electrical power. When using the generator as a portable power source, you can plug electric devices and appliances directly into the generator's electrical outlets. This generator is equipped with two SAA approved IP44 rated socket outlets. Make sure you plug each electrical device/appliance into the correct generator outlet based on the device's plug configuration and voltage/ampere rating. NEVER exceed the ampere rating of an outlet.

**Note:** You must NOT overload the generator.

Overloading may cause serious damage to the generator and attached electrical devices.

### SET UP AS BUILDING BACK UP

To set up as a building backup, you must arrange for a licensed electrician to connect the generator to your building's electrical system via the installation of an approved transfer switch. The transfer switch must be installed in accordance with the building's electrical code and guidelines supplied by the power company.

A transfer switch does the following:

Safely connects the generator to your building's electrical system by isolating your generator from your utility company's power lines.

Connects your generator to a critical subset of your building's circuits that are needed for emergency power needs.



A transfer switch must be installed in order to isolate your generator from the utility power grid. If your generator is NOT properly isolated from the utility system, serious hazards will arise.

When your generator is running, its output will back feed into the utility power line and transformer that are normally used to provide you with power. The transformer will step up the current to the normal line voltage. An unsuspecting utility line worker working on what he thinks is a deactivated line could be electrocuted.

If your generator is connected (running or not) when utility power is restored, your generator will be destroyed. It could also explode or cause fire.

**Note:**

Regardless of whether you use your generator as a back-up power source connected to a building or as a portable power source, you **MUST NOT** overload the generator. Overloading may cause serious damage to the generator and attached electrical devices.

If your generator will be connected to your building's system, it **MUST ALWAYS BE** isolated from the utility power grid with an approved transfer switch installed by a licensed electrician, in compliance with all applicable building and electrical codes and in accordance with the guidelines supplied by the power company.

There may be Federal or State Occupational Safety and Health Administration (OSHA) regulations, local codes or ordinances that apply to the intended use of the generator.

Please consult a qualified electrician, electrical inspection or the local agency having jurisdiction.

In some areas, generators are required to be registered with local utility companies. If the generator is used at a construction site, there may be additional requirements that must be observed.

**GROUNDING THE GENERATOR**

Standard generators are protected by electrical separators.

This equipment has a thermic protection device and/or magnet-to-thermic device to protect against a surge of current, overloading and short-circuiting.

In these cases, the generator should under **NO** circumstance, be earthed using the terminal "PE" or with any other part of the generator.

If a licensed electrician installs the generator with a connection to your building's electrical circuit for use as a back-up power system, grounding may alternatively be completed through the building's grounding system.

Ask your electrician.

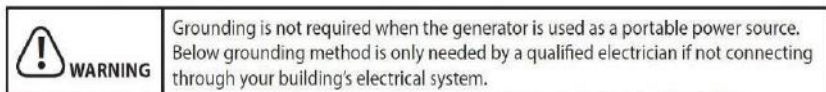



If the generator is not grounded through your building's system, follow the procedure below. This procedure can only be carried out by a licensed electrician.

1. Drive a ¾" or 1" copper pipe or rod into the Ground close to the generator. The pipe/rod must penetrate moist earth – the depth required will be dictated by local soil conditions.
2. Connect an approved ground clamp to the pipe.
3. Run a 10-gauge wire from the clamp to the generator grounding post located on the rear of the generator head.
4. Do not connect the generator grounding post to a water pipe or a ground used by the radio system.

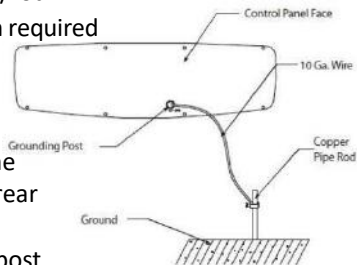

## EXTENSION CORDS

Extension cords may be used to power devices that are located at a distance from the generator. However, use only Australian approved outdoor-rated, grounded extension cords.

Locate the generator in a convenient place and where possible, avoid long extension leads and possible damage to leads by pedestrian or vehicular traffic.

Extension leads should be heavy duty with at least 1mm of appropriate current rating and in any case, not less than 1mm cross-section of conductor and must incorporate an earthing conductor to ensure that there is not any voltage difference between the generator set and any equipment powered by the generator.

The electrical continuity of the “earthing” core should be checked periodically from pin to socket to ensure continued electrical safety.



Use of under sized extension cords can cause electric shock, fire, or damage to connected devices. All extensions and appliance cords must be in good working condition and not worn, bare, frayed, or otherwise damaged.

Use of damaged electric cords can cause electric shock or fire. Note: If an extension cord becomes hot to the touch, it is overloaded or damaged and must be replaced. Maxwatt is NOT responsible for damage or injury resulting from customer use of inadequate extension cords.

## SELECT A SUITABLE SITE

Before using the generator, you must select a suitable **OUTDOOR** location for installation and operation that meets the following criteria:

### DRY, LEVEL SURFACE

The generator should be positioned on a dry, firm and level surface. Ensure that the generator sits level and will not slide or shift during operation. If applicable, block the generator’s wheels to prevent sliding and shifting.



You must choose a suitable site for operating your generator to avoid equipment damage and/or injury and possible death from carbon monoxide poisoning, electric shock, or fire.

## OUTDOORS ONLY



The exhaust from your generator contains carbon monoxide (CO), a poisonous gas that can kill. You cannot smell it, see it or taste it. Breathing carbon monoxide can cause a loss of consciousness and may lead to death. Never run your generator in a closed or semi-enclosed area or near open windows outdoors.

Never attempt to attach ductwork to the muffler system to allow for installation in an enclosure. This could cause hot air and heat build up and increased exhaust back pressure, resulting in exhaust leakage or damage to the generator.

Follow the directions below for choosing a location to operate your generator in order to avoid carbon monoxide poisoning:

- The location you choose to operate the generator must be **OUTDOORS** and away from all building air intakes.

- Never run the generator inside any closed or semi-enclosed spaces (even if outdoors), including homes, garages, basements, sheds or boxes. These spaces can trap poisonous gases, even if you run a fan or open windows.
- Ensure that working, battery-operated or battery back-up carbon monoxide alarms are used in any dwelling/structure that is in close proximity to the running operator.

**Note:** This generator is NOT designed or approved for use in vehicles or marine applications. Never run the generator inside RVs or other vehicles such as boats or on pick-up truck beds.

### ADEQUATE COOLING AND VENTILATION

- The generator needs adequate unobstructed flow of air to allow for proper cooling of the engine and generator.
- Never place the generator immediately adjacent to a building or other structure – allow at least 2 meters clearance.
- Do not run the generator in close proximity to other heat-generating equipment, such as another generator.
- The combined heat that is generated may raise air temperature in the immediate area and there will not be adequate cooling ventilation.
- Do not allow debris to accumulate and block airflow. Do not operate with a tarp, blanket, or cover surrounding the generator.

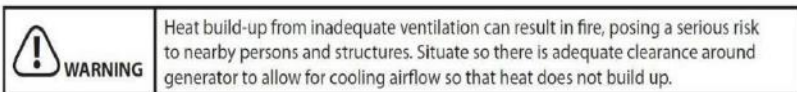

### HOT EXHAUST CLEARANCE

- Make sure your generator's exhaust system is at least 2 meters from all combustible materials and buildings/ structures.
- Equip the engine with a spark arrestor if the generator will be used near any ignitable forest, brush, or grassy land. (see the "Specifications" section of this manual to determine if your generator is already equipped).
- Make sure you comply with applicable local, state and federal codes.

- Keep a fire extinguisher rated “ABC” nearby. Keep it properly charged and be familiar with its use.

### **NO WET CONDITIONS**

Choose a location where the generator will NOT be exposed to rain, snow or direct sunlight. Exposure to water can cause an electric shock. You may operate the generator under an outdoor canopy-like structure of heat-resistant material that is open on all sides.

Make sure that all parts of the canopy are at least 2m from the exhaust and allow for adequate clearance above the generator so that heat does not build up.

### **OPERATE AWAY FROM DUST/DIRT**

Do not use the generator in extremely dusty or dirty conditions. Excessive dust and dirt can cause premature failure of the machine.

### **HEARING PROTECTION**

Generators can produce noise levels >70dB in close proximity, which can be dangerous to human hearing with prolonged exposure to the running generator for an extended period of time.

 <b>WARNING</b>	Never attempt to attach ductwork to the muffler system to lower noise levels. This could cause hot air deflection, heat build-up and increased exhaust back-pressure, resulting in possible exhaust leakage or damage to the generator.
--	---

### **An Important Message about Temperatures**

Your generator is designed and rated for continuous operation at ambient temperatures up to 40 degrees Celsius. When your generator is needed, it may be operated at temperatures ranging from -15 degrees Celsius to 50 degrees Celsius for short periods. If the generator is exposed to temperatures outside this range during storage, it should be brought back within this range before operation.

In any event, the generator must always be operated outdoors, in a well-ventilated area and away from doors, windows and other vents. When operated above 25 degrees Celsius, there may be a decrease in power.

Maximum wattage and current area subject to and limited by such factors as fuel BTU content, ambient temperatures, altitude, engine condition etc. Maximum power decreases about 3.5% for each 1000 feet above sea level, and will also decrease about 1% for each -12.2 degrees Celsius above 16 degrees Celsius ambient temperature.

## POWER LOADING MANAGEMENT

 <b>WARNING</b>	NEVER exceed the rated wattage capacity of your generator. OVERLOADING may cause SERIOUS DAMAGE to the generator and attached electrical devices and may result in fire.
--	--

Your generator **MUST** be sized properly to provide both the running and starting (surge) wattage of the devices you will be powering. Before using your generator, determine the running and starting wattage requirements of all the electrical devices you will be powering simultaneously.

Following below are 4 simple steps and an example on the right:

- Step 1 Determine the tools and appliances you want to power at the same time.
- Step 2 List the start up and running power usage (watts) for each product.
- Step 3 Add the total power usage and add 10% as a safety net.
- Step 4 Choose a generator with a rated maximum power that equals or exceeds your total requirements. In this case, a generator with a rated power of at least 3108W and a maximum power output greater than 7233W would be required.

Use the following formula to convert voltage and amperage to watts: Volts x Amps = Watts

To prolong the life of your generator and attached devices, follow these steps to add electrical load:

1. Start the generator without any electrical load attached.
2. Allow the generator to run for several minutes to stabilize.
3. Plug in and turn on the first item. It is advised to attach

- the item that requires the largest load first.
4. Allow the generator to stabilize.
  5. Plug in and turn on the next item.
  6. Allow the generator to stabilize.
  7. Repeat 5 and 6 for each additional item.

## CONNECTING ELECTRICAL LOADS

1. Let the engine stabilize and warm up for a few minutes after starting.
2. Prior to powering tools and equipment, make sure the generator's rate voltage and amperage capacity (120V AC @ 7 AMPs, 12V DC @ 8 AMPs) is adequate to supply all electrical loads that the unit will power. If powering exceeds the generator's capacity, it may be necessary to group one or more of the tools and/or equipment for connection to a separate generator.
3. Once the generator is running, simply connect the power cords of 120V AC dual outlets and/or the power cord of a 12V DC tool to the DC terminals.
4. DO NOT connect 3-phase loads to the generator.
5. DO NOT connect 50Hz loads to the generator.
6. DO NOT overload the generator.

## STARTING POWER CONSUMPTION

Electronic appliances and brushed motors generally will not draw more than running watts at start up.

Induction motors in equipment like air conditioners, welders, water pumps and compressors can draw 2 to 5 times their running power to start.

Please consult your equipment's rating label, manual or the manufacturer to confirm specific requirements.



**Note:** The DC terminals may be used for charging 12 volt automotive type batteries only.

If only the running wattage is given on the nameplate for a device with an electric motor, the starting wattage can approximate to be three to five times the running wattage.

Estimates for the running wattage requirements for common devices are listed below.

Guidance for starting wattages is provided in the table's footnotes.

To size your generator correctly you need to use watts- here are some useful calculations:

**WATTS=VOLTS X AMPS.**

**EXAMPLE:240 VOLTS X 5 AMPS =1200 WATTS**

**WARNING**

NEVER exceed the rated wattage capacity of your generator. **OVERLOADING** may cause **SERIOUS DAMAGE** to the generator and attached electrical devices and may result in fire.

Your generator **MUST BE SIZED PROPERLY** to provide both the running and starting (surge) wattage of the devices you will be powering. Before using your generator, determine the running and starting wattage requirements of all the electrical devices you will be powering simultaneously. Following below 4 simple steps and example on the right:

- Step 1. Determine the tools and appliances you want to power at the same time  
 Step 2. List the start up and running power usage (Watts) for each product  
 Step 3. Add the total power usage and add 10% as a safety net  
 Step 4. Choose a generator with a rated and maximum power that equals or exceeds your totals  
 In this case a generator with a rated power of at least 3108W and a maximum power output greater than 7233W would be required.

PRODUCT	RUNNING	START UP
1HP Water Pump	750W	4500W
Lights	75W	75W
Table saw	2000W	2000W
<b>Total</b>	<b>2825W</b>	<b>6575W</b>
+10%	<b>3108W</b>	<b>7233W</b>

**STARTING POWER CONSUMPTION**

Electronic appliances and brushed motors generally will not draw more than running Watts at start up. Induction motors in equipment like air conditioners, welders, water pumps and compressors can draw 2 to 5 times their running power to start. Please consult your equipment's rating label, manual or the manufacturer to confirm specific requirement. If only the running wattage is given on the nameplate for a device with an electric motor, the starting wattage can be approximated to be three to five times the running wattage. Estimates for the running wattage requirements for common devices are listed in the table below. Guidance for starting wattages is provided in the table's footnotes.

To size your generator correctly you need to use Watts - here are some useful calculations: Watts = Volts x Amps Example 240 Volts x 5 Amps = 1200 Watts

DEVICE	RUNNING WATTS	DEVICE	RUNNING WATTS
Air conditioner (12,000 BTU)	1700 (a,b)	Jet pump	800 (a)
Battery charger (20 Amp)	500	Lawn mower	1200
Belt sander (3")	1000	Light bulb (100 Watt)	100
Chain saw	1200	Microwave oven	700
Circular saw(6½")	2000 (a,b)	Milk cooler	1100 (a)
Coffee maker	1800 (a,b)	Oil burner on furnace	300
Compressor (1 HP)	1400 (a,b)	Oil-red space heater (140,000 Btu)	400
Compressor (3/4 HP)	1800 (a)	Oil-red space heater (85,000 Btu)	225
Compressor (1/2 HP)	1400 (a)	Oil-red space heater (30,000 Btu)	150
Curling iron	700	Oven	4500
Dishwasher	1200	Paint sprayer, Airless (1/3 HP)	600 (a)
Edge trimmer	500	Paint sprayer, Airless (handheld)	150
Electric nail gun	1200	Radio	200
Electric range (1 element)	1500	Refrigerator	600 (b)
Electric skillet	1250	Slow cooker	200
Furnace fan (1/3 HP)	1200 (a)	Submersible pump (1-1/2 HP)	2800 (a)
Freezer	800 (b)	Submersible pump (1 HP)	2000 (a)
Hair dryer	1200	Submersible pump (1/2 HP)	1500 (a)
Hand drill (1")	1100	Sump pump	600 (a)
Hand drill (3/8")	500	Television	500
Hedge trimmer	450	Toaster	1000
Home computer	150	Vacuum cleaner	250
Kettle	2400	Water heater	3000

(a) Hard-starting motors require 3-5 times the rated running watts (b) For extremely hard to start loads such as air conditioners and air compressors, consult the equipment dealer to determine max wattage



## CONTROLS AND FEATURES

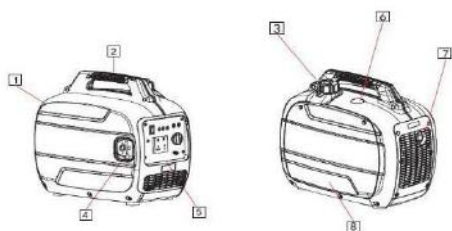

- |    |                 |    |                   |
|----|-----------------|----|-------------------|
| 1  | Muffler         | 5. | Control Panel     |
| 2. | Carrying Handle | 6. | Fuel Gauge        |
| 3. | Vented Gas Cap  | 7. | Exhaust and Spark |
| 4. | Recoil Starter  | 8. | Oil Filler Cap    |

## CONTROL PANEL

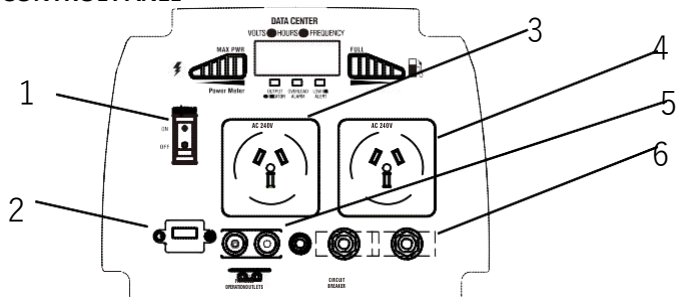

1. Economy Throttle (black)
2. 5V DC USB
3. AC Output
4. AC Output
5. Parallel Output
6. Circuit Breaker

## CONTROL FUNCTIONS

### Eco Throttle:

When the throttle switch is in the ON position, the throttle controls the engine speed according to the connected electrical load. The results are better fuel consumption and less noise. when the switch is in the OFF position, the engine runs at 4.500 rpm regardless of the electrical load.

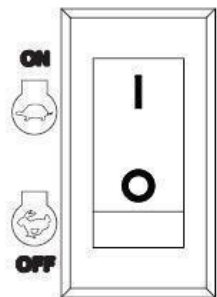

**ECONOMY THROTTLE**



**Note:** The throttle must be OFF when using electrical devices that require a large starting current, such as a compressor, pump or refrigerator.

### LED Indicators

The LED indicators assist in communicating status and functions of the unit.

#### Output Indicator (Green)

The Output Indicator comes on when the engine starts and produces power.

#### Overload Alarm (Red)

The overload alarm comes on when a connected device requires more power than the generator is able to product. The output

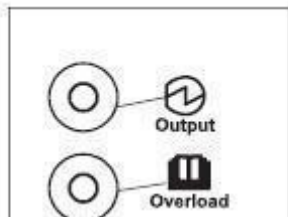

indicator (green) will go off and the overload alarm (red) will stay on, but the engine will continue to run.

### **CAUTION: DO NOT OVERLOAD THE GENERATOR**

#### **Low Oil Alarm**

When the engine oil falls below the required level, the low oil alarm will come on and the engine will stop automatically. The engine will not restart until oil is added to the unit to bring it up to the appropriate level.

### **TO RESET THE GENERATOR**

1. Turn off any connected electric devices and stop the engine.
2. Reduce the total wattage of connected electric devices within the rated output.
3. Use in proper ventilated areas. Maintain at least 3ft of clearance on all sides for adequate cooling.
4. After checking, restart the engine. (refer to part 3.4 in this manual for how to start).

**Note:** The overload alarm may come on for a few seconds when first using electrical devices that require a large starting current, such as a compressor, pump, or refrigerator. This is normal and not a malfunction.



**Note:** The overload alarm may come on for a few seconds when first using electrical devices that require a large starting current such as a compressor, pump, or refrigerator. This is normal and not a malfunction.



**Note:** When starting the unit, if the low oil alarm light flickers and the engine will not start, you will need to add engine oil before attempting to restart the engine.



**Note:** Generator should only be operated on a level



surface. DO NOT operate the generator on loose ground or obvious\ inclines. The low oil shutdown feature may be prematurely activated in these

cases, causing the engine to not start.

### 12V 8A DC

The 12V 8A DC output is for battery recharging. Follow instructions in The owner's manual for the battery for charging procedures.

### 8A DC Circuit Breaker

The 8A DC circuit breaker turns off automatically if the current exceeds 8A. If the circuit breaker turns OFF, you will need to push it in to turn ON again.

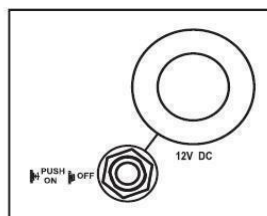

### Parallel Output

Two generators can be connected to increase output. Put parallel wire into the socket first, then start the two greater wattage as the normal process. Note: Put the connection wire into the right sockets (please refer to 4.4 for how to connect properly).

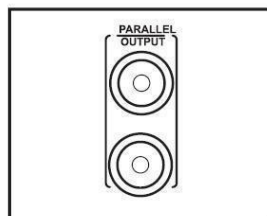

### Multi-Switch

The multi-switch control fuel valve, choke and engine switch. When starting the generator, rotate the multi-switch counter clockwise from OFF to START position, then pull recoil cord quickly to start. After started, rotate the switch to RUN position. Note: To shut off generator, rotate multi-switch clockwise to OFF position and hold until generator turns off.

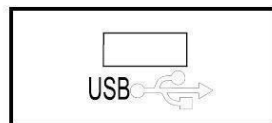
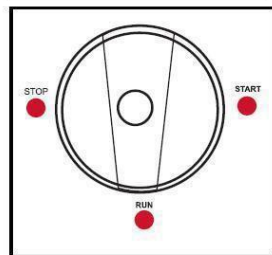

## 240V AC Outlet

The outlet is used to power 240V single phase 50Hz loads requiring up to 2500W continuous power.

240V AC may be used to supply electrical power when parallel connected. Note: When two generators are connected in parallel for greater wattage loads.

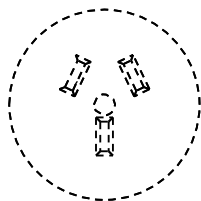

## GROUND TERMINAL

Properly ground the generator to prevent electrical shock.

Connect the ground terminal of generator to the ground electrode buried in the ground.

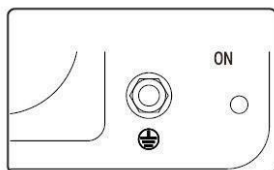

## PRE-OPERATION CHECKS

### UNPACKING THE GENERATOR:

- Remove the generator from its packaging.
- Inspect the generator to ensure that no damage has occurred in shipping or handling. If the unit appears to be damaged, DO NOT add fuel or attempt to start the generator.



**WARNING!**  
**PACKAGING IS FLAMMABLE!**  
**DO NOT ATTEMPT TO ADD FUEL TO THIS UNIT**  
**BEFORE REMOVING IT FROM PACKAGING.**

### Check to ensure that you have received the following items:

1. Generator
2. 12V charging cables
3. Parallel output cable
4. Oil funnel

### ADDING THE ENGINE OIL:

The generator has been shipped without engine oil. DO NOT add fuel or start the engine before adding engine oil.

In order to add the motor oil, you will need to remove the side panel from the unit (figure 1).

Using a #2 Phillips-head screwdriver, remove screws 1 and 2 (seen in figure 1) and lift up and away to remove the side panel.

Replace oil filler cap and secure side panel with screws.

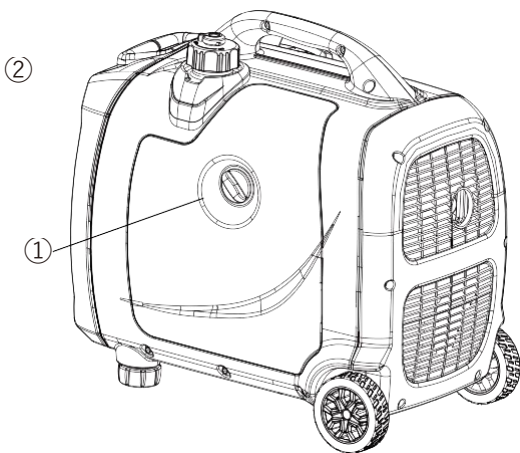

**Figure 1**

Place the generator on a level surface. DO NOT tilt the generator while adding oil. It can cause you to overfill the oil and/or cause the oil to leak into areas in which it is not intended. Remove the oil filler cap (1) as seen in figure 2.

Using the funnel provided, fill with 0.42 litres of SAE 10W-30 or 10W-40, provided (see figure 3). See figure 4 for proper oil level (1).

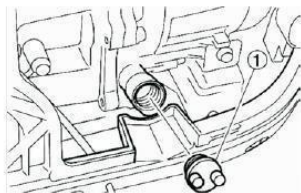

**Figure 2**

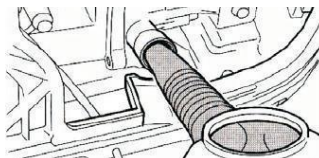

**Figure 3**



## RECOMMENDED ENGINE OIL

SAE 15W-40 is recommended for general all-temperature use. If single viscosity oil is used, select the appropriate viscosity for the average temperature in your area.

Single grade	5W						
	10W						
		20W					
			#20				
				#30			
					#40		
Multigrade	10W-30						
	10W-40						
Ambient temperature	-20	-10	0	10	20	30	40°C
	-4	14	32	50	68	86	104°F

Engine oil quantity:

0.4L (0.42 US qt , 0.35 Imp qt)

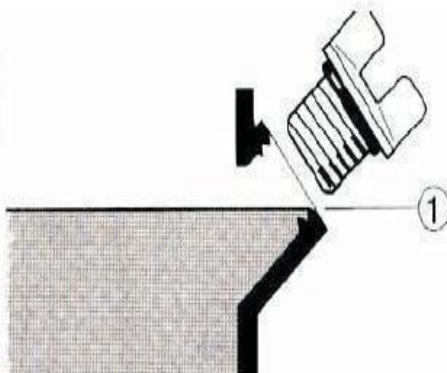

Figure 4

## ADDING FUEL



**Note:**

*For safety reasons, once fuel has been added to this unit it cannot be returned to the place of purchase.*

Do not overfill the tank, otherwise it may overflow when the fuel warms up and expands.

1. Use clean, fresh, regular unleaded petrol with a minimum octane rating of 85.
2. DO NOT mix oil with fuel.
3. Clean area around the fuel cap.
4. Remove the fuel cap.
5. Be sure that the fuel strainer is in place.
6. Slowly add fuel to the tank.
7. DO NOT exceed the red marker position of the fuel filter.
8. Screw on the fuel cap and wipe away any spilled fuel.

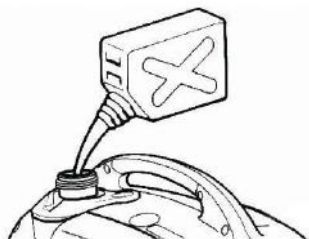

**Note:** Use only unleaded petrol.

The use of leaded petrol will cause severe damage to the internal engine parts.

After filling with fuel, make sure the fuel tank cap is tightened securely.

## STARTING THE ENGINE

Operate the engine in a well-ventilated area. **DO NOT** connect electrical devices to the outlets on the generator before starting the engine.

1. Turn the economy throttle switch **OFF**.  
You may turn the economy throttle switch to **ON** once the engine is started and a steady idle is achieved (below 0degC {32degF}/5 mins, below 5degC{41degF}/3mins)

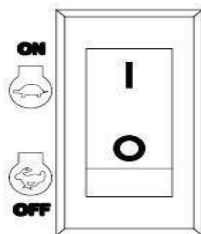

2. While holding the fuel tank cap so that it will not move, turn the air vent knob to **ON**.

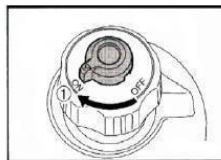

3. Turn the multi-switch to the **START** position.

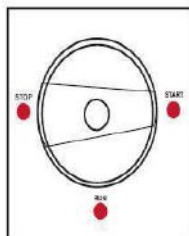

4. Grasp the carrying handle firmly to prevent the generator from falling over when pulling the recoil starter.

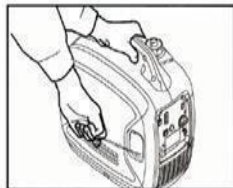

5. Pull slowly on the recoil starter until its engaged and then pull it briskly.
6. After the engine starts, warm up the engine until the engine does not stop when the choke knob is returned to the original position.

 <b>WARNING</b>	<p>A running engine is hot enough to ignite fuel. Never add fuel or remove gas cap if engine is running or still hot. Let cool at least 2 minutes. Check engine oil level each time you refuel. Change oil after the first 20 operating hours and at least every 50 operating hours thereafter.</p> <p>Never open fuel cap while engine is running. Hot fuel can spray over face and body. Hearing can be damaged from prolonged, close-range exposure to the type of noise produced by this generator. The use of ear plugs or other hearing protection device is recommended for a person working within 4-6 metres of the running generator.</p> <p>Loose or dangling apparel can become entangled in moving parts. Metal jewellery can conduct electricity. Never wear jewellery or loose-fitting clothing when operating the generator.</p>
--	--

## ENGINESPEED

Engine speed has been factory set to provide safe operation. Tampering with the engine speed adjustment could result in the overheating of attachments and could cause a fire.

 <b>WARNING</b>	The generator must be run at the correct speed in order to produce the proper electrical voltage and frequency. Failure to do so could result in damage to equipment powered by the generator and possible injury to the individual.
---	--

You will want to be careful when connecting loads so as to not overload the generator, especially if you are powering devices with motors that require a higher starting power load.

Instructions are provided below for connecting loads when you are using the generator as a portable power source.

 <b>WARNING</b>	Do not overload generator. Make sure that combined starting and running loads do not exceed rated capacity of generator. Overloading the generator can cause damage to the generator and attached electrical devices and may result in fire.
---	--

## 240V AC CONNECTION

Connect electrical loads one at a time according to the following instructions:

1. Allow engine to reach operating speed by allowing it to warm up for approximately 5 minutes before connecting electrical devices.
2. Check the devices to be connected are turned OFF before connecting them to the AC outlets.
3. After the engine is warmed up, begin by connecting the items that require the highest wattage first.

### The recommended sequence is as follows:



1. Connect items with motors such as refrigerators, freezers, air conditions or small hand tools, one at a time.
2. Let each motor stabilize before connecting the next device.
3. Connect any lights you are planning on powering.
4. Connect voltage sensitive equipment such as electronics via surge protectors. Plug devices such as TV's, computers and microwaves into voltage surge protectors, then plug the surge protector into the generator.

## 12V DC CONNECTION

The generator is fitted with a socket outlet specifically for connection to a lead acid battery for charging. The output voltage is 12V with maximum output current of 8.3A. The generator will charge lead acid batteries of various sizes from small to large.

DO NOT attempt to charge Nicad, Nickel metal hybrid, or lithium type batteries. ONLY use the provided charger cable. Read the following section for details.

## CHARGING A BATTERY

 <b>WARNING</b>	It's suggested to wear protective clothing, gloves and eye protection when handling and working with lead acid batteries. For operators with pacemakers or similar medical devices and conditions, it is recommended not to attempt the following procedure.  DO NOT attempt to charge a lead acid battery in confined areas. Ensure the charging process takes place in an area where there is fresh air circulating.
 <b>WARNING</b>	DO NOT leave battery charging unattended. Charging battery for a long period of time can damage the battery once the battery is full.  Over-charging or over-heating can damage the battery, the water and acid solution can boil and leak out of the battery.

- Start the engine first and allow to reach idle status before connecting the generator to the battery. Battery charging is performed using the 12V DC outlet only.
- Be sure the throttle switch is turned OFF while charging the batteries.
- Be sure to connect the red battery charger lead to the positive (+) battery terminal and connect the black lead to the negative (-) battery terminal. DO NOT reverse these positions.
- Connect the battery charger leads to the battery terminals securely so that they do not disconnect due to engine vibration or other disturbances.

Change the battery by following the instructions in the owner's manual for the battery

The DC circuit breaker will turn OFF automatically if the current exceeds rate output.

To restart charging the battery, turn the DC protector by pressing the button to ON.

Refer to the owner's manual for the battery to determine charging times.



**Note:** *Never start or stop the generator with electrical devices plugged in or turned on.*

<b>CAUTION</b>	Exceeding the rated capacity of your generator can result in serious damage to your generator and connected apparatus.
----------------	--

- The DC circuit has a circuit breaker to protect the generator from overloading.
- If the circuit breaker trips, unplug all electrical apparatus from the generator.
- Let the overload cut out switch cool down and remove the load from the DC circuit.
- Press the DC reset button.
- When re-connecting the DC load, reduce the load which previously overloaded the generator.

**Note:**

Some batteries, depending on the size, battery condition or level of charge may exceed the max current output from the generator and trip the overload DC circuit breaker.

## STOPPING THE ENGINE

Stopping the engine whilst in the “generator” function:

- Disconnect the load from the AC receptacle
- Turn the engine switch to the “OFF” position
- Turn the fuel cock off

Before stopping the engine, turn off and disconnect electronic devices attached to the generator.

1. Turn the multi-switch to the OFF position.

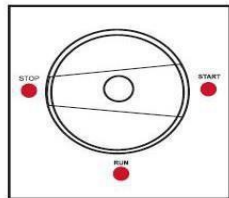

2. While holding the fuel tank cap so that it will not move, turn the air vent knob to OFF.

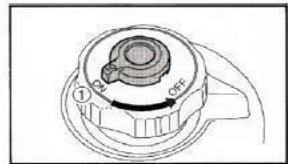

Ensure the generator is in a well-ventilated area as the unit will remain hot even after switching it off.

 <b>WARNING</b>	Fuel and its vapours are extremely flammable and explosive which could cause burns, fire or explosion resulting in death, serious injury and/or property damage. <b>DO NOT</b> stop engine by moving choke control to “Start” position.
---	---

## DURING AN EMERGENCY

If there is an emergency and the generator must be stopped quickly, push the engine control switch to the OFF position immediately.



## **CARBON BUILD UP**

Running the generator at low loads for extended periods can lead to carbon build-up on the spark plug which may subsequently require cleaning.

Carbon build-up can be a problem on generators as the loading on the motor can vary considerably. If the generator has been used for less than 50% of rate load, there is a chance of carbon build-up developing.

Carbon build up in the motor can be reduced by operating the generator at approximately 75% of rated load for 25% of the time the generator is used.

For instance, if the generator is used for 4 hours on low wattage, run the generator for 1 hour at around 75% of rating.

If the generator is being used for solely charging a battery, its recommended to run the 240V at around 500W for the generators up to 2000W if the charging cycle will be run for many hours.

When charging is complete, try and run the generator at around 75% of rate load for an hour or so.

Unleaded fuel without ethanol generally gives the best results.

# TROUBLESHOOTING AND SPECIFICATIONS

## TROUBLESHOOTING

### GENERATOR TROUBLE SHOOTING GUIDE

First check below common start up issues:

Does the unit have fuel in it? Is the engine oil filled up to the threads?

Have you changed/cleaned spark plug?

If the above checklist has been conducted, please refer to the points below:

Problem	Possible Cause	Suggested Correction
Engine will not start	Low on fuel or oil content	A fuel or oil
	Engine On/Off switch in "Off" position	Turn the engine switch to "On" position
	Faulty spark plug	Replace or clean spark plug
	Choke lever in wrong position	Adjust choke lever
	Fuel shut-off valve in closed position	Open fuel shut-off valve
	Unit loaded during start-up	Remove load from unit
	Spark plug wire loose	Attach wire to spark plug
	Old fuel in carburettor	Open drain screw until fresh fuel runs through
No electrical output	Faulty receptacle	Have service centre replace receptacle
	Overload has been triggered	Remove all appliances. Stop the generator, and restart. Reconnect appliances but with reduced load
	Faulty power cord	Have an electrician replace cord
	Master 240V switch turned off	Check the master 240V switch is ON
Repeated overload	Overload	Reduce load
	Faulty cords or equipment	Check for damaged, bare, or frayed wires on equipment. Replace.
Generator overheating	Generator overloaded	Reduce load
	Insufficient ventilation	Move to adequate supply of fresh air
	Blocked exhaust / spark arrester	Spark arrester and muffler screen should be cleaned regularly.
Generator keeps stopping or is operating rough	Check oil level	Add oil so oil is at the correct level
	Generator not sitting on flat and level surface	Move generator to a level and flat surface
	Motor needs to be cleaned of carbon	Remove, check and clean spark arrester if needed. Remove, clean or replace spark plug
	Fuel not getting through the motor	Check fuel filter, if clogged, replace.
	Blocked exhaust / spark arrester	Spark arrester and muffler screen should be cleaned regularly
No DC output	DC circuit breaker requires resetting	Remove load from generator. Allow the reset to cool and then press reset
	Reset button continues to open when load is applied	Check polarity to battery being charged. Red to positive, black to negative

## Troubleshooting Diagram

AE90515

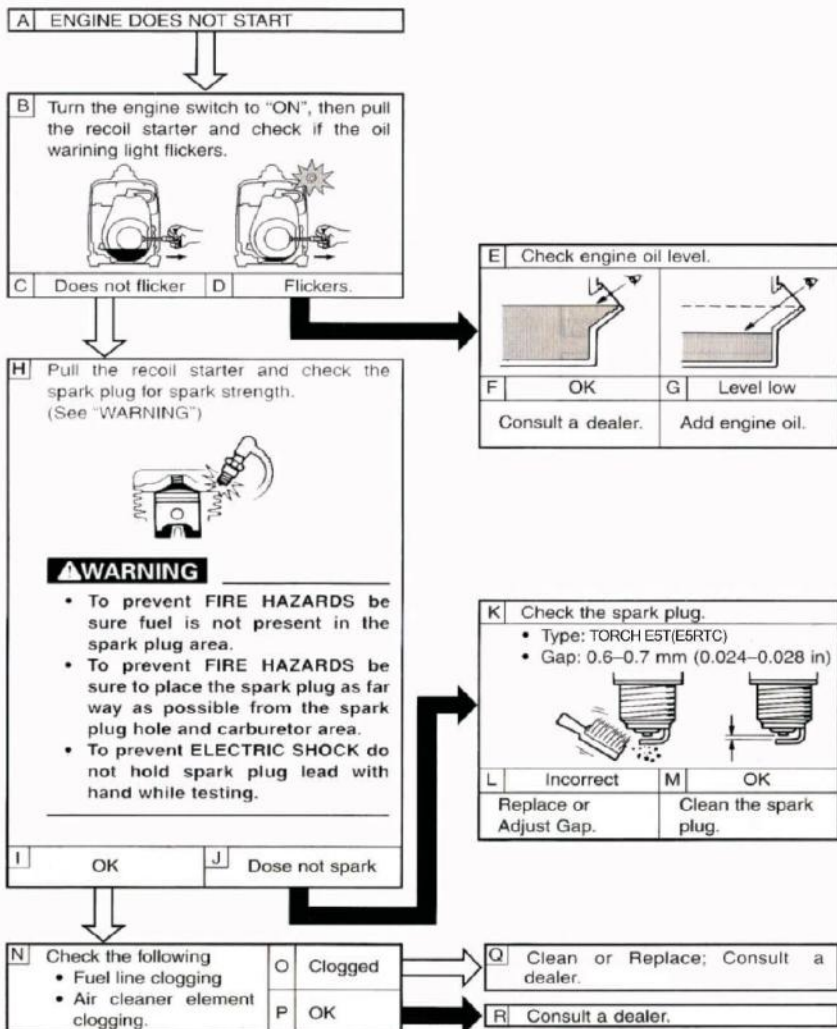

**If the engine will not start:**

Open the fuel cap to check if the engine has sufficient fuel. Open the oil cap dispenser and check if the machine has sufficient oil.

Remove the spark plug and turn the engine switch to the “ON” position to start the engine. Check to see if there is spark coming from the spark plug. Replace the spark plug if necessary.

**If the engine will still not start then contact Maxwatt Power Products for technical assistance. The details are on the back page of this operator’s manual.**

**No Electricity/Voltage at the AC Receptacles:**

Check if the over current protector is in the “ON” position. Turn to the “ON” position if necessary. If there is still no electricity/voltage after this has been done it is possible that there is something wrong or damage has been caused to the AVR (Automatic Voltage Regulator) and or Rotor/Stator.

**Do not attempt to do anything further, contact Maxwatt immediately for assistance.**

**PARALLEL CONNECTION WITHIN 2 GENERATORS:**

Performance allows you to increase the output by connecting two generators together by using the parallel connection wires provided.

**Note:** Make sure generators are powered off and without load when connecting the parallel wires.

Put the parallel connection wire 1 and 2 into the parallel connection sockets 3 and 4.

**Note:**

Grounding wire must be properly connected.

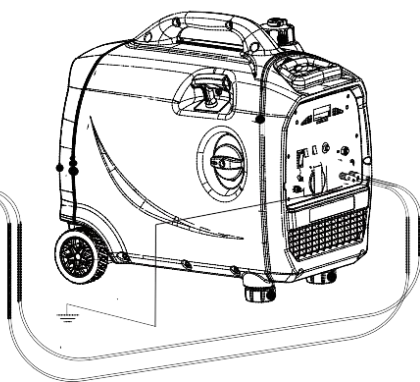
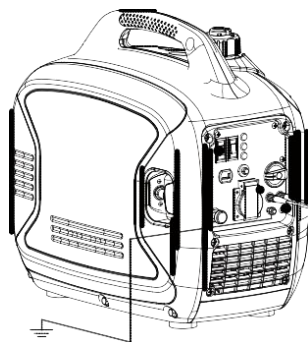
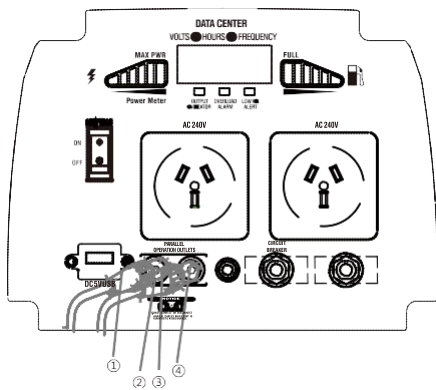
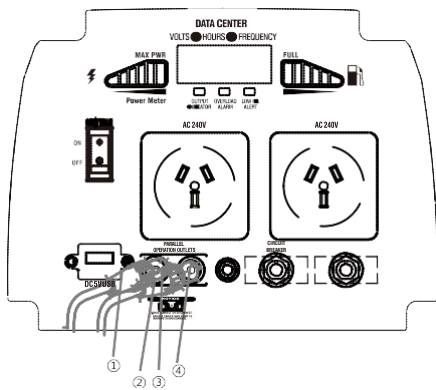

Start 2 sets of inverter generators. The starting operation is as the same as normal process (refer on manual book starting parts).

**Note:** Please make sure the parallel connection wires have been put into the parallel connection sockets properly. If not connected properly, starting the inverter generator could cause damage.

The load plugs can now be plugged into socket 6.

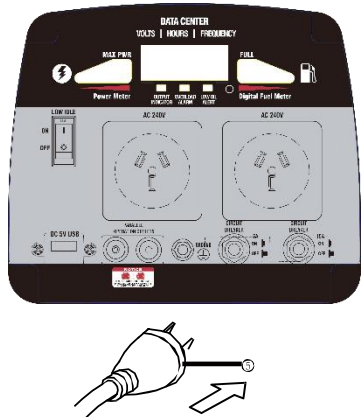
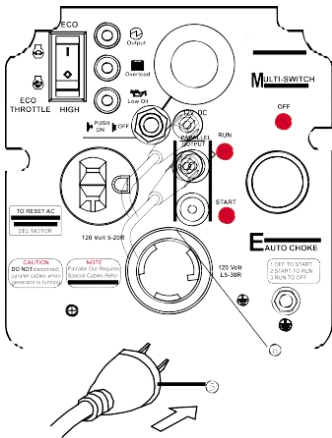

**Warning**

Only 2 sets of the same brand of inverter generators can be parallel connected. Only use the same brand parallel connecting wire.

Make sure to connect the correct parallel wire into the correct socket. Connect the parallel wires when the generator is off. Parallel wires are not necessary when only one generator is being used. Read the manual carefully before operation.

## MAINTENANCE

For all your service, maintenance and warranty queries, please contact Maxwatt Power Products. Please refer to the back page for all contact details.

### DAILY INSPECTION:

Before starting the generator, please check the following service items. These basic inspections can be carried out by a “layman”.

1. Sufficient fuel.
2. Excessive Vibration.
3. Sufficient clean engine oil.
4. Leaking fuel or oil.
5. Safe surroundings.

Periodic inspection, adjustment and lubrication will keep your generator in the safest and most efficient condition possible.

Initial replacement of the engine oil is after one month or 20 hours of operation.

### SPARK PLUG MAINTENANCE

The spark plug is an important engine component and should be checked periodically.

3.
  - Remove the screws (1) and then remove the cover (2).
  - Remove the spark plug cap (3) and access cap (4).
  - Insert the tool (5) through the hole in the outside cover.
  - Insert the handlebar (6) into the tool (5) and turn it counter clockwise to remove the spark plug.
  - Check for discolouration.
  - The carbon porcelain insulator around the centre electrode of spark plug should be a medium-to-light tan colour.
  - Check the spark plug type and gap.

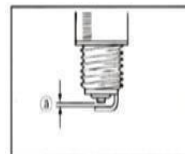
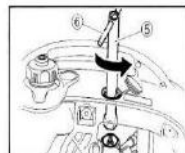
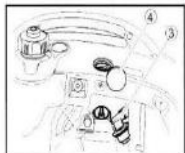
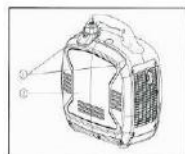



- The spark plug gap should be measured with a wire
- Thickness gauge and, if necessary, adjusted to specification.
- Install spark plug, spark plug cap, cover and screws.

**Spark Plug Type:**

TORCH E5T(E5RTC)

**Spark Plug Gap:**

0.6-0.7 mm (0.024-0.028 in)

**Spark Plug Torque:**

20.0 N·m (2.0kgf·m, 14.8 lbf·ft)

## ENGINE OIL REPLACEMENT

Initial replacement of the engine oil is after one month or 20 hours of operation.

Place the generator on a level surface and warm up the engine for several minutes. Then stop the engine and turn the fuel petcock knob to OFF and the fuel tank cap air vent knob to OFF. Remove the screws (1) and then remove the cover (2).

Remove the oil filler cap. Place an oil pan under the engine. Tilt the generator to drain the oil completely.

Return the generator to a level surface.

**NOTE:** DO NOT tilt the generator when adding engine oil. This could result in overfilling and damage to the engine.

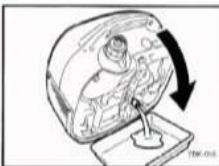
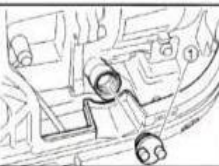
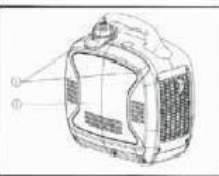
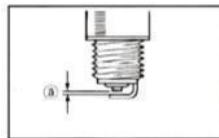
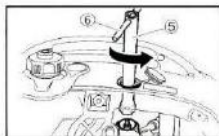
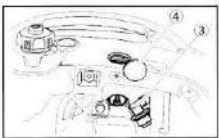
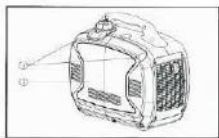

Add engine oil to the upper level as seen in the diagram (1).

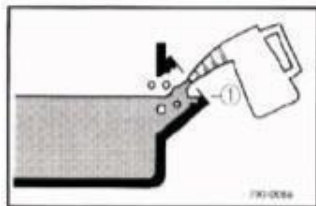

### Recommended engine oil:

YAMALUBE 4 (10W-40), SAE 10w-30 OR 10W-40

SAE#30

SAE#20

SAE10w

### Recommended engine oil grade

API Service SE type or higher.

### Engine oil quantity: 0.4L

Install oil filler cap, cover and screws.

## AIR FILTER MAINTENANCE

Should be performed every 6 months or 100 hrs. The air filter may need to be cleaned more frequently when using in unusually wet or dusty areas.

- Remove the screws (1) and then
- Remove the cover (2).
- Remove the screws (1) and then
- Remove the air filter case cover (2).
- Remove the foam element (1).
- Wash the foam element in solvent and dry it.
- Oil the foam element and squeeze out excess oil.
- The foam element should be wet but not dripping.

**NOTE:** DO NOT wring out the foam element when squeezing it. This could cause it to tear.

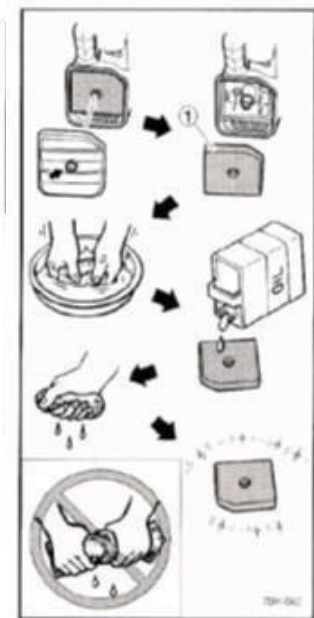

- Insert the foam element into the air filter case. Be sure the foam Element Sealing surface matches the air filter so that there is no air leak.

**NOTE:** Never operate the engine without foam element.

- Install air filter case cover, cover and screws.

### MUFFLER SCREEN AND SPARK ARRESTOR MAINTENANCE

Should be performed every 6 months or 100 hours. The air filter may need to be cleaned more frequently when using in unusually wet or dusty areas.

- Remove the screws (1) and then remove the cover (2).
- Loosen the bolt (1) and then remove the muffler cap (2), the muffler screen (3) and spark arrester (4).
- Remove the carbon deposits on the muffler screen and spark arrester using a wire brush. Use wire brush lightly to avoid damaging the muffler screen or spark arrester.
- Check the muffler screen and spark arrester, replace them if damaged.
- Install the spark arrester.
- Install the muffler cap.
- Install the cover and tighten the screws.

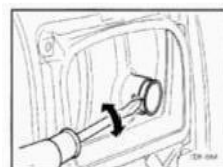
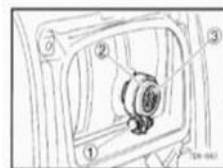
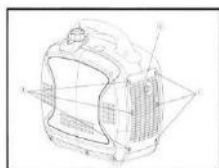

## FUEL FILTER MAINTENANCE

Should be performed every 12 months or 300 hrs.

1. Remove the fuel tank cap and filter (1).
2. Clean the filter with gasoline.
3. If damaged, replace it.
4. Wipe the filter and install it.
5. Install the fuel tank cap.

### WARNING:

Petrol is flammable. **DO NOT** perform this maintenance while smoking or near an open flame.

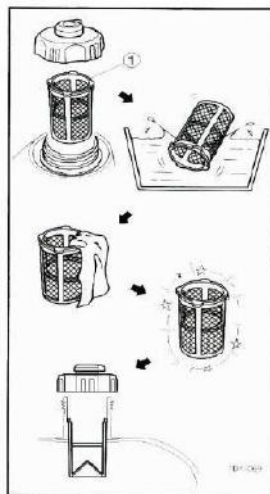

Normal maintenance such as spark plugs, battery, air filters, adjustments, fuel system, cleaning and obstruction due to build up, is not covered by the warranty.

# MAINTENANCE SCHEDULE



## WARNING

To prevent accidental starting that could cause serious personal injury, always switch off the engine and disconnect the spark plug wire/lead before carrying out maintenance work.

### PERIODIC MAINTENANCE

Item	Remarks	Pre-operation check (daily)	Initial 1 month or 20 Hrs	Every 3 months or 50 Hrs	Every 6 months or 100 Hrs	Every 12 months or 300 Hrs
Spark Plug	Check condition, adjust gap and clean. Replace if necessary.				*	*
Engine Oil	Check oil level.	*				
	Replace.		*		*	
Air Filter	Clean.	*		*		
	Replace.					*
Fuel Filter	Clean fuel drain filter. Replace if necessary.				*	
Fuel Inline	Check fuel hose for crack or damage. Replace if necessary.	*				
Exhaust System	Check for spark arrester. Retighten or replace if necessary.		*			
	Check muffler screen. Clean/replace if necessary.		*			
Carburettor	Check choke operation.	*				
Starting System	Check recoil starter operation.	*				
Fittings/ Fasteners	Check all fittings and fasteners, correct if necessary.				*	

## MAINTENANCE LOG

### MAINTENANCE LOG

Your Maxwatt generator is protected by a 2-year limited warranty (3 month on battery) that covers the product for normal use. The warranty statement is found on the back of this manual. You must understand that negligence or misuse is not covered in the warranty and failure to properly maintain and service the engine, can void your warranty. Please keep records of your service, maintenance and repair history to ensure the product has all the required information to action your warranty, if so required.

No.	Service Date	Hours of Operation	Action	Comments
	<b>Please note the date and store of purchase. Keep your receipt.</b>			
	<b>Date of Purchase:</b>			
	<b>Maxwatt batch number or serial number:</b>			
0				
1				
2				
3				
4				
5				
6				
7				
8				
9				
10				
11				
12				
13				
14				

Normal maintenance such as spark plugs, battery, air filters, adjustments, fuel system cleaning and obstruction due to build up is not covered by the warranty.

## **STORAGE**

When you are finished using the generator, you must:

- Disconnect all loads
- Shut off fuel supply
- Disconnect spark plug and battery
- Store the generator properly
- Plan on operating the engine regularly unless the generator is prepared for long term storage.

### **DISCONNECT LOADS AND TURN OFF THE FUEL SUPPLY**

When you are finished using the generator, disconnect all loads and turn off fuel supply.

- Make sure all devices that were connected to the generator's outlets have been disconnected.
- Check to be sure line shut-off valve is in OFF position.

### **COOL THE ENGINE BEFORE STORING**

Let engine cool for at least five minutes before storing. A hot engine can be a fire hazard.

### **CHOOSE A STORAGE LOCATION**

Store the generator in a location that is clean, dry, away from sources of heat, open flames, sparks, or pilot lights and is not subject to extreme high or low temperatures. Residual fuel in the tank could ignite even if the generator's fuel tank is empty.

#### **Note:**

Do not store with battery charger always connected.

Batteries that are over-charged can boil dry and produce excessive amounts of hydrogen and explosive gas.

### **PREVENT ACCIDENTAL STARTING- SPARK PLUG**

Remove spark plug(s) in order to ensure the generator cannot be started accidentally in a storage location or by untrained persons.

### **PREVENT ACCIDENTAL STARTING- BATTERY**

To prevent accidental starting, disconnect the battery before storage.

1. Disconnect negative (-) battery terminal first.
2. Disconnect positive (+) battery terminal last.

### **OPERATE THE ENGINE REGULARLY**

The generator should be operated regularly to maintain the condition of internal parts. At least every four weeks, start the engine and let it run for 10 to 15 minutes with a small load plugged in such as a lamp or fan.

Monthly operation of the generator will dry out any moisture that has accumulated in the windings which if left, can cause corrosion. It will also ensure that the unit is operating properly should it be needed in an emergency.

Before transporting the Generator, please ensure that the fuel cock is in the “**OFF**” position.

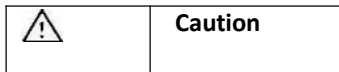

Contact with a hot engine or exhaust system can cause severe burns and or fires, always allow for the engine to cool down prior to transporting and or storing. Always ensure that the Generator is transported and or stored in a flat horizontal position. Tilting of the unit may cause fuel spillage which may result in a fire.



Before storing the generator for an extended period of time, please ensure that the area of storage is free from excessive dust and humidity.

Please follow the table below:

Long term storage of your generator will require some preventative procedures to guard against deterioration.

### 1. Drain the fuel

Remove the fuel tank cap. Extract the Fuel tank into an approved gasoline container using a commercially available hand siphon. Then install the fuel tank cap.



**WARNING:** Gasoline is flammable! DO NOT perform this maintenance while smoking or near an open flame.

1. Immediately wipe off spilled fuel with a clean, dry, soft cloth since fuel may deteriorate painted surfaces or plastic parts.

2. Start the engine and let it run until it stops. Duration of the running engine depends on the amount of fuel left in the tank. Remove the screws (1) and then remove the cover (2).

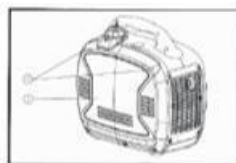

3. Drain the fuel from the carburetor by loosening the drain screw (3) on the carburetor float chamber tighten the drain screw.

4. Remove the dipstick and drain the engine oil. Then tighten the dipstick.
6. Install the cover and tighten the screws.
7. Turn the fuel tank cap air vent knob to OFF.
8. Store the generator in a dry, well ventilated place, with the cover placed over it.



## Engine

- Perform the following steps to protect the cylinder, piston ring, etc. from corrosion:
- Remove the spark plug, pour about one tablespoon of SAE 10W-30 or 20W-40 motor oil into the spark plug hole and reinstall the spark plug. Recoil starts the engine by turning over several times (with ignition off) to coat the cylinder walls with oil.
- Pull the recoil starter until you feel compression. Then stop pulling (this prevents the cylinder and valves from rusting)
- Clean exterior of the generator and apply a rust inhibitor.
- Store the generator in a dry, well-ventilated place, with the cover placed over it.
- The generator must remain in a vertical position when stored, carried or operated.

## REMOVAL FROM STORAGE

Follow the normal procedures for pre-operation checks and starting. Use only fresh fuel to refill the tank, if necessary, rather than re-using the old fuel.

A battery may lose some charge when not in use for prolonged periods of time. If the battery is unable to crank the engine, plug in the 12V charger supplied. See Charging a Battery section for more details.

If oil was inserted into the cylinder prior to storage, the exhaust may smoke for a short while after starting the generator. This is normal and will cease within a minute or so of running time.

## **TRANSPORTING**

If the generator has been used, allow it to cool for at least 15 minutes before loading the generator on the transport vehicle.

A hot engine and exhaust system can burn you and can ignite some material.

Take care not to drop or strike the generator when transporting.

Do not place heavy objects on the generator. When transporting the generator, turn the engine switch and the fuel valve lever OFF and keep the generator level to reduce the possibility of fuel leakage.

# WIRING DIAGRAM

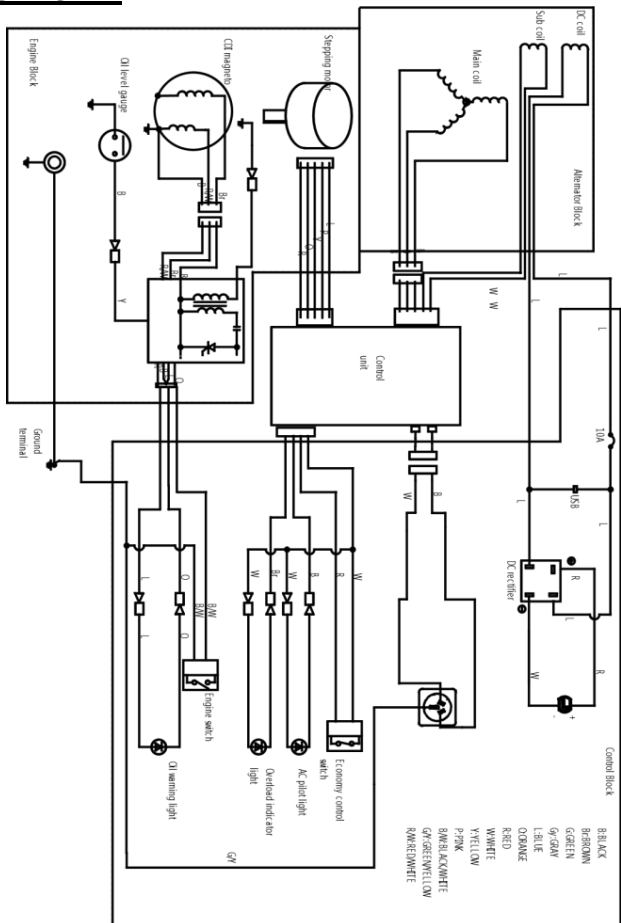

# LABELS

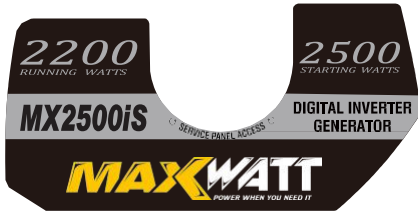
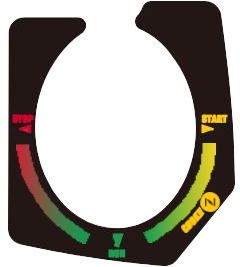

机油贴花 : 59\*66  
32024-01127-00

警告信息贴花 :  
66\*137 32005-  
00826-01

## **WARRANTY INFORMATION**

### **2 YEAR TRADE WARRANTY**

#### **Express Warranty**

Subject to the exclusions set out below, we warrant that this product will be free from defects in materials or workmanship for 24 months from the date of purchase.

The benefits conferred by this warranty are in addition to all rights and remedies which you may be entitled to under the Australian Consumer Law and any other statutory rights you may have under other applicable laws. This warranty does not exclude, restrict, or modify any such rights or remedies.

#### **Warranty Exclusions**

This express warranty does not apply where a defect or other issue with the product is caused by normal wear and tear, misuse or abuse of this product.

#### **Consumer Guarantees**

Our goods come with guarantees that cannot be excluded under the Australian Consumer Law. You are entitled to a replacement or refund for a major failure and for compensation for any other reasonably foreseeable loss or damage.

You are also entitled to have the goods repaired or replaced if the goods fail to be of acceptable quality and the failure does not amount to a major failure.

#### **LIMITED WARRANTY POLICY**

“This is a “walk in” warranty policy and is limited to the range of generators specified herein”. We recommend that you take the generator to the nearest service agent for assistance. Please visit [www.maxwatt.com.au](http://www.maxwatt.com.au) for more information.

#### **To qualify for this warranty:**

“The warranty applies to the first purchaser and each subsequent owner during the applicable warranty time period”.

#### **What the appointed Service Agent will repair or replace under warranty:**

“The appointed Service Agent will repair or replace, at its sole discretion, any part that is proven to be defective in material or workmanship under normal use during the applicable warranty time period. Warranty repairs will be made without any charge for parts and labour. All parts replaced will be considered as part of the original product and the warranty on such parts will expire coincident with the original product warranty”.

## WARRANTY PROCEDURES:

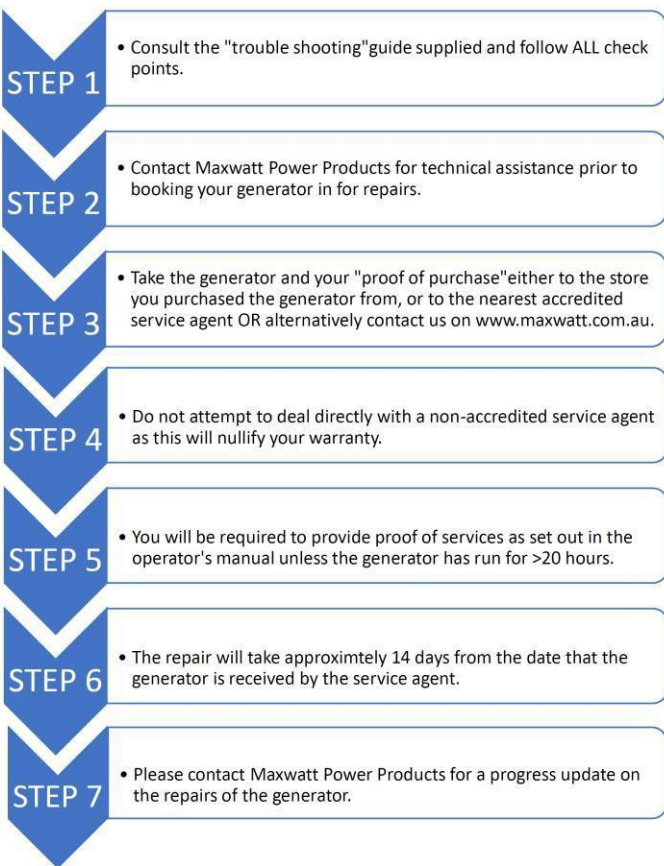

**BELOW IS A LIST OF GENERATORS THAT ARE COVERED UNDER THIS WARRANTY:**

<b>MODELS</b>	<b>WARRANTY PERIOD PRIVATE/RESIDENTIAL</b>	<b>WARRANTY PERIOD COMMERCIAL/RENTAL</b>
<b>MAXWATT ALL MODELS</b>	24 months or 500 running hours which ever come first	24 months or 300 running hours which ever come first

**EXCLUSIONS TO THIS LIMITED WARRANTY INCLUDE:**

- Neglect in the periodic maintenance as specified in the owner's manual.
- Improper repairs or maintenance including any repairs and or maintenance carried out by a non-accredited service agent.
- Operating methods other than those indicated in the owner's manual.
- The use of non-genuine parts and or accessories other than those supplied by an accredited service agent.
- Normal wear and tear including but not limited to the fading of painted or plated surfaces.
- Consumable parts including but not limited to keys, spark plugs, fuel and oil filters, recoil starter ropes, wheels, lubricants, oil grease and fuel.
- Cleaning adjustments and normal periodic maintenance work including but not limited to cleaning of the battery, carburetor, engine oil, fuel tank and injectors.
- Over loading resulting in the damage of the AVR, circuit breaker, stator and rotor.
- Charging and proper maintenance of the battery.
- Correct preparation when using the generator for the first time as set out in the owner's manual.



- Fire damage as a result of but not limited to overloading, incorrect installation, incorrect re-fueling and any other causes as set out in the owner's manual.
- Damage to any electronic and or electrical appliances connected to the generator.

**BELOW IS A TABLE OF PARTS THAT ARE LIMITED BY THIS WARRANTY**

<b>PART</b>	<b>OUT OF BOX FAILURE</b>	<b>&lt; 20 RUNNING HOURS</b>
<b>STATOR</b>	*	
<b>ROTOR</b>	*	
<b>CIRCUIT BREAKER</b>	*	
<b>AVR</b>	*	
<b>IGNITION COIL</b>		*
<b>SPARK PLUG</b>		*
<b>BATTERY</b>		*
<b>WHEELS AND AXLE</b>		*
<b>HANDLES</b>		*
<b>RECOIL STARTER</b>		*

**\*NOTE:**

OUT OF BOX FAILURE REFERS TO A MACHINE THAT HAS RUN FOR < 20 MINUTES.

## **DISCLAIMER OF CONSEQUENTIAL DAMAGE AND LIMITATION OF IMPLIED WARRANTIES**

Maxwatt Power Products disclaims any responsibility for the loss of time or use of the product, transportation, commercial loss or any other incidental or consequential loss or damage. Any implied warranties are limited to the duration of this written limited warranty policy and procedures manual.

## **ONLINE ORDER RETURNS POLICY**

If you believe an item is faulty, you may have rights to a remedy under the Australian Consumer Law. The Australian Consumer Law does recognize that the relevant time period may vary by product (or service) depending on the nature of the goods (or service), the price paid and any representations made about the goods (or service).

Where you believe an item is faulty, it may be necessary for us to send your goods to the manufacturer or their service agent for it to be assessed within a reasonable period of time. If there is a major failure with the item, you may choose a refund, exchange or repair. If the failure is minor, we will repair the item (or, at our discretion, we may replace the item) within a reasonable time.

Where an item is damaged through misuse or abnormal use, the manufacturer cannot provide a refund, exchange or repair. Maxwatt Power Products require satisfactory proof of purchase before providing a remedy under the Australian Consumer Law.

## **DAMAGED IN TRANSIT**

Please do not sign for the delivery of goods that are obviously damaged. If damage is only found upon unpacking, then please contact the store that fulfilled your order as soon as possible. Store contact details can be found on your order confirmation email. They will then arrange for the goods to be collected and a refund or replacement item sent out to you. Alternatively, please take the items to your nearest store where they will be able to help you.

## **NOT AS ADVERTISED / INCORRECT ITEM**

If your order arrives and it's not what you ordered, please contact either the store the order came from or on the online support team at [customercare@maxwatt.com.au](mailto:customercare@maxwatt.com.au).

## **FAULTY PRODUCT**

Please contact the store that fulfilled your order. Store contact details can be found on your order confirmation email. The store will need to assess whether the fault is a major or minor fault and will either arrange for the product to be repaired or replace. Some manufacturers require us to send fault items to them for assessment before we can give you a replacement.

## **CHANGE OF MIND**

Changed your mind? Don't worry. You've got 30 days to get your order back to the store it was sent from and provided its un-used we'll give you a refund minus the costs of any shipping.

## **VALID RECEIPT**

A copy of your in-store purchase receipt or online order confirmation email is required for any return. If returning your product to store, please ensure you take a copy with you.



---

Distributed by: Maxwatt Power Products  
Unit 5, 1440 New Cleveland Road,  
Chandler  
Queensland  
Australia